

Defense Information Systems Agency



Defense Spectrum Organization



**Joint Spectrum Center
Annapolis, Maryland 21402**

Consulting Report

Communications Receiver Performance Degradation Handbook

Document Control No. JSC-CR-10-004

11 August 2010

Prepared for:

**Joint Spectrum Center
2004 Turbot Landing
Annapolis, MD 21402-5064**

Prepared by:



Engineered for life

**ITT Corporation
AES Division
16701 Melford Blvd., Suite 200
Bowie, MD 20715**

This report was prepared by the ITT Corporation under Contract HC1047-07-D-0001 in support of the Defense Information Systems Agency's Joint Spectrum Center in Annapolis, Maryland.

This report has been reviewed by the following ITT personnel:

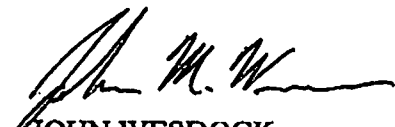

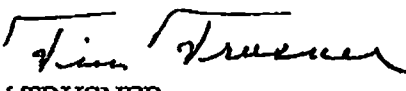
JOHN WESDOCK
Project Manager, ITT

TIM TRUSNER
Department Manager, ITT

DONALD MCLEMORE, Ph.D.
Chief Scientist, ITT

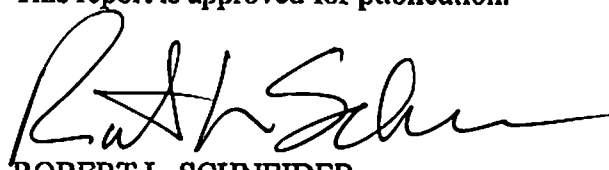
This report is approved for publication.

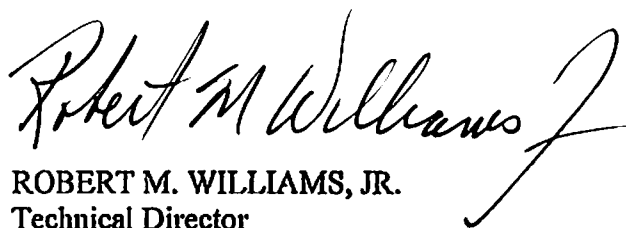
ROBERT L. SCHNEIDER
Chief, RD&A
Joint Spectrum Center

ROBERT M. WILLIAMS, JR.
Technical Director
Defense Spectrum Organization

REPORT DOCUMENTATION PAGE			Form Approved OMB No. 0704-0188		
Public reporting burden for this collection of information is estimated to average 1 hour per response, including the time for reviewing instructions, searching existing data sources, gathering and maintaining the data needed, and completing and reviewing this collection of information. Send comments regarding this burden estimate or any other aspect of this collection of information, including suggestions for reducing this burden to Department of Defense, Washington Headquarters Services, Directorate for Information Operations and Reports (0704-0188), 1215 Jefferson Davis Highway, Suite 1204, Arlington, VA 22202-4302. Respondents should be aware that notwithstanding any other provision of law, no person shall be subject to any penalty for failing to comply with a collection of information if it does not display a currently valid OMB control number. PLEASE DO NOT RETURN YOUR FORM TO THE ABOVE ADDRESS.					
1. REPORT DATE (DD-MM-YYYY) 11-08-2010		2. REPORT TYPE Consulting		3. DATES COVERED (From - To)	
4. TITLE AND SUBTITLE Communications Receiver Performance Degradation Handbook			5a. CONTRACT NUMBER HC1047-07-D-0001		
			5b. GRANT NUMBER		
			5c. PROGRAM ELEMENT NUMBER		
6. AUTHOR(S) Wesdock, John; Patel, Chitra; Bustamante, Eduardo; Michel, Jeremy; Zhang, Yuwen – ITT Corp Wheeler, Dr. Donald; Canzona, Nicholas – Alion Science and Technology			5d. PROJECT NUMBER T1314		
			5e. TASK NUMBER		
			5f. WORK UNIT NUMBER		
7. PERFORMING ORGANIZATION NAME(S) AND ADDRESS(ES) AND ADDRESS(ES) Joint Spectrum Center RD&A Division (JSC/J5) 2004 Turbot Landing Annapolis, MD 21402-5064			8. PERFORMING ORGANIZATION REPORT NUMBER JSC-CR-10-004		
9. SPONSORING / MONITORING AGENCY NAME(S) AND ADDRESS(ES) National Telecommunications and Information Administration 1401 Constitution Ave, NW Washington, DC 20230			10. SPONSOR/MONITOR'S ACRONYM(S) NTIA		
			11. SPONSOR/MONITOR'S REPORT NUMBER(S)		
12. DISTRIBUTION / AVAILABILITY STATEMENT Approved for public release; distribution is unlimited.					
13. SUPPLEMENTARY NOTES					
14. ABSTRACT This handbook provides the radio frequency (RF) analyst with the capability to calculate the effects of noise and interference on RF communications receivers. A receiver is modeled as a sequence of modules. Each module has a transfer function that relates the module outputs to the module inputs. By consecutively analyzing each module in the sequence, the analyst can then relate the receiver outputs (performance) to the receiver inputs (signal characteristics). A wide variety of communications modulation and coding techniques are considered for this handbook including Quadrature Phase Shift Keying (QPSK), Gaussian Minimum Shift Keying (GMSK), Orthogonal Frequency Division Multiplexing (OFDM), Low Density Parity Check Coding (LDPC) and Turbo Product Coding (TPC). Interferers considered include continuous and pulsed narrow and broadband interferers which are on-tune, off-tune and adjacent channel.					
15. SUBJECT TERMS communications receiver, frequency-dependent rejection, FDR, spread spectrum, demodulator, forward error correction, FEC, bit error rate, BER, source decoder, noise, interference, LDPC, TPC, OFDM, GMSK					
16. SECURITY CLASSIFICATION OF:			17. LIMITATION OF ABSTRACT	18. NUMBER OF PAGES	19a. NAME OF RESPONSIBLE PERSON
a. REPORT	b. ABSTRACT	c. THIS PAGE			
U	U	U	SAR	339	Robert M. Williams, Jr
			19b. TELEPHONE NUMBER (include area code) 410-293-9263		

This page intentionally left blank.

EXECUTIVE SUMMARY

In May 2003, President Bush established the Spectrum Policy Initiative to promote the development and implementation of a United States spectrum policy for the 21st Century. In response to the Spectrum Policy Initiative, the Secretary of Commerce established a Federal Government Spectrum Task Force and initiated a series of public meetings to address policies affecting spectrum use by the federal government, state and local governments, and the private sector. The recommendations resulting from these activities were included in two reports released by the Secretary of Commerce in June 2004. In November 2004, the President directed the federal agencies to develop a plan to implement the 24 recommendations contained in the reports. One of the recommendations directed the National Telecommunications and Information Administration (NTIA) to develop a handbook documenting best practices in spectrum engineering that will be recognized by all regulatory authorities in the United States.

The “Best Practices Handbook” (BPH) will bring together a common set of approaches for conducting Electromagnetic Compatibility (EMC) analysis and will develop a common set of Interference Protection Criteria (IPC) for performing technical studies to evaluate potential interference issues with emerging technologies. NTIA recognized that the communications receiver degradation handbooks previously developed by the Joint Spectrum Center (JSC) have proven to be a valuable technical resource in establishing IPC values used in EMC analyses. Therefore, NTIA requested that the Defense Spectrum Organization/JSC expand and enhance the Communications Receiver Performance Degradation Handbook and provide it to NTIA such that it could be incorporated into the BPH.

The Communications Receiver Performance Degradation Handbook (henceforth referred to as the Handbook) provides Radio Frequency (RF) analysts with the capability to calculate the effects of noise and interference on RF communications receivers. This is accomplished by providing the Handbook user with a concise description of communications receiver theory, describing how interference impacts communications systems, presenting a step-by-step interference evaluation method, and providing a catalog of Bit Error Rate (BER) performance data in the presence of various interferers.

The interference evaluation method presented in the Handbook is applicable not only for simple interference scenarios such as Continuous Wave (CW)-like and Additive White Gaussian Noise (AWGN)-like interference but also for complex interference scenarios such as pulsed interference and continuous interference which is not CW-like or AWGN-like. A key feature of the Handbook evaluation method is that it offers the RF analyst a means to quickly assess the potential performance degradation effect of complex interference scenarios without having to perform extensive, complicated analysis or simulation.

The techniques presented in the Handbook are applicable to RF communications systems regardless of the specific frequency band of operation; that is, the techniques are applicable at L-band, S-band, X-band, and so on. Additionally, specific communications system parameters such as data rate and Pseudorandom Noise (PN) chip rate are parameters within the analysis.

The Handbook considers the modulation, coding and interferer types which are relevant in today’s RF environment and in emerging technologies. To the latter, consideration is given to the underlying signal structures of WiFi, Worldwide Interoperability for Microwave Access (WiMax), Wireless Local Area Network (WLAN) and Ultra-Wideband (UWB).

Section 1 provides general background and overview information.

Section 2 describes the general procedures for performing a communications receiver performance analysis. It introduces the fundamental concepts and describes the receiver model.

Section 3 provides a detailed description of the RF/Intermediate Frequency section. It also specifies how interfering signals may be changed by the filters.

Section 4 describes the despreader module in spread spectrum receivers. It specifies how the spread spectrum processing gain can be calculated. It also provides information that can be used to analyze spread spectrum multiple-access systems.

Sections 5 and 6 describe the demodulator module. They provide plots that characterize performance as a function of the input signal-to-interference power ratios. Analog voice and broadcast television receivers are considered in Section 5 and digital receivers are considered in Section 6.

Section 7 describes forward error correction (FEC) decoders, which use redundancy bits to reduce the BER by correcting some of the bit errors introduced by interference and noise. It provides plots of output BER vs. input BER for several types of FEC decoders.

Section 8 describes source decoders, which convert the information bit sequence to the final format at the receiver output. For a digital voice system, this format is an analog voice waveform. Section 8 provides plots that relate output signal quality to the input BER.

Section 9 presents examples that demonstrate how this Handbook can be used to perform a receiver analysis.

Observations can be stated regarding the receiver performance degradation data presented in this Handbook. Observations are described in the following Table.

Summary of Handbook Observations

#	Observation	Examples
1	As the modulation order increases, receiver performance degradation increases for a given amount of interference	<ul style="list-style-type: none"> Compare Figure 6.6-1 to Figure 6.6-2 Compare Figure 6.6-3 to Figure 6.6-4
2	Uncoded communications systems sustain more performance degradation than coded communications systems	<ul style="list-style-type: none"> Compare Figure 6.6-9 to Figure 7.9-4 Compare Figure 6.6-10 to Figure 7.10-5
3	Large block codes are particularly effective at mitigating pulsed interference	<ul style="list-style-type: none"> See Figures 7.5-22, 7.5-23, 7.5-25, 7.5-26, among others
4	Direct sequence spread spectrum systems tend to drive continuous interferers to be AWGN-like at the input to the bit / symbol synchronizer – this is the result of the receiver PN correlation (despreader) operation	<ul style="list-style-type: none"> Not easily discernible in the performance degradation data
5	For a pulsed interference scenario, performance asymptotes are clearly visible and can be predicted via analytical techniques	<ul style="list-style-type: none"> See Figures 6.6-10, 6.8-5, 6.9-3, 6.10-2, 6.12-6, among others

#	Observation	Examples
6	For a pulsed interference scenario, the interference tends to be AWGN-like at the demodulator input when $T_p \ll T_s$ and $T_p \ll \text{PRI}$; T_s is the modulation symbol duration. T_p = pulse on time; PRI = pulse repetition interval.	<ul style="list-style-type: none"> • See Figures 6.6-9, 6.6-16, 6.7-4, 6.7-8, among others
7	For a pulsed interference scenario, the interference tends to be narrowband-like at the demodulator input when $T_p \gg T_s$ and $T_p \ll \text{PRI}$	<ul style="list-style-type: none"> • See Figures 6.6-11, 6.6-18, 6.7-6, 6.7-9, among others
8	Pulse Position Modulation (PPM) is particularly resilient to receiver performance degradation due to interference. This benefit comes at the expense of spectrum efficiency.	<ul style="list-style-type: none"> • Compare Figure 6.6-10 to Figure 6.16-3 • Compare Figure 6.6-11 to Figure 6.16-4
9	While block codes are effective at mitigating interference, performance may be undermined by excessive interference levels which restricts the ability of the codes to estimate channel signal-to-noise ratio – a capability needed to ensure optimal decoding of the codes	<ul style="list-style-type: none"> • Not easily discernible in the performance degradation data

This page intentionally left blank.

TABLE OF CONTENTS

SECTION 1 - INTRODUCTION	1
1.1 BACKGROUND	1
1.2 PURPOSE OF THE HANDBOOK.....	1
1.3 OVERVIEW OF HANDBOOK CONTENTS.....	1
1.4 HOW TO USE THIS HANDBOOK	2
SECTION 2 - ANALYSIS PROCEDURES	3
2.1 RF SYSTEM TYPES	3
2.1.1 Point-to-Point	3
2.1.2 Point-to-Multipoint	3
2.1.3 Multipoint-to-Multipoint.....	4
2.1.4 Mobile	4
2.2 SIGNAL TYPES	4
2.2.1 Noise.....	4
2.2.2 Continuous-Wave Signal	5
2.2.3 Modulated Signal	5
2.2.4 Pulsed Signal	5
2.2.5 Intermittent Signal	5
2.3 LINK BUDGET ANALYSIS.....	6
2.3.1 Link Budget Model	6
2.3.2 Link Budget Equation.....	7
2.3.3 Link Budget Performance Measures.....	8
2.3.4 Limitations of Link Budget Analysis.....	9
2.3.5 Relationship between Link Budget and Interference Protection Criteria	9
2.3.6 Receiver Noise Temperature Calculations.....	10
2.4 RECEIVER PERFORMANCE ANALYSIS	13
2.4.1 System Performance Model.....	13
2.4.2 System Performance Measures.....	16
2.4.3 System Performance Analysis Limitations	17
2.4.4 Receiver Performance Analysis Types	19
2.4.5 Receiver Performance Analysis Steps.....	20
2.5 POSSIBLE INTERFERENCE MITIGATION TECHNIQUES	24
SECTION 3 - RF/IF SECTION.....	27
3.1 DESCRIPTION	27
3.2 FDR	28
3.3 BAND-LIMITING EFFECTS ON INTERFERING SIGNALS	31
3.3.1 Frequency Hoppers	32
3.3.2 Pulsed Interfering Signals	32
3.3.3 Digital Interfering Signals	35
3.4 ANALYSIS WITH PULSED SIGNALS.....	35

3.5 SUMMARY 36

SECTION 4 - DESPREADER..... 37

4.1 DESCRIPTION 37

4.2 DIRECT SEQUENCE 38

 4.2.1 Processing Gain..... 39

 4.2.2 Multiple-Access Interference..... 39

4.3 FREQUENCY HOPPING 40

 4.3.1 Processing Gain..... 41

 4.3.2 Multiple-Access Interference..... 41

4.4 TIME HOPPING 42

4.5 SUMMARY 42

SECTION 5 - ANALOG DEMODULATOR..... 43

5.1 INTRODUCTION 43

5.2 VOICE PERFORMANCE MEASURES 43

 5.2.1 Speech Intelligibility and Articulation Index..... 43

 5.2.2 Articulation Score..... 45

5.3 AM VOICE..... 46

 5.3.1 Description..... 46

 5.3.2 Performance 46

 5.3.3 Transfer Function..... 47

 5.3.4 AI Curves 48

5.4 SINGLE SIDEBAND VOICE 51

 5.4.1 Description..... 51

 5.4.2 Transfer Function..... 51

 5.4.3 AI Curves 51

5.5 FM VOICE 55

 5.5.1 Description..... 55

 5.5.2 Performance 56

 5.5.3 Transfer Function..... 57

 5.5.4 AI Curves 58

 5.5.5 FM Voice Co-Channel and Adjacent Channel Interference Analysis 61

5.6 BROADCAST VIDEO TRANSMISSION 65

 5.6.1 Description..... 65

 5.6.2 TASO Curves..... 66

SECTION 6 - DIGITAL DEMODULATOR..... 69

6.1 INTRODUCTION 69

6.2 BINARY SYSTEMS..... 71

6.3 M-ARY SYSTEMS..... 72

6.4 M-ARY SYSTEM PERFORMANCE IN BINARY TERMS 73

6.5 TYPES OF INTERFERENCE..... 75

6.6 PHASE-SHIFT KEYING 75

6.6.1	Description	75
6.6.2	BER Curves	77
6.7	DIFFERENTIAL PHASE-SHIFT KEYING	96
6.7.1	Description	97
6.7.2	BER Curves	97
6.8	FREQUENCY-SHIFT KEYING	108
6.8.1	Description	108
6.8.2	BER Curves	108
6.9	MINIMUM-SHIFT KEYING	120
6.9.1	Description	120
6.9.2	BER Curves	120
6.10	QUASI-BANDLIMITED MINIMUM-SHIFT KEYING	128
6.10.1	Description	128
6.10.2	BER Curves	129
6.11	GAUSSIAN MINIMUM-SHIFT KEYING	136
6.11.1	Description	136
6.11.2	BER Curves	136
6.12	AMPLITUDE-SHIFT KEYING	145
6.12.1	Description	145
6.12.2	BER Curves	146
6.13	QUADRATURE AMPLITUDE-MODULATION	157
6.13.1	Description	157
6.13.2	BER Curves	157
6.14	ORTHOGOANAL FREQUENCY DIVISION MULTIPLEXING	167
6.14.1	Description	167
6.14.2	BER Curves	168
6.15	COMPLEMENTRY CODE KEYING	177
6.15.1	Description	177
6.15.2	BER Curves	177
6.16	PULSE POSITION MODULATION	185
6.16.1	Description	185
6.16.2	BER Curves	185
SECTION 7 - FORWARD ERROR CORRECTION DECODER		193
7.1	INTRODUCTION	193
7.2	HARD DECISION VERSES SOFT DECISION	193
7.3	DECODER PERFORMANCE	194
7.4	TEMPORAL FLUCTUATIONS	194
7.5	BLOCK CODES	194
7.5.1	General Concepts and Terminology	194
7.5.2	BER Calculation for Block Coding FEC	196
7.5.3	Bose-Chaudhurie-Hocquenghem Codes	197

7.5.4	Hamming Code	200
7.5.5	Hadamard Code.....	200
7.5.6	Golay Code.....	203
7.5.7	Reed-Solomon Codes.....	203
7.5.8	Turbo Product Codes.....	211
7.5.9	Low Density Parity Check Codes.....	220
7.5.10	Interleaving	229
7.6	CONVOLUTIONAL CODES.....	231
7.6.1	Description.....	231
7.6.2	Decoding Convolutional-Coded Data.....	232
7.6.3	BER Calculation for Convolutional Coding.....	232
7.6.4	BER Curves	234
7.7	8-ARY PHASE SHIFT KEYING/TRELLIS CODED MODULATION	244
7.7.1	Description.....	244
7.7.2	BER Curves	245
7.8	CONTINUOUS-PHASE MODULATION.....	248
7.8.1	Description.....	248
7.8.2	BER Curves	248
7.9	CONCATENATED CODES.....	251
7.9.1	Description.....	251
7.9.2	BER Curves	251
7.10	TURBO CONVOLUTIONAL CODES.....	260
7.10.1	Description.....	260
7.10.2	Decoding of Turbo Convolutional Codes	261
7.11	ERASURE CODES	268
7.11.1	Description.....	268
7.11.2	Effect of Interference on Erasure Codes.....	269
SECTION 8 - SOURCE DECODER		271
8.1	MULTI-BIT SAMPLING.....	271
8.1.1	Description.....	271
8.1.2	Output Signal-to-Noise.....	273
8.2	SINGLE-BIT SAMPLING	275
8.2.1	Description.....	275
8.2.2	Output Signal-to-Noise Ratio	276
SECTION 9 - SAMPLE RECEIVER ANALYSIS PROBLEMS		279
9.1	RECEIVER PERFORMANCE ANALYSIS EXAMPLE 1.....	279
9.1.1	Approach	279
9.1.2	Models	279
9.1.3	Calculate Input Signal Requirement for System 1	280
9.1.4	Calculate Input Signal Requirement for System 2	280
9.1.5	Comparing the Two Implementations	280

9.2 RECEIVER PERFORMNACE ANALYSIS EXAMPLE 2 280

9.2.1 Approach 281

9.2.2 Operating Environment 281

9.2.3 Equipment Characteristics (for the Desired Signal) 281

9.2.4 Required Performance 282

9.2.5 Received Signal Power Calculation 282

9.2.6 Comparison of Received-Signal Power With Receiver Sensitivity 282

9.2.7 Noise Calculation 283

9.2.8 Interference Calculation 283

9.2.9 Remediation 284

9.3 RECEIVER PERFORMANCE ANALYSIS EXAMPLE 3 284

9.3.1 Background 284

9.3.2 Scenario Description 284

9.3.3 Approach 285

9.3.4 Analysis 285

9.3.5 Conclusion 286

9.4 RECIVER PERFORMANCE ANALYSIS EXAMPLE 4 286

9.4.1 Background 286

9.4.2 Approach 287

9.4.3 Operating Environment 287

9.4.4 Equipment Characteristics 288

9.4.5 Link Budget Analysis 289

9.4.6 Performance Analysis 291

9.5 RECEIVER PERFORMANCE ANALYSIS EXAMPLE 5 292

9.5.1 Background 292

9.5.2 Scenario Description 292

9.5.3 Approach 293

9.5.4 Analysis 293

9.5.5 Conclusions 293

SECTION 10 - REFERENCES 295

APPENDIX A - INTERFERENCE THRESHOLD TABLE 297

APPENDIX B - WIRELESS SYSTEMS SUPPLEMENT 299

B.1. STANDARDS BASED WIRELESS NETWORKS 299

B.2. MOBILE WIRELESS SYSTEMS 299

B.3. P25 LMR PUBLIC SAFETY WIRELESS SYSTEMS 299

B.4. ULTRA-WIDEBAND SYSTEMS 301

B.5. COGNITIVE NETWORKS 303

B.6. MULTI-INPUT MULTI-OUTPUT 304

DISTRIBUTION LIST 305

List of Figures

Figure 2.3-1. Basic Link Budget Model	6
Figure 2.3-2. More Detailed Link Budget Model	6
Figure 2.3-3. System Temperature Model	10
Figure 2.4-1. System Performance Model	14
Figure 2.4-2. Transmission Signaling Model and Definitions	17
Figure 2.4-3. Receiver Performance Model	20
Figure 3.1-1. Illustration of Off-Tune (OFR) and On-Tune (OTR) FDR.....	28
Figure 5.3-1. AI vs. $(S/N)_{in}$ Curves for AM Voice Receiver with ASK Interference	49
Figure 5.3-2. AI vs. $(S/N)_{in}$ Curves for AM Voice Receiver with FSK Interference	50
Figure 5.4-1. AI vs. $(S/N)_{in}$ Curves for SSB Voice Receiver with ASK Interference	53
Figure 5.4-2. AI vs. $(S/N)_{in}$ Curves for SSB Voice Receiver with FSK Interference	54
Figure 5.5-1. AI vs. $(S/N)_{in}$ Curves for FM Voice Receiver with ASK Interference	59
Figure 5.5-2. AI vs. $(S/N)_{in}$ Curves for FM Voice Receiver with FSK Interference	60
Figure 5.5-3. FM Voice Receiver Block Diagram.....	61
Figure 5.5-4. AI vs. $(S/N)_{in}$ Curves for FM Voice Receiver with Co-Channel FM Voice Interference	64
Figure 5.5-5. AI vs. $(S/N)_{in}$ Curves for FM Voice Receiver with Adjacent- Channel FM Voice Interference.....	65
Figure 5.6-1. TASO Score vs. $(S/I)_{in}$ Curves for Broadcast TV Receiver.....	67
Figure 6.4-1. Analytical and Simulation BER Curves for PSK Receiver with M = 8	74
Figure 6.6-1. BER vs. E_b/N_o Curves for PSK Receiver (M = 2) with CW Interference	78
Figure 6.6-2. BER vs. E_b/N_o Curves for PSK Receiver (M = 4) with CW Interference	79
Figure 6.6-3. BER vs. E_b/N_o Curves for PSK Receiver (M = 8) with CW Interference	80
Figure 6.6-4. BER vs. E_b/N_o Curves for PSK Receiver (M = 16) with CW Interference	81
Figure 6.6-5. Pulsed Interference Scenario (Pulse Parameters: $T_p < T_b$; $T_p=0.02T_b$; $PRI=0.7T_b$)	82
Figure 6.6-6. Pulsed Interference Scenario (Pulse Parameters: $T_p < T_b$; $T_p=0.2T_b$; $PRI=318T_b$)	83
Figure 6.6-7. Pulsed Interference Scenario (Pulse Parameters: $T_p > T_b$; $T_p=11T_b$; $PRI=11000T_b$).....	83
Figure 6.6-8. Pulsed Interference Scenario (Pulse Parameters: $T_p > T_b$; $T_p=48T_b$; $PRI=240T_b$)	84

Figure 6.6-9. BER vs. E_b/N_0 Curves for PSK Receiver ($M = 4$) with On-Tune Pulsed Interference Scenario 1 85

Figure 6.6-10. BER vs. E_b/N_0 Curves for PSK Receiver ($M = 4$) with On-Tune Pulsed Interference Scenario 2 86

Figure 6.6-11. BER vs. E_b/N_0 Curves for PSK Receiver ($M = 4$) with On-Tune Pulsed Interference Scenario 3 87

Figure 6.6-12. BER vs. E_b/N_0 Curves for PSK Receiver ($M = 4$) with On-Tune Pulsed Interference Scenario 4 88

Figure 6.6-13. BER vs. E_b/N_0 Curves for PSK Receiver ($M = 4$) with On-Tune Pulsed Broadband AWGN Interference Scenario 5..... 89

Figure 6.6-14. BER vs. E_b/N_0 Curves for PSK Receiver ($M = 4$) with On-Tune Pulsed Broadband AWGN Interference Scenario 6..... 90

Figure 6.6-15. BER vs. E_b/N_0 Curves for PSK Receiver ($M = 4$) with On-Tune Pulsed Broadband AWGN Interference Scenario 7..... 91

Figure 6.6-16. BER vs. E_b/N_0 Curves for PSK Receiver ($M = 4$) with Off-Tune Pulsed Interference Scenario 1 92

Figure 6.6-17. BER vs. E_b/N_0 Curves for PSK Receiver ($M = 4$) with Off-Tune Pulsed Interference Scenario 2 93

Figure 6.6-18. BER vs. E_b/N_0 Curves for PSK Receiver ($M = 4$) with Off-Tune Pulsed Interference Scenario 3 94

Figure 6.6-19. BER vs. E_b/N_0 Curves for PSK Receiver ($M = 4$) with Same as Victim Interference 95

Figure 6.6-20. BER vs. E_b/N_0 Curves for PSK Receiver ($M = 4$) with WiMax (OFDM) Interference 96

Figure 6.7-1. BER vs. E_b/N_0 Curves for DPSK Receiver ($M = 2$) with CW Interference 98

Figure 6.7-2. BER vs. E_b/N_0 Curves for DPSK Receiver ($M = 4$) with CW Interference 99

Figure 6.7-3. BER vs. E_b/N_0 Curves for DPSK Receiver ($M = 8$) with CW Interference 100

Figure 6.7-4. BER vs. E_b/N_0 Curves for DPSK Receiver ($M = 4$) with On-Tune Pulsed Interference Scenario 1 101

Figure 6.7-5. BER vs. E_b/N_0 Curves for DPSK Receiver ($M = 4$) with On-Tune Pulsed Interference Scenario 2 102

Figure 6.7-6. BER vs. E_b/N_0 Curves for DPSK Receiver ($M = 4$) with On-Tune Pulsed Interference Scenario 3 103

Figure 6.7-7. BER vs. E_b/N_0 Curves for DPSK Receiver ($M = 4$) with On-Tune Pulsed Interference Scenario 4 104

Figure 6.7-8. BER vs. E_b/N_0 Curves for DPSK Receiver ($M = 4$) with Off-Tune Pulsed Interference Scenario 1 105

Figure 6.7-9. BER vs. E_b/N_0 Curves for DPSK Receiver ($M = 4$) with Off-Tune Pulsed Interference Scenario 2 106

Figure 6.7-10. BER vs. E_b/N_0 Curves for DPSK Receiver ($M = 4$) with Off-Tune Pulsed Interference Scenario 3 107

Figure 6.8-1. BER vs. E_b/N_0 Curves for CFSK Receiver ($M = 2$) with CW Interference 110

Figure 6.8-2. BER vs. E_b/N_0 Curves for NCFSK Receiver ($M = 2$) with CW Interference 111

Figure 6.8-3. BER vs. E_b/N_0 Curves for NCFSK Receiver ($M = 4$) with CW Interference 112

Figure 6.8-4. BER vs. E_b/N_0 Curves for NCFSK Receiver ($M = 8$) with CW Interference 113

Figure 6.8-5. BER vs. E_b/N_0 Curves for NCFSK Receiver ($M = 2$) with On-Tune Pulsed Interference Scenario 2 114

Figure 6.8-6. BER vs. E_b/N_0 Curves for NCFSK Receiver ($M = 2$) with On-Tune Pulsed Interference Scenario 3 115

Figure 6.8-7. BER vs. E_b/N_0 Curves for NCFSK Receiver ($M = 2$) with On-Tune Pulsed Interference Scenario 4 116

Figure 6.8-8. BER vs. E_b/N_0 Curves for NCFSK Receiver ($M = 2$) with Off-Tune Pulsed Interference Scenario 2 117

Figure 6.8-9. BER vs. E_b/N_0 Curves for NCFSK Receiver ($M = 2$) with Off-Tune Pulsed Interference Scenario 3 118

Figure 6.8-10. BER vs. E_b/N_0 Curves for NCFSK Receiver ($M = 2$) with Same as Victim Interference 119

Figure 6.9-1. BER Curves for an MSK Receiver with CW Interference 122

Figure 6.9-2. BER vs. E_b/N_0 Curves for MSK Receiver with On-Tune Pulsed Interference Scenario 2 123

Figure 6.9-3. BER vs. E_b/N_0 Curves for MSK Receiver with On-Tune Pulsed Interference Scenario 3 124

Figure 6.9-4. BER vs. E_b/N_0 Curves for MSK Receiver with On-Tune Pulsed Interference Scenario 4 125

Figure 6.9-5. BER vs. E_b/N_0 Curves for MSK Receiver with Off-Tune Pulsed Interference Scenario 2 126

Figure 6.9-6. BER vs. E_b/N_0 Curves for MSK Receiver with Off-Tune Pulsed Interference Scenario 3 127

Figure 6.10-1. BER vs. E_b/N_0 Curves for QBL-MSK Receiver with CW Interference 130

Figure 6.10-2. BER vs. E_b/N_0 Curves for QBL-MSK Receiver with On-Tune Pulsed Interference Scenario 2 131

Figure 6.10-3. BER vs. E_b/N_0 Curves for QBL-MSK Receiver with On-Tune Pulsed Interference Scenario 3 132

Figure 6.10-4. BER vs. E_b/N_0 Curves for QBL-MSK Receiver with On-Tune Pulsed Interference Scenario 4 133

Figure 6.10-5. BER vs. E_b/N_0 Curves for QBL-MSK Receiver with Off-Tune Pulsed Interference Scenario 2 134

Figure 6.10-6. BER vs. E_b/N_0 Curves for QBL-MSK Receiver with Off-Tune Pulsed Interference Scenario 3 135

Figure 6.11-1. BER vs. E_b/N_0 Curves for GMSK Receiver with On-Tune Broadband AWGN Interference 137

Figure 6.11-2. BER vs. E_b/N_0 Curves for GMSK Receiver with On-Tune CW Interference 138

Figure 6.11-3. BER vs. E_b/N_0 Curves for GMSK Receiver with On-Tune Pulsed Interference Scenario 1 139

Figure 6.11-4. BER vs. E_b/N_0 Curves for GMSK Receiver with On-Tune Pulsed Interference Scenario 2 140

Figure 6.11-5. BER vs. E_b/N_0 Curves for GMSK Receiver with On-Tune Pulsed Interference Scenario 3 141

Figure 6.11-6. BER vs. E_b/N_0 Curves for GMSK Receiver with On-Tune Pulsed Interference Scenario 4 142

Figure 6.11-7. BER vs. E_b/N_0 Curves for GMSK Receiver with Off-Tune Pulsed Interference Scenario 2 143

Figure 6.11-8. BER vs. E_b/N_0 Curves for GMSK Receiver with Off-Tune Pulsed Interference Scenario 3 144

Figure 6.12-1. BER vs. E_b/N_0 Curves for Coherent Unipolar ASK Receiver ($M = 2$) with CW Interference..... 147

Figure 6.12-2. BER vs. E_b/N_0 Curves for Coherent Unipolar ASK Receiver ($M = 4$) with CW Interference..... 148

Figure 6.12-3. BER vs. E_b/N_0 Curves for Coherent Bipolar ASK Receiver ($M = 4$) with CW Interference..... 149

Figure 6.12-4. BER vs. E_b/N_0 Curves for Coherent Bipolar ASK Receiver ($M = 8$) with CW Interference..... 150

Figure 6.12-5. BER vs. E_b/N_0 Curves for Noncoherent ASK Receiver..... 151

Figure 6.12-6. BER vs. E_b/N_0 Curves for ASK Receiver with On-Tune Pulsed Interference Scenario 2 152

Figure 6.12-7. BER vs. E_b/N_0 Curves for ASK Receiver with On-Tune Pulsed Interference Scenario 3 153

Figure 6.12-8. BER vs. E_b/N_0 Curves for ASK Receiver with On-Tune Pulsed Interference Scenario 4 154

Figure 6.12-9. BER vs. E_b/N_0 Curves for ASK Receiver with Off-Tune Pulsed Interference Scenario 2 155

Figure 6.12-10. BER vs. E_b/N_0 Curves for ASK Receiver with Off-Tune Pulsed Interference Scenario 3 156

Figure 6.13-1. BER vs. E_b/N_0 Curves for QAM Receiver ($M = 16$) with CW Interference 159

Figure 6.13-2. BER vs. E_b/N_0 Curves for QAM Receiver ($M = 64$) with CW Interference 160

Figure 6.13-3. BER vs. E_b/N_0 Curves for QAM Receiver ($M = 16$) with On-Tune Pulsed Interference Scenario 2 161

Figure 6.13-4. BER vs. E_b/N_0 Curves for QAM Receiver ($M = 16$) with On-Tune Pulsed Interference Scenario 3 162

Figure 6.13-5. BER vs. E_b/N_0 Curves for QAM Receiver ($M = 16$) with On-Tune Pulsed Interference Scenario 4 163

Figure 6.13-6. BER vs. E_b/N_0 Curves for QAM Receiver ($M = 16$) with Off-Tune Pulsed Interference Scenario 2 164

Figure 6.13-7. BER vs. E_b/N_0 Curves for QAM Receiver ($M = 16$) with Off-Tune Pulsed Interference Scenario 3 165

Figure 6.13-8. BER vs. E_b/N_0 Curves for QAM Receiver ($M = 16$) with Same as Victim Interference..... 166

Figure 6.14-1. OFDM Implementation 167

Figure 6.14-2. BER vs. E_b/N_0 Curves for OFDM Receiver with On-Tune Broadband AWGN Interference..... 169

Figure 6.14-3. BER vs. E_b/N_0 Curves for OFDM Receiver with On-Tune CW Interference 170

Figure 6.14-4. BER vs. E_b/N_0 Curves for OFDM Receiver with On-Tune Pulsed Interference Scenario 2 171

Figure 6.14-5. BER vs. E_b/N_0 Curves for OFDM Receiver with On-Tune Pulsed Interference Scenario 3 172

Figure 6.14-6. BER vs. E_b/N_0 Curves for OFDM Receiver with On-Tune Pulsed Interference Scenario 4 173

Figure 6.14-7. BER vs. E_b/N_0 Curves for OFDM Receiver with Off-Tune Pulsed Interference Scenario 2 174

Figure 6.14-8. BER vs. E_b/N_0 Curves for OFDM Receiver with Off-Tune Pulsed Interference Scenario 3 175

Figure 6.14-9. BER vs. E_b/N_0 Curves for OFDM Receiver with Same as Victim Interference 176

Figure 6.15-1. BER vs. E_b/N_0 Curves for CCK Receiver with On-Tune Broadband AWGN Interference..... 178

Figure 6.15-2. BER vs. E_b/N_0 Curves for CCK Receiver with On-Tune CW Interference 179

Figure 6.15-3. BER vs. E_b/N_0 Curves for CCK Receiver with On-Tune Pulsed Interference Scenario 2 180

Figure 6.15-4. BER vs. E_b/N_0 Curves for CCK Receiver with On-Tune Pulsed Interference Scenario 3 181

Figure 6.15-5. BER vs. E_b/N_0 Curves for CCK Receiver with On-Tune Pulsed Interference Scenario 4 182

Figure 6.15-6. BER vs. E_b/N_0 Curves for CCK Receiver with Off-Tune Pulsed Interference Scenario 2 183

Figure 6.15-7. BER vs. E_b/N_0 Curves for CCK Receiver with Off-Tune Pulsed Interference Scenario 3 184

Figure 6.16-1. BER vs. E_b/N_0 Curves for PPM ($M = 4$) Receiver with On-Tune Broadband AWGN Interference..... 186

Figure 6.16-2. BER vs. E_b/N_0 Curves for PPM ($M = 4$) Receiver with On-Tune CW Interference 187

Figure 6.16-3. BER vs. E_b/N_0 Curves for PPM ($M = 4$) Receiver with On-Tune Pulsed Interference Scenario 2 188

Figure 6.16-4. BER vs. E_b/N_0 Curves for PPM ($M = 4$) Receiver with On-Tune Pulsed Interference Scenario 3 189

Figure 6.16-5. BER vs. E_b/N_0 Curves for PPM ($M = 4$) Receiver with On-Tune Pulsed Interference Scenario 4 190

Figure 6.16-6. BER vs. E_b/N_0 Curves for PPM ($M = 4$) Receiver with Off-Tune Pulsed Interference Scenario 2 191

Figure 6.16-7. BER vs. E_b/N_0 Curves for PPM ($M = 4$) Receiver with Off-Tune Pulsed Interference Scenario 3 192

Figure 7.5-1. Output BER vs. Input BER Curve for Hard-decision (255, 239) BCH Decoder 199

Figure 7.5-2. Output BER vs. Input BER Curve for Hard-decision (8, 4) Hamming Decoder 201

Figure 7.5-3. BER vs. E_b/N_0 Curves for Soft-decision (8, 4) Hamming Decoder 202

Figure 7.5-4. Output BER vs. Input BER Curve for Hard-decision (64, 6) Hadamard Decoder 204

Figure 7.5-5. BER vs. E_b/N_0 Curves for Soft-decision (64, 6) Hadamard Decoder 205

Figure 7.5-6. Output BER vs. Input BER Curve for Hard-decision (24, 12) Golay Decoder 206

Figure 7.5-7. BER vs. E_b/N_0 Curves for Soft-decision (24, 12) Golay Decoder 207

Figure 7.5-8. Output BER vs. Input BER Curve for Hard-decision (255, 223) RS Decoder 209

Figure 7.5-9. BER Curves vs. E_b/N_0 for (255, 223) RS Coded PSK Receiver ($M=4$) with On-Tune Broadband AWGN Interference 210

Figure 7.5-10. Construction of Product Code 211

Figure 7.5-11. BER vs. E_b/N_0 Curves for $(64, 57)^2$ TPC PSK Receiver ($M = 4$) with On-Tune Broadband AWGN Interference 212

Figure 7.5-12. BER vs. E_b/N_0 Curves for $(64, 57)^2$ TPC PSK Receiver ($M = 4$) with On-Tune CW Interference 213

Figure 7.5-13. BER vs. E_b/N_0 Curves for $(64, 57)^2$ TPC PSK Receiver ($M = 4$) with On-Tune Pulsed Interference Scenario 1 214

Figure 7.5-14. BER vs. E_b/N_0 Curves for $(64, 57)^2$ TPC PSK Receiver ($M = 4$) with On-Tune Pulsed Interference Scenario 2 215

Figure 7.5-15. BER vs. E_b/N_0 Curves for $(64, 57)^2$ TPC PSK Receiver ($M = 4$) with On-Tune and Pulsed Interference Scenario 3 216

Figure 7.5-16. BER vs. E_b/N_0 Curves for $(64, 57)^2$ TPC PSK Receiver ($M = 4$) with Off-Tune Pulsed Interference Scenario 1 217

Figure 7.5-17. BER vs. E_b/N_0 Curves for $(64, 57)^2$ TPC PSK Receiver ($M = 4$) with Off-Tune Pulsed Interference Scenario 2 218

Figure 7.5-18. BER vs. E_b/N_0 Curves for $(64, 57)^2$ TPC PSK Receiver ($M = 4$) with Off-Tune Pulsed Interference Scenario 3 219

Figure 7.5-19. Tanner Graph Corresponding to the Parity Check Matrix H 220

Figure 7.5-20. BER vs. E_b/N_0 Curves for a (64800, 32400) LDPC coded PSK Receiver ($M = 4$) with On-Tune Broadband AWGN Interference 222

Figure 7.5-21. BER vs. E_b/N_0 Curves for a (64800, 32400) LDPC coded PSK Receiver ($M = 4$) with On-Tune CW Interference 223

Figure 7.5-22. BER vs. E_b/N_0 Curves for a (64800, 32400) LDPC coded PSK Receiver ($M = 4$) with On-Tune Pulsed Interference Scenario 2 224

Figure 7.5-23. BER vs. E_b/N_0 Curves for a (64800, 32400) LDPC coded PSK Receiver ($M = 4$) with On-Tune Pulsed Interference Scenario 3 225

Figure 7.5-24. BER vs. E_b/N_0 Curves for a (64800, 32400) LDPC coded PSK Receiver ($M = 4$) with On-Tune Pulsed Interference Scenario 4 226

Figure 7.5-25. BER vs. E_b/N_0 Curves for a (64800, 32400) LDPC coded PSK Receiver ($M = 4$) with Off-Tune Pulsed Interference Scenario 2 227

Figure 7.5-26. BER vs. E_b/N_0 Curves for a (64800, 32400) LDPC coded PSK Receiver ($M = 4$) with Off-Tune Pulsed Interference Scenario 3 228

Figure 7.5-27. Pulsed Interference Without Interleaving..... 229

Figure 7.5-28. Pulsed Interference With Interleaving..... 230

Figure 7.6-1. A (1/2, 3) Convolutional Encoder..... 231

Figure 7.6-2. BER vs. E_b/N_0 Curves for Soft-decision (1/2, 7) Viterbi Decoder..... 235

Figure 7.6-3. BER vs. E_b/N_0 Curves for Rate 1/2 Convolutional Coded QPSK Receiver with On-Tune Broadband AWGN Interference 236

Figure 7.6-4. BER vs. E_b/N_0 Curves for Rate 1/2 Convolutional Coded QPSK Receiver with On-Tune CW Interference..... 237

Figure 7.6-5. BER vs. E_b/N_0 Curves for Rate 1/2 Convolutional Coded QPSK Receiver with On-Tune Pulsed Interference Scenario 1..... 238

Figure 7.6-6. BER vs. E_b/N_0 Curves for Rate 1/2 Convolutional Coded QPSK Receiver with On-Tune Pulsed Interference Scenario 2..... 239

Figure 7.6-7. BER vs. E_b/N_0 Curves for Rate 1/2 Convolutional Coded QPSK Receiver with On-Tune Pulsed Interference Scenario 3..... 240

Figure 7.6-8. BER vs. E_b/N_0 Curves for Rate 1/2 Convolutional Coded QPSK Receiver with On-Tune Pulsed Interference Scenario 4..... 241

Figure 7.6-9. BER vs. E_b/N_0 Curves for Rate 1/2 Convolutional Coded QPSK Receiver with Off-Tune Pulsed Interference Scenario 2..... 242

Figure 7.6-10. BER vs. E_b/N_0 Curves for Rate 1/2 Convolutional Coded QPSK Receiver with Off-Tune Pulsed Interference Scenario 3..... 243

Figure 7.7-1. Trellis Coded Modulation..... 244

Figure 7.7-2. Constellation Mapping 245

Figure 7.7-3. BER vs. E_b/N_0 Curves for a 8PSK/TCM Receiver ($M = 8$) with On-Tune Broadband AWGN Interference..... 246

Figure 7.7-4. BER vs. E_b/N_0 Curves for a 8PSK/TCM Receiver ($M = 8$) with On-Tune CW Interference 247

Figure 7.8-1. BER vs. E_b/N_0 Curves for Binary CPM Decoder (Modulation Index 1/2) 249

Figure 7.8-2. BER vs. E_b/N_0 Curves for 4-ary CPM Decoder (Modulation Index 1/6) 250

Figure 7.9-1. Concatenated Codes..... 251

Figure 7.9-2. BER vs. E_b/N_0 Curves for ((223,255) RS + rate 1/2 convolution) Coded PSK Receiver ($M = 4$) with On-Tune Broadband AWGN Interference 252

Figure 7.9-3. BER vs. E_b/N_0 Curves for ((223,255) RS + rate 1/2 convolution) Coded PSK Receiver ($M = 4$) with On-Tune CW Interference..... 253

Figure 7.9-4. BER vs. E_b/N_0 Curves for ((223,255) RS + rate 1/2 convolution) Coded PSK Receiver ($M = 4$) with On-Tune Pulsed Interference Scenario 1 254

Figure 7.9-5. BER vs. E_b/N_o Curves for ((223,255) RS + rate $\frac{1}{2}$ convolution) Coded PSK Receiver (M = 4) with On-Tune Pulsed Interference Scenario 2 255

Figure 7.9-6. BER vs. E_b/N_o Curves for ((223,255) RS + rate $\frac{1}{2}$ convolution) Coded PSK Receiver (M = 4) with On-Tune Pulsed Interference Scenario 3 256

Figure 7.9-7. BER vs. E_b/N_o Curves for ((223,255) RS + rate $\frac{1}{2}$ convolution) Coded PSK Receiver (M = 4) with On-Tune Pulsed Interference Scenario 4 257

Figure 7.9-8. BER vs. E_b/N_o Curves for ((223,255) RS + rate $\frac{1}{2}$ convolution) Coded PSK Receiver (M = 4) with Off-Tune Pulsed Interference Scenario 2 258

Figure 7.9-9. BER vs. E_b/N_o Curves for ((223,255) RS + rate $\frac{1}{2}$ convolution) Coded PSK Receiver (M = 4) with Off-Tune Pulsed Interference Scenario 3 259

Figure 7.10-1. 1/3 PCCC Encoder 260

Figure 7.10-2. Iterative Decoding using MAP Algorithm 262

Figure 7.10-3. BER vs. E_b/N_o Curves for Rate 1/3 TCC Coded QPSK Receiver with On-Tune Broadband AWGN Interference 263

Figure 7.10-4. BER vs. E_b/N_o Curves for Rate 1/3 TCC Coded PSK Receiver (M = 4) with On-Tune CW Interference 264

Figure 7.10-5. BER vs. E_b/N_o Curves for Rate 1/3 TCC Coded PSK Receiver (M = 4) with On-Tune Pulsed Interference Scenario 2 265

Figure 7.10-6. BER vs. E_b/N_o Curves for Rate 1/3 TCC Coded PSK Receiver (M = 4) with On-Tune Pulsed Interference Scenario 4 266

Figure 7.10-7. BER vs. E_b/N_o Curves for Rate 1/3 TCC Coded PSK Receiver (M = 4) with Off-Tune Pulsed Interference Scenario 2 267

Figure 7.11-1. LT Encoding Process 269

Figure 7.11-2. Notional Plot Illustrating the Effect of a Pulsed Interferer on Erasure Codes with $PRI \gg T_{pack}$ 270

Figure 7.11-3. Notional Plot Illustrating the Effect of a Pulsed Interferer on Erasure Codes with $PRI < T_{pack}$ 270

Figure 8.1-1. Block Diagram for PCM ADC and DAC 272

Figure 8.1-2. Output S/N vs. Input BER for PCM DAC 274

Figure 8.2-1. Block Diagram for DPCM Encoder 275

Figure 8.2-2. Output S/N vs. Input BER for 16-kbit CVSD 277

Figure 9.4-1. Pictorial Representation of Major Systems in the 1710-1850 MHz Frequency Band 287

Figure B.3-1. P25 C4FM and CQPSK Modulators 300

Figure B.4-1. Illustration of UWB Fractional Bandwidth 302

List of Tables

Table 2.4-1. Summary of Widely Used Propagation Models	19
Table 2.4-2. Receiver Performance Degradation Analysis Approaches	21
Table 2.5-1. Summary of Interference Mitigation Techniques	24
Table 3.3-1. RF/IF Output Signals for Pulsed Interfering Input Signals	33
Table 5.2-1. Weighting Factors for AI Calculations.....	45
Table 5.6-1. TASO Score Definition	66
Table 7.5-1. Linear, Systematic (7, 4) Block Code	195
Table 7.5-2. Performance of (7, 4) Linear Block Code With $t = 1$	196
Table 7.5-3. BCH Code Parameters for $n \leq 63$	198
Table 7.6-1. Rate $R = 1/2$ Convolutional Codes	232
Table 7.6-2. Transfer Functions for $R = 1/2$ Convolutional Codes.....	233
Table 7.6-3. Derivative Polynomials for $R = 1/2$ Convolutional Codes.....	233
Table 9.4-1. AN/MRC-142 Radio Parameters	288
Table 9.4-2. Examples of JTRS Radios and Waveforms.....	289
Table B.3-1. Mapping Between Symbols and Bits in P25 C4FM and CQPSK.....	301

GLOSSARY

τ	Pulse duration
ADC	Analog-to-Digital Converter
ADM	Adaptive Delta Modulation
AI	Articulation Index
ALC	Automatic Level Control
AM	Amplitude Modulation
APSK	Amplitude and Phase-Shift Keying
AS	Articulation Score
ASK	Amplitude-Shift Keying
AWGN	Additive White Gaussian Noise
BCH	Bose-Chaudhuri-Hocquenghem
BER	Bit Error Rate
BPH	Best Practices Handbook
BPSK	Binary Phase Shift Keying
CCK	Complementary Code Keying
CDMA	Code Division Multiple Access
C4FM	Constant Envelope 4-Level Frequency Modulation
CFSK	Coherent Frequency-Shift Keying
C/I	Carrier-to-Interference power ratio
CN	Cognitive Network
CODEC	Coder-Decoder
CPM	Continuous-Phase Modulation
CQPSK	Compatible Quadrature Phase Shift Keying
CR	Cognitive Radio
CVSD	Continuously Variable Slope Delta
CW	Continuous Wave
DAC	Digital-to-Analog Converter
dB	Decibel
dB _i	Decibels relative to an isotropic antenna
dB _m	Decibels relative to one milliwatt
dBW	Decibels relative to one Watt
DM	Delta Modulation
DoD	Department of Defense
DPCM	Differential Pulse Code Modulation
DPSK	Differential Phase-Shift Keying
DS	Direct Sequence
DSA	Dynamic Spectrum Access
DSB	Double Sideband
DVB	Direct Video Broadcast
DVB-S2	Direct Video Broadcast Standard-2
E _b	Energy per bit

E_b/N_o	Ratio of bit energy to noise power density
8PSK	Eight - Phase Shift Keying
EIRP	Effective Isotropic Radiated Power
EMC	Electromagnetic Compatibility
EPLRS	Enhanced Position Location Reporting System
ERP	Effective Radiated Power
FCC	Federal Communications Commission
FDM	Frequency Division Multiplexing
FDMA	Frequency Division Multiple Access
FDR	Frequency Dependent Rejection
FEC	Forward Error Correction
FM	Frequency Modulation
FS	Fixed Systems
FSK	Frequency-Shift Keying
GBS	Global Broadband Service
GMR	Ground Mobile Radio
GMSK	Gaussian Minimum Shift Keying
GPS	Global Positioning System
G_R	Receive Antenna Gain
G_T	Transmit Antenna Gain
G/T	Gain-to-Noise Temperature ratio (Figure of Merit)
I	Interference power
ICM	Interference Conflict Margin
IF	Intermediate Frequency
IFFT	Inverse Fast Fourier Transform
IMT	International Mobile Telecommunications
I/N	Interference power to Receiver Noise power ratio
I_o	Interference Power Density
IPC	Interference Protection Criteria
IR	Impulse Radio
ITU	International Telecommunications Union
JSC	Joint Spectrum Center
JTRS	Joint Tactical Radio System
k	Boltzmann's Constant
LDPC	Low Density Parity Check
LMR	Land Mobile Radio
LNA	Low Noise Amplifier
LOS	Line-of-Sight
L_p	Propagation Loss
LT	Luby Transform

MAP	Maximum-a-Posteriori
MB-OFDM	Multiband Orthogonal Frequency Division Multiplexing
MDRS	Mobile Digital Radio Systems
MIMO	Multiple-Input Multiple-Output
MODEM	Modulator-Demodulator
MSK	Minimum-Shift Keying
MU-MIMO	Multi-User Multiple-Input Multiple-Output (MIMO)
N	Noise Power
NB	Narrowband
NCFSK	Non-Coherent Frequency-Shift Keying
NF	Noise Figure
N_0	Noise Power Density
NTIA	National Telecommunications and Information Administration
OFDM	Orthogonal Frequency Division Multiplexing
OFR	Off-Frequency Rejection
OOK	On-Off Keying
OQPSK	Offset Quadrature Phase-Shift Keying
OTR	On-Tune Rejection
P25	Project 25
PAM	Pulse Amplitude Modulation
PCCC	Parallel Concatenated Convolutional Codes
PCM	Pulse Code Modulation
PN	Pseudorandom-Noise
PPM	Pulse Position Modulation
PRF	Pulse Repetition Frequency
PRI	Pulse Repetition Interval
PSD	Power Spectral Density
PSK	Phase-Shift Keying
P_T	Transmitter Power (at power amplifier output)
QAM	Quadrature Amplitude-Modulation
QBL-MSK	Quasi-Bandlimited Minimum-Shift Keying
QoS	Quality-of-Service
QPSK	Quadrature Phase-Shift Keying
R_b	Uncoded Bit Rate
R_{baud}	Baud Rate (modulation symbol rate)
RF	Radio Frequency
RMS	Root-Mean-Square
R_s	Symbol Rate (after encoder)
RS	Reed-Solomon
RSC	Recursive Systematic Convolutional
RTM	Ray Tracing Model

SA	Smart Antenna
SATCOM	Satellite Communications
SDR	Software Defined Radio
SEM	Spherical Earth Model
SER	Symbol Error Rate
SINCGARS	Single Channel Ground Air Radio System
S/I	Signal-to-Interference power ratio
16QAM	16-ary Quadrature Amplitude-Modulation
S/N	Signal-to-Noise ratio
SRW	Soldier Radio Waveform
SSB	Single Sideband
SU-MIMO	Single-User Multiple-Input Multiple-Output (MIMO)
TASO	Television Allocation Study Organization
TCC	Turbo Convolutional Code
TCM	Trellis-Coded Modulation
T_e	Effective Noise Temperature
3G	3 rd Generation
TPC	Turbo Product Code
TRR	Tactical Radio Relay
UWB	Ultra-Wideband
W-CDMA	Wideband Code Division Multiple Access
WER	Word Error Rate
WiMax	Worldwide Interoperability for Microwave Access
WLAN	Wireless Local Area Network
WNW	Wideband Networking Waveform

SECTION 1 - INTRODUCTION

1.1 BACKGROUND

In May 2003, President Bush established the Spectrum Policy Initiative to promote the development and implementation of a United States spectrum policy for the 21st Century. In response to the Spectrum Policy Initiative, the Secretary of Commerce established a Federal Government Spectrum Task Force and initiated a series of public meetings to address policies affecting spectrum use by the federal government, state and local governments, and the private sector. The recommendations resulting from these activities were included in two reports released by the Secretary of Commerce in June 2004.¹ In November 2004, the President directed the federal agencies to develop a plan to implement the 24 recommendations contained in the reports.² One of the recommendations directed the National Telecommunications and Information Administration (NTIA) to develop a handbook documenting best practices in spectrum engineering that will be recognized by all regulatory authorities in the United States. The Best Practices Handbook (BPH) will address the electromagnetic compatibility (EMC) analysis process. Establishing receiver performance degradation levels is required to perform an EMC analysis. The NTIA requested that the Defense Spectrum Organization/Joint Spectrum Center (JSC) expand and enhance the Communications Receiver Performance Degradation Handbook such that it could be included as part of the BPH.

1.2 PURPOSE OF THE HANDBOOK

The purpose of the Handbook is to provide the radio frequency (RF) analyst with the capability to calculate the effects of noise and interference on RF communications receivers. The Handbook provides a method for evaluating the effect of simple and complex interference scenarios on communications receiver performance. For interference scenarios which do not fit conveniently into the scenarios addressed directly in this Handbook, techniques are presented in which the receiver is modeled as a sequence of modules and each module has a *transfer function* that relates the module outputs to the module inputs. By consecutively analyzing each module in the sequence, the analyst can then relate the receiver outputs (performance) to the receiver inputs (signal characteristics).

1.3 OVERVIEW OF HANDBOOK CONTENTS

Section 2 describes the general procedures for performing a communications receiver performance analysis. It introduces the fundamental concepts and describes the receiver model. It does not include detailed descriptions for the individual modules within the receiver.

Section 3 provides a detailed description of the RF/Intermediate Frequency (IF) section. This first module of the receiver is designed to amplify the desired signal, convert it to an IF, and filter out interference and noise.

¹Department of Commerce. *Spectrum Policy for the 21st Century – The President’s Spectrum Policy Initiative: Report 1, Report 2. June 2004.*

²Department of Commerce. *White House Executive Memorandum, Subject: Improving Spectrum Management for the 21st Century. 23 November 2004. The latest released document for this subject is Spectrum Management for the 21st Century – Plan to Implement Recommendations of the President’s Spectrum Policy Initiative. March 2006.*

Section 4 describes the despreader module in spread spectrum receivers. It specifies how the spread spectrum processing gain can be calculated. It also provides information that can be used to analyze spread spectrum multiple-access systems.

Sections 5 and 6 describe the demodulator module. They provide plots that characterize performance as a function of the input signal-to-interference power ratios (S/I). Analog voice and broadcast television receivers are considered in Section 5 and digital receivers are considered in Section 6.

Section 7 describes forward error correction (FEC) decoders, which use redundancy bits to reduce the bit-error rate (BER) by correcting some of the bit errors introduced by interference and noise. It provides plots of output BER vs. input BER for several types of FEC decoders.

Section 8 describes source decoders, which convert the information bit sequence to the final format at the receiver output. For a digital voice system, this format is an analog voice waveform. This section provides plots that relate output signal quality to the input BER.

Section 9 presents examples that demonstrate how this Handbook can be used to perform a receiver analysis.

1.4 HOW TO USE THIS HANDBOOK

The first step in using this Handbook is to learn about the communications receiver performance analysis model discussed in Section 2. That section introduces some basic concepts and terminology and sets the context in which a receiver analysis may be performed. It also discusses the limitations and scope of the model. It displays the general structure of the receiver model as a sequence of distinct modules, each of which performs a specific signal-processing function.

The second step in using the Handbook is to actually perform a receiver analysis. The analysis objective is either to determine a value for a receiver performance measure (such as BER) for a given set of input signal conditions or, conversely, to determine the input signal conditions that would yield a given performance value.

The receiver modules are represented in the Handbook by transfer functions, which are organized by module in Sections 3 through 8. Section 2.4.5 lists the specific steps to follow in using these transfer functions to perform an analysis. Section 9 presents receiver analysis examples.

SECTION 2 - ANALYSIS PROCEDURES

This section describes the procedures for performing a communications receiver performance analysis. To set the context, RF system types and RF signal types are first introduced followed by basic analysis concepts including a simple link budget analysis model. The receiver performance analysis model, which is the subject of this Handbook, is then presented

2.1 RF SYSTEM TYPES

The focus of this Handbook is on RF communications systems. RF communications systems are designed to send a message from one point to another by converting the message to an RF signal and transmitting that signal over a transmission medium to a receiver that will convert it back into usable information.

RF communications systems come in many varieties and can be described in many different ways such as fixed or mobile, analog or digital, terrestrial or space / air-based, standards-based or custom / unique, just to name a few. The subsections below describe a small number of general system types into which the majority of communications systems fall. Appendix B provides supplemental information on more specific RF system types that are particularly relevant in today's RF environment.

The RF spectrum is used for many purposes other than communications. Radio navigation, radiolocation, tracking, control, and measurement are examples of such non-communications uses. The focus of this Handbook is on RF communications systems and therefore all the analysis, results and discussions are presented within a communications context. However, the concepts and data presented here can be applied to RF systems in general.

2.1.1 Point-to-Point

Point-to-point is the most basic RF communications system. It consists of a transmitter at one location, a receiver at another location, and the channel through which the RF signal propagates. This permits directional antennas to be used for both the transmitter and receiver. The use of directional antennas allows use of lower transmitter power and in many cases effectively isolates the users from lateral sources of interference. An example of a point-to-point system is a microwave radio relay link.

A point-to-point communications system forms the most basic communications link.

2.1.2 Point-to-Multipoint

Point-to-multipoint is another common type of RF communications system. It typically has one transmitter and many receivers located at different locations within the transmission range of the transmitter. The transmitter antenna is often omni-directional and the transmitter must therefore supply sufficient power to cover the desired receive area. Each transmitter-receiver pair constitutes an independent communications link, and a link analysis may be performed for each one. Point-to-multipoint systems include fixed or generally fixed transmitter and receivers.

The term point-to-multipoint is also used to describe the reciprocal scenario of many transmitters and a single receiver.

Examples of point-to-multipoint systems include a Direct Video Broadcast (DVB) system, a Very Small Aperture Terminal system, a wireless “last mile” internet service and an ocean buoy monitoring system.

2.1.3 Multipoint-to-Multipoint

A multipoint-to-multipoint RF communications system will allow any node of the network to communicate with any other node. Such systems are also referred to as *ad-hoc* or *mesh* networks. While the true distinction of multipoint-to-multipoint systems lies within the network algorithms and protocols used within the system, these systems do represent a unique RF communications system type.

Multipoint-to-multipoint systems are far less prevalent than point-to-point and point-to-multipoint systems and represent an emerging technology. Examples of a multipoint-to-multipoint communications system may include disruption tolerant networks and peer-to-peer networks. Multipoint-to-multipoint systems are commonly implemented within the context of Wireless Local Area Network (WLAN) and 3rd Generation (3G) deployments.

2.1.4 Mobile

A mobile system is defined as a system in which at least one component (transmitter or receiver) is mobile. Mobile systems require that the antennas not be constrained to favor one fixed direction over another. This can be accomplished very simply by utilizing omni-directional antennas. Alternatively, smart antennas can be used to adapt to changes in the direction of propagation. This adaptation can be accomplished physically, by moving the antennas, or electrically, by means of steerable-beam arrays. Examples of mobile systems may include Worldwide Interoperability for Microwave Access (WiMax) systems, mobile telephone systems, public safety mobile radio systems, position location reporting systems and Global Positioning System (GPS) augmentation systems (GPS error message broadcast).

2.2 SIGNAL TYPES

RF signal types are varied and can be described and grouped in many ways. Example groupings may include desired or undesired; continuous or intermittent; random or deterministic; narrowband or broadband; modulated or non-modulated, to name a few.

Since the specific characteristics of the signal determine how it may interact with the receiver, it is beneficial to group signals into several fundamental categories, each with their own unique impact to receiver performance.

2.2.1 Noise

Noise is present in every practical RF system component and in every propagation channel. Noise imposes practical limits on RF communications because it is always necessary for the receiver to distinguish the desired signal from the noise. Consequently, RF analysis results are often expressed as the ratio of the desired signal power to the noise power.

Noise can be modeled in the time domain as a signal whose amplitude varies according to the Gaussian probability distribution, or it can be modeled in the frequency domain as a signal that has a constant magnitude at all frequencies within the receiver band.

Interfering (undesired) signals are sometimes modeled as noise signals if the bandwidth of the interfering signal is much wider than the receiver baseband bandwidth.

2.2.2 Continuous-Wave Signal

A continuous-wave (CW) signal is ideally a sine wave with a constant-amplitude and a single discrete frequency. Its real manifestations will approximate this ideal within the realizable constraints imposed by the signal generation system and the channel characteristics. CW signals are used as RF carriers, beacons, and reference signals. Interfering (undesired) signals are sometimes modeled as CW signals if the bandwidth of the interfering signal is much smaller than the receiver bandwidth.

2.2.3 Modulated Signal

If one signal is used to control the amplitude, frequency, phase, or another property of a second signal, then this process is called *modulation* and the resulting signal is called a modulated signal. Communications signals are typically modulated signals and the modulation process is used to convey information. There are many modulation schemes, each with certain advantages and disadvantages with respect to system performance. This Handbook includes analysis results for many common modulation schemes. The emission bandwidth of a modulated signal will depend on the modulation technique as well as on the data rate.

2.2.4 Pulsed Signal

A pulsed signal is defined as a signal which repeatedly cycles between a non-zero instantaneous power state and a zero instantaneous power state. The characteristics of the cycling are typically fixed and deterministic, however, random or non-deterministic manifestations are also possible. When the cycling characteristics are fixed, the terms duty cycle, Pulse Repetition Interval (PRI), Pulse Repetition Frequency (PRF) and pulse duration are commonly used to describe the signal. A pulsed signal is further described by its peak power in addition to its average power. A common source of pulsed signals (or of apparent pulsed signals) are radiolocation (i.e., radar) and frequency-hopping transmitters.

A simple approach to analyzing pulsed signals is to separately analyze the time periods with non-zero power content and the time periods with no power content. This approach will be sufficiently accurate in some circumstances however it may not be appropriate for all cases. One of the goals of this Handbook is to provide a receiver performance analysis method that is applicable to all cases.

It is worth noting that a pulsed signal may utilize pulse modulation. In general, the pulse modulation is Frequency Modulation (FM) with some variation such as linear FM chirp. Pulse modulation can have the effect of widening or narrowing the signal Power Spectral Density (PSD). The signal PSD characteristics can typically be predicted based upon the pulsed signal characteristics.

2.2.5 Intermittent Signal

An intermittent signal is defined as a signal whose instantaneous power intermittently drops below some defined level or threshold. These instantaneous power fluctuations are random and may be caused by atmospheric effects, multipath fading, blockage, platform attitude, antenna pointing, to name a few. Section 2.4.3 provides insight into the common ways in which signal temporal fluctuation may occur.

Analysis involving intermittent signals should not be performed by simply considering long-term properties (such as average power). Instead, analysis should consider the temporal fluctuation of signal properties and include the effects of those fluctuations in the analysis.

2.3 LINK BUDGET ANALYSIS

A basic *link budget analysis* technique assumes that a communications link can be modeled as a series of independent modules originating at the transmitter and terminating at the receiver input. Each module is represented by its output power, gain, or loss. Link budget analysis determines the effect of each module on the desired or undesired signal power at the receiver input, without tracing a signal through the various components within the receiver. If the analysis shows the signal power to be too low for a given link, then more power must be budgeted or allocated for that receiver (e.g., by moving the antennas closer together or increasing transmitter power).

2.3.1 Link Budget Model

The most basic model is composed of a transmitter and receiver linked by a propagation channel, as shown in Figure 2.3-1. The transmitter signal is represented by the transmitted power, which is delivered to the propagation channel. The channel subjects the signal to propagation loss, which is a reduction in power of the transmitted signal. The received signal is simply the transmitted signal, reduced in magnitude by the propagation loss. Figure 2.3-1 illustrates a basic model for a link budget. If there are multiple transmitters (a desired transmitter and one or more interfering transmitters), then the model in Figure 2.3-1 is used for each transmitter. For the desired transmitter, it yields the desired signal power at the receiver input. For an interfering transmitter, it yields the interfering signal power at the receiver input.

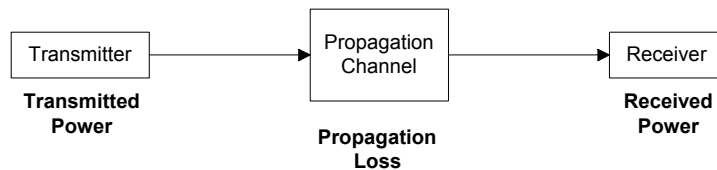

Figure 2.3-1. Basic Link Budget Model

The basic model of Figure 2.3-1 assumes that antennas are embedded in the transmitter and receiver modules. If antenna effects need to be considered separately they can be added to the model as shown in Figure 2.3-2.

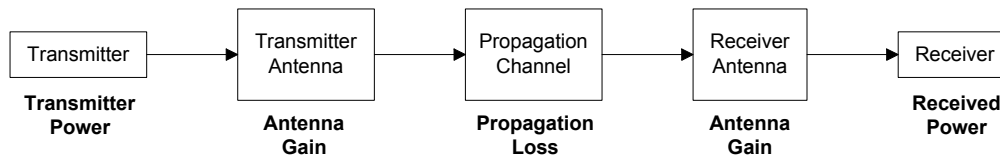

Figure 2.3-2. More Detailed Link Budget Model

Transmitter - The only transmitter characteristic considered is the transmitter output power P_T , which is typically expressed in decibels referenced to power units, such as decibels relative to one milliwatt (dBm) or decibels relative to one watt (dBW).

Transmitter Antenna - The effect of the transmitter antenna is expressed as a power gain G_T with respect to an isotropic antenna, expressed in units of dBi. Antennas radiate in all directions, but many antennas are designed to favor one or more particular directions. For these directional antennas, the gain will depend on the orientation of the antenna with respect to the propagation path.

An antenna pattern, which shows the gain in all directions, may be used to determine the gain for a particular link. Antenna patterns usually describe the far-field radiation pattern.

Effective Isotropic Radiated Power (EIRP) - This quantity combines the transmitter power with the transmitter antenna gain and is often used for convenience or to simplify the analysis. If the antenna is directional, the EIRP will be valid only in the direction corresponding to the antenna gain that was used in determining the EIRP. The unit of EIRP is the same as for the transmitter power: dBm, dBW, etc. Specific to land-mobile use, the term Effective Radiated Power (ERP) is the maximum radiated power in any one direction relative to an isotropic antenna.

Propagation Loss - Equation 2-1 shows the relationship between the received signal power and the transmitted signal power. Propagation loss is expressed as the ratio of the transmitted power to the received power assuming unity transmit and receive antenna gains and no RF passive losses. Since this ratio is always greater than 1, the propagation loss in dB will always be a positive quantity.

Receiver Antenna - The gain G_R of the receiver antenna with respect to an isotropic antenna is expressed in dBi. The same considerations of directionality that applied to the transmitter antenna also apply to the receiver antenna.

2.3.2 Link Budget Equation

A typical application of the link budget concept is the calculation of the received signal power for a line-of-sight (LOS) communications link:

$$S = P_T + G_T + G_R - L_P - L_T - L_R \quad (2-1)$$

where

S	=	signal power at receiver input (note: receiver input is referenced at the Low Noise Amplifier (LNA) input), in dBm
P _T	=	signal power at transmitter output, dBm
L _T	=	transmit system RF passive losses (between transmitter and antenna, e.g., cable insertion loss), dB
G _T	=	transmitter antenna gain, dBi
L _P	=	propagation loss, dB
G _R	=	receiver antenna gain, dBi
L _R	=	receive system RF passive losses (between antenna and receiver, e.g., coupler loss, cable loss), dB

Propagation loss is the total path loss between transmitter and receiver antennas and includes free space and other relevant propagation factors, such as terrain effects. The free-space loss component L_{fs} of the propagation loss can be derived from Friis' Transmission formula³ and it is determined by

$$L_{fs} = 20 (\log_{10} f + \log_{10} d) + 32.45 \text{ dB} \quad (2-2)$$

³ H. T. Friis. *A Note on a Simple Transmission Formula*, Proc. IRE. pp. 254-256. May 1946.

where

d = distance between antennas, in kilometers

f = transmitter frequency, in MHz

Propagation loss components other than simple free space loss are described in Section 2.4.3.2.

If the EIRP is specified instead of the transmitter power, then the following relationship is used:

$$EIRP = P_T + G_T - L_T \quad (2-3)$$

Equation 2-1 can be used to compute the desired signal power at the receiver input as well as the undesired signal power at the receiver input. In using Equation 2-1 to compute the power of an undesired signal, it is important to consider the antenna gain that is appropriate to the specific geometry of the interference event.

While the above model covers the fundamentals of link budget analysis, there are many other factors which must typically be considered when performing a link analysis. These factors include clear-sky atmospheric loss, rain loss or rain fade margin (for a given link availability), polarization loss, antenna pointing error loss, radome loss (dry and wet), sky-noise degradation (dependent on rain fade, frequency, elevation, etc.), multipath and other propagation-related losses, blockage loss (e.g., building penetration loss, body loss, aircraft wing, etc.), cross-polarization degradation, intermodulation distortion degradation, and system / equipment implementation imperfections such as beam forming loss, FEC Coder-Decoder (CODEC) and Modulator-Demodulator (MODEM) implementation losses. Some or all of these factors may be applicable for a specific analysis scenario.

2.3.3 Link Budget Performance Measures

Link budget analysis can be used to determine desired and undesired signal power levels at the receiver input. From this data, predictions of receiver performance can be formulated. For example, aggregate input signal power can be compared to receiver performance specifications to determine whether the input signal power falls within the range for which the receiver meets performance specifications. Additionally, aggregate undesired signal power density at the receiver input can be compared to the receiver noise density to determine whether the interferer desensitizes the receiver. These concepts and analyses are elaborated upon in the discussion below.

If the aggregate signal power at the receiver input exceeds a particular threshold, the receiver may introduce undesired nonlinear effects and fail to provide the desired gain. These nonlinear effects typically emerge in the receiver Low Noise Amplifier (LNA), however, they may occur in downstream components such as a downconverter or a fiber optic transport system. The net effect of these undesired nonlinear effects may be degradation to the receiver figure of merit identified as Gain-to-Noise Temperature ratio (G/T). Receive system G/T is described in further detail in Section 2.3.6.

Conversely, the desired signal power at the receiver must exceed the minimum input power which can be discerned by the receiver. The fact that a signal is strong enough to be discerned or detected, however, does not imply that it is strong enough for the message to be accurately recovered.

A more useful specification for relating receiver input signal power to performance is receiver sensitivity. This is the minimum received signal level required to produce a certain receiver output of some minimum required signal quality. The minimal required signal quality may be defined as a

particular value of BER or a signal-to-noise ratio (S/N). This relationship between receiver performance and input signal power is only applicable when interference is not present. When interference is present, link budget analysis can be used to determine the S/I or the Carrier-to-Interference power ratio (C/I) at the input to the receiver (note: C/I is the same as S/I except the S/I term is usually used with analog systems and the C/I term is used with digital systems – see Section 2.3.5). From this ratio and knowledge of the desired and undesired signal characteristics, receiver performance predictions of varying accuracy can be made. For example, if the interference characteristics are such that the interferer is continuous and broadband relative to the desired signal, a very accurate estimate of BER performance can be formulated by simply adjusting the receiver noise density based on the interference noise density.

For many interference scenarios, however, simply knowing the S/I (or C/I) at the receiver input and the characteristics of the desired and undesired signals is not sufficient to predict receiver performance. Knowledge of the receiver signal processing and interference rejection is needed. An objective of this Handbook is to provide the analyst with the knowledge and understanding of communications system receiver design and operation such that performance analysis can be performed for interference scenarios beyond the simplified continuous broadband interferer scenario.

2.3.4 Limitations of Link Budget Analysis

The simple link budget analysis technique is often used to obtain a useful estimate, however, it is based on several assumptions which may limit its accuracy.

It is assumed that average power provides a realistic and meaningful characterization of the input signal. This is valid if each of the independent variables in the analysis (e.g., the independent variables in Equation 2-1) are constant in time. Many systems, however, do exhibit time variation of one or more of these variables. These variations can be modeled, however, software tools are typically required to accomplish this task.

Equation 2-1 includes propagation loss, however, the only component of propagation loss which is typically known is the free-space propagation loss. The full propagation loss calculation for many practical systems requires the availability of sophisticated propagation models. Common propagation models are available in a variety of software tools and such tools must typically be used when there is a desire to go beyond the simple free-space loss case. Section 2.4.3.2 provides additional insight into propagation effects and the various propagation models available to the analyst.

2.3.5 Relationship between Link Budget and Interference Protection Criteria

Receivers may be protected from harmful interference via national and international organization rules and regulations. Such rules and regulations typically use a small set of interference metrics referenced at the input to the receiver to define a maximum level of interference one service may impose on another. Common interference metrics would include the following:

S/I	=	desired signal power to interference power ratio
C/I	=	desired modulated carrier power to interference power ratio; same as S/I except S/I is typically used with analog systems and C/I is used with digital systems
I/N	=	Interference power to receiver system noise power ratio
I_o/N_o	=	Interference power density to receiver system noise power density

Since these metrics are referenced at the input to the receiver, link budget analysis can be used to compute the ratios for a particular system or application. Section 2.3.6 provides a detailed description of receiver system noise temperature and receiver system noise power density calculations.

The above metrics can be used to constrain individual interferer levels and to constrain aggregate interference levels. Since interferers are almost always uncorrelated with each other, aggregate interference levels can be computed by algebraically summing the individual interferer power levels (in non-dB).

National radio communication rulemaking bodies which establish the interference metric thresholds for the various frequency bands and services include the NTIA and the Federal Communications Commission (FCC). The corresponding international rulemaking body is the International Telecommunication Union (ITU). Appendix A is provided to give insight into the use of interference metric thresholds to constrain interference levels.

2.3.6 Receiver Noise Temperature Calculations

One receive system figure of merit is G/T. This section describes G/T, explains how system temperature is computed and examines how the system temperature value changes with reference point.

Although the system G/T is independent of the reference point, it is important to clearly define the reference point when calculating the system gain or the system temperature. Their ratio will be constant however their values will depend on the reference point. In this Handbook, the chosen reference point is at the receiver input. This is shown in Figure 2.3-3.

System noise temperature includes noise contributions from the antenna, RF passive losses, and the receiver. Let T_e be the effective receive system noise temperature at the chosen reference point (in this case at the receiver input as illustrated in Figure 2.3-3).

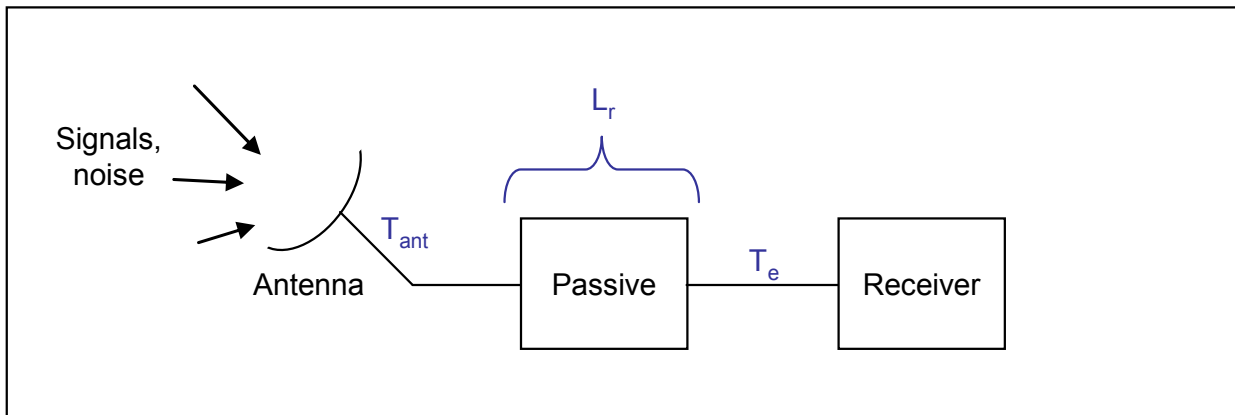

Figure 2.3-3. System Temperature Model

Effective system noise temperature (T_e) referenced to the receiver input can be obtained from

$$T_e = \frac{T_{ant}}{L_r} + \frac{(L_r - 1)}{L_r} T_0 + T_r \quad (2-4)$$

where

- T_{ant} = antenna noise temperature (depends on frequency, elevation angle, sky noise temperature, and rain as shown in Equation 2-14), degrees Kelvin
- L_r = transmission line loss between antenna and receiver input expressed as a power ratio (not in dB)
- T_o = ambient temperature, Kelvin (290°K)
- T_r = receiver noise temperature at receiver input, Kelvin

The first term of Equation 2-4 T_{ant} / L_r is the antenna noise temperature referenced to the input of the receiver, hence the antenna temperature is reduced by the transmission line attenuation (L_r). The second term $[(L_r - 1)T_o / L_r]$ is the noise temperature of the transmission line also referenced to the input of the receiver. The last term T_r is the receiver noise temperature which characterizes the receiver noise performance.

The receiver noise performance is typically represented by its Noise Figure (NF) in dB. The receiver NF is related to the receiver noise factor (F_r) by

$$NF_r = 10 \log(F_r) \quad (2-5)$$

where F_r is defined as the ratio of the S/N at the input to the device $(S/N)_{in}$ to the S/N at the output of the device $(S/N)_{out}$.

The relationship between the receiver noise temperature (T_r) and F_r is

$$T_r = T_o(F_r - 1) \quad (2-6)$$

In low noise applications a LNA is typically the first component in the receiving equipment chain. Its NF or noise temperature is usually well known and readily available for use in a system temperature analysis. When the receiver LNA gain is high and its NF is low then the noise contributions of the subsequent downstream receiver components will be negligible, and the receiver NF can thus be approximated by the LNA NF. The noise power density (N_o) (in W/Hz) can be obtained from T_e using Equation 2-7.

$$N_o = k T_e \quad \text{W/Hz} \quad (2-7)$$

where

- k = Boltzman's constant (1.38×10^{-23} J/K)

The system gain (G) referenced to the receiver input is

$$G = \frac{G_A}{L_r} \quad (2-8)$$

From Equations 2-4, 2-6, and 2-8 the system G/T is computed as

$$G/T = \frac{G_A}{T_{ant} + T_o(L_r F_r - 1)} \quad (2-9)$$

If the G/T reference point is chosen to be just after the antenna flange, the effective system noise temperature at this reference point (T_{ea}) can be expressed as

$$T_{ea} = L_r T_e \quad (2-10)$$

Thus, from Equations 2-4, 2-6, and 2-10, it follows that

$$T_{ea} = T_{ant} + T_o (L_r F_r - 1) \quad (2-11)$$

Comparing Equation 2-6 with Equation 2-11 it can be said that the effective receiver noise figure referenced to the antenna flange (before the line loss) is $L_r F_r$.

The system gain at the antenna flange is simply the antenna gain (G). Dividing the antenna gain G by Equation 2-11 leads to the same G/T result from Equation 2-9 demonstrating that the G/T is independent of the reference point selected.

The antenna noise temperature (T_{ant}) is a measure that describes the noise power received by the antenna at a given frequency. Antenna noise temperature depends on:

- Antenna radiation pattern
- Antenna elevation angle
- Frequency
- Sky noise (due to atmosphere, precipitation, solar, cosmic, galactic sources)
- Environmental noise (includes man-made)
- Ground noise

Clear-sky Clear-sky noise temperatures as a function of frequency and elevation angle are available from ITU curves or from science literature.⁴ The noise temperature contributions from the other sources will need to be added to this clear sky noise temperature. For low elevation angles the ground noise will be mostly thermal radiation emanating from the surrounding terrain which will be picked up by the antenna sidelobes. Rain will also increase the antenna noise temperature. To estimate the total antenna noise temperature due to ground noise and rain we separate the antenna noise into two components, the antenna noise in clear-sky conditions (T_A) and the antenna noise temperature contribution caused by rain (ΔT_A).

$$T_{ant} = T_A + \Delta T_A \quad (2-12)$$

The antenna noise temperature in clear-sky conditions has two components, the clear-sky noise temperature (T_{sky}) and the antenna noise temperature due to ground noise (T_g).

$$T_A = T_{sky} + T_g \quad (2-13)$$

where

- T_{sky} = antenna noise temperature due to clear sky, Kelvin
 T_g = antenna noise temperature due to ground, Kelvin

⁴ NASA JPL. *Link Analysis of a Telecommunication System on Earth, in Geostationary Orbit, and at the Moon: Atmospheric Attenuation and Noise Temperature Effects. Interplanetary Network Progress Report 42-168. 15 February 2007.*

The antenna noise temperature contribution due to rain ΔT_A is fairly accurately represented by the formula:⁵

$$\Delta T_A = \frac{L_{rain} - 1}{L_{rain}} (T_{atm} - T_{sky}) \quad (2-14)$$

where

T_{atm} = physical temperature of atmosphere as seen by the receiving antenna (approximately 270 K)

L_{rain} = losses due to precipitation (rain)

L_{rain} = $10^{A/10}$ where A is rain fade in dB ($L_{rain} \geq 1$)

From Equations 2-12, 2-13, and 2-14, it then follows that

$$T_{ant} = \frac{L_{rain} - 1}{L_{rain}} (T_{atm} - T_{sky}) + [T_{sky} + T_g] \quad (2-15)$$

2.4 RECEIVER PERFORMANCE ANALYSIS

In contrast to the link-budget analysis, a system performance analysis directly addresses the performance of the receiver. The system performance model is divided into three parts: the transmitter model, the RF channel model, and the receiver performance model. This section presents the methodology for performing an analysis with the receiver performance model.

2.4.1 System Performance Model

The system performance model is shown in Figure 2.4-1. The transmitter and receiver are modeled as systems composed of a number of modules. These modules – or functional blocks – represent distinct signal-processing operations. The transmitter modules systematically prepare the information signal for propagation through the RF channel. The receiver essentially reverses the operations performed by the transmitter to obtain the information. The antennas have been included in the RF channel which, in addition, contains an interference source. The interference propagates through its own RF channel. The interference RF channel is not shown in the illustration.

⁵ ITU-R Recommendations S.733-2 and P.372-8.

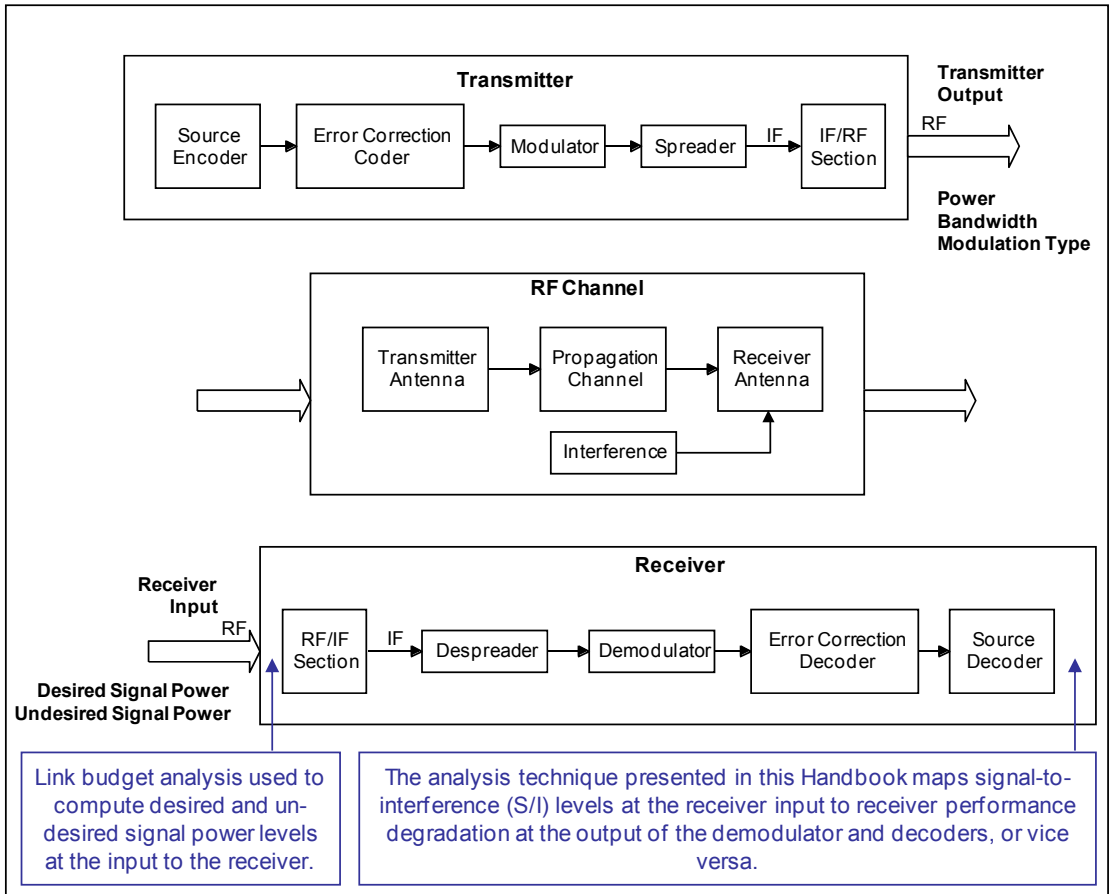

Figure 2.4-1. System Performance Model

One benefit of placing the antenna models in the RF channel model is that the effects of site location are grouped together. These effects include antenna orientation, separation distances, and environmental phenomena such as atmospheric absorption and ground conductivity. This organization permits analysts who specialize in RF propagation to focus on that part of the communication link. The communications system model in Figure 2.4-1 has proven to be a very practical and useful representation.

2.4.1.1 Transmitter

As modeled, the transmitter has five modules. Not all transmitters will have all five modules. For example, the transmitter of a purely analog system has only two modules: the RF/IF section and the modulator.

Source Encoder. The source encoder converts the source into a sequence of bits at a certain data rate. If the source is analog, an analog-to-digital converter (ADC) samples and encodes the analog waveform. If the source is digital, the source encoder reformats and retimes the input data if necessary. The output of the source encoder is a sequence of information bits, at the information data rate.

FEC Encoder. The FEC encoder encodes the data from the source encoder to meet requirements dictated by the communication channel. The FEC encoder adds code bits to the information bit sequence. In many cases, this requires that the data rate be increased to accommodate the extra bits. The output of the FEC encoder is a sequence of code bits, at the coded data rate.

Modulator. The modulator creates an analog waveform (carrier) whose properties vary in accordance with the input waveform or bit sequence. The amplitude, frequency, and phase of the carrier may be modified by the modulation process. There are a great many modulation schemes. The output of the modulator is a modulated carrier waveform. The frequency of this waveform is usually not suitable for RF transmission, and will have to be changed (usually increased) in subsequent processing.

Spreader. The digital modulator output waveform will have a bandwidth that is a function of the coded data rate and the modulation type. The spreader creates a so-called “spread-spectrum” signal, which increases this bandwidth. There are two common approaches to spectrum spreading. Frequency-hopping utilizes a number of different carrier frequencies rather than just one. These carriers span a frequency range that is much larger than if a single carrier were used. Direct sequence (DS) converts the input data rate to a much higher output data rate. The resulting waveform has a much larger bandwidth than if the lower data rate were used.

It is to be understood that separating the spreader from the modulator may not be representative of actual equipment, however, for the purposes of describing the transmitter in terms of fundamental functional blocks, this approach is chosen.

RF/IF Section. The RF/IF section provides frequency translation, filtering, and amplification to prepare the signal for transmission. The output of this section is delivered to the transmitter antenna by a cable, waveguide, or some other conductor.

2.4.1.2 RF Channel

Transmitter Antenna. The transmitter antenna may be designed to focus RF energy in a particular direction for a point-to-point system, or it may be omni-directional, to support point-to-multipoint and mobile communications. The transmitter antenna adds gain (or loss) to the transmitter output.

Propagation Channel. The most basic propagation channel is free space – the transmitted signal is attenuated only according to the inverse square distance RF radiation law. A more realistic propagation channel could include the effects of natural and man-made obstructions, atmospheric effects, ground effects, and other effects. Propagation modeling can be very complex. Many models have been developed to simulate the propagation of RF energy in various environments. The use of these models is somewhat specialized, and is not covered in this Handbook. The ultimate purpose of a propagation model is to predict the magnitude (and possibly other characteristics such as phase) of the transmitted signal at the receiver location.

Interference. The interference source is typically another transmitter in the environment. To simplify Figure 2.4-1, it is shown as a single block that feeds the receiver antenna block. The actual transmitter, of course, creates a signal in its own modules and sends that signal through its antenna and through a separate propagation channel. In addition, there may be multiple interfering transmitters. If multiple interferers are present, the aggregate interference must be considered.

Receiver Antenna. The purpose of the receiver antenna is to collect sufficient energy from the transmitted signal so that the transmitted information can be extracted by the receiver system. Depending on its design and orientation, the receiver antenna may increase or decrease the received power level relative to an isotropic antenna.

2.4.1.3 Receiver

The receiver takes its input from the receiver antenna, and performs processing complementary to that done by the transmitter.

RF/IF Section. The RF/IF section converts the frequency of the received signal to an IF that is more suitable for signal processing. It also filters the composite signal to reduce the undesired signal power.

Despreader. The despreader, in the case of a frequency-hopping system, resolves the multiple-carrier input so that a single IF is obtained. In the case of a DS system, the despreader removes the spreading code from the desired signal.

As noted in the transmitter model, the despreading function is typically integrated with the demodulation function. Separating the functions here is simply for discussion purposes and should not be interpreted as being indicative of typical hardware design.

Demodulator. A digital demodulator converts the input waveform to a bit sequence. If error correction coding has been applied, this is the coded bit sequence, at the coded data rate. An analog demodulator produces a replica of the original baseband analog waveform (but with some noise, interference, and distortion).

FEC Decoder. The FEC decoder performs the digital processing necessary to reconstruct the original information bit sequence. The output is the information bit sequence, at the information bit rate. This bit sequence may contain residual errors.

Source Decoder. The source decoder converts the information bit sequence to the format required by the user of the receiver. If this format is analog, a digital-to-analog converter (DAC) will be employed at this stage. The output of the source decoder is the output of the receiver. In general, it will differ somewhat from what was transmitted due to noise and interference. This difference can be quantified, and is a measure of the overall system performance.

2.4.2 System Performance Measures

The goal of an RF analysis is to quantitatively predict the performance of a system. The performance prediction can then be compared to certain performance objectives to obtain an assessment of the system operation. There are several useful measures of performance.

2.4.2.1 Signal-to-Noise Ratio

The S/N is calculated by determining the desired-signal power S and the noise power N at some point in the system. The S/N is expressed in dB. Depending on the system and the application, target performance goals for S/N might range from 5 dB to 30 dB. If noise-like interference is present, then the variable N may be used to represent the sum of the interference power and the noise power (added in non-logarithmic units such as mW).

2.4.2.2 Signal-to-Interference Ratio

The S/I is calculated when there is an undesired signal which cannot be adequately modeled as additional noise. For example, in addition to thermal noise there may also be a CW interfering signal.

2.4.2.3 Bit Error Rate and Symbol Error Rate

Figure 2.4-2 shows the reference points in a communications transmission model where uncoded Bit Rate (R_b), coded Bit Rate or Symbol Rate (R_s) and modulation symbol rate or baud rate (R_{baud}) are defined. Error rate of coded symbols is referred to as Symbol Error Rate (SER).

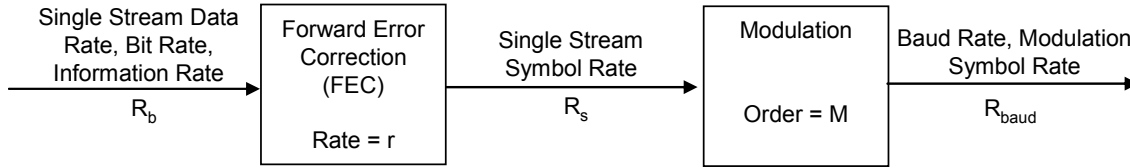

Figure 2.4-2. Transmission Signaling Model and Definitions

The BER, which only applies to digital systems, can be understood in different ways. It is the probability of a particular bit being wrong, and it is also the ratio of bit errors to total bits received in the long term. The latter interpretation is useful when the error-causing process is constant over the analysis interval. The target BER after error correction is often orders of magnitude better than 10^{-6} .

2.4.2.4 Subjective Performance Measures

Measures of signal power or BER do not directly address the quality of communication as perceived by users of the system. Some subjective performance measures have been defined that do address that quality of communication. For voice communications, the articulation score (AS) is defined as the percentage of words, phrases, sentences, or other message elements correctly identified by a listener panel. The Television Allocation Study Organization (TASO) score is a similar evaluation of television picture quality by a viewer panel. The articulation index (AI) is a calculated quantity that is designed to be a predictor of voice intelligibility.

It is possible to establish a correspondence between objective performance and subjective performance by extensive, careful testing and polling. It is very difficult, however, to extrapolate subjective test results beyond the parameter set used for the tests.

2.4.2.5 Time-varying Performance

When reporting results in terms of S/N or BER, it may be assumed that these quantities are relatively constant. This implies, of course, that the phenomena responsible for these measures of performance are relatively constant. If this is not the case, then the temporal variations should be taken into account. These variations are often expressed statistically. For example, a quality-of-service (QoS) target might be a BER of better than 10^{-5} at least 90% of the time, and a BER worse than 10^{-3} no more than 1% of the time.

2.4.3 System Performance Analysis Limitations

In Section 2.3.4, the limitations of a link budget analysis (exclusion of systems with temporal variations, unsophisticated propagation model, no detailed receiver model) were presented. The first two of those limitations are still concerns in a system performance analysis. A system performance analysis does have detailed receiver modeling, but some effects occur within a receiver that are not included; namely, the nonlinear effects that occur when an interfering signal is very strong.

2.4.3.1 Temporal Variations

The analysis techniques and transfer functions presented in the Handbook are useful for systems in which random temporal variations are not present. In particular, fading and fade-related outages are not addressed by the analysis technique.

Fading. The term *fading* applies to unexpectedly large variations in the desired signal power at the receiver. The cause of the variation may be understood, but may be impractical to model. For example, fading may be caused by multipath interference in mobile communications. Small changes in position can result in large changes in the way the signal replicas combine at the receiver, leading to occasional periods of weak reception known as *fades*.

Fading may be accounted for very simply by specifying a *fade margin*, which is an increase in the magnitude of received-signal power that is required for proper system operation. The size of the fade margin may be determined experimentally by field measurement, or may be based on experiences with similar systems in similar environments.

Outages. An *outage* is a period of time during which system operation is so compromised that for all practical purposes it does not work at all. It is therefore not helpful to attempt to quantify receiver performance during an outage. Instead, the process responsible for the outage should be analyzed, and the effects on the system should be modeled statistically. An outage may be a single, catastrophic event, such as a lightning strike. In this case, a typical performance measure is simply the probability of occurrence.

2.4.3.2 Complex RF Propagation Environments

Free-space propagation loss is a simple and convenient way to compute path loss. Unfortunately, it fails to account for environment effects including terrain, foliage, and buildings. These obstructions affect propagation by blocking, diffracting, absorbing, scattering, and reflecting RF energy. The atmosphere also affects propagation through refraction, absorption, ducting, and scattering. These environmental effects are frequency dependent and, in some cases, intermittent in nature. Nevertheless, loss from propagation is usually the largest factor in the link budget – by many orders of magnitude.

There are many analytical and simulation-based RF propagation models available. Table 2.4-1 provides a summary of several common RF propagation models. For further information on RF propagation models and their respective strengths and limitations, please consult relevant NTIA documentation.

Table 2.4-1. Summary of Widely Used Propagation Models

Model	Frequency Range (MHz)
Terrain Based Models	
Terrain Integrated Rough Earth Model	1 – 20000
Irregular Terrain Model	20 – 20000
Tropospheric Electromagnetic Parabolic Equation Routine	2 – 40000
Advanced Propagation Model	2 – 40000
Smooth Earth Models	
SEM (Spherical Earth Model)	1 – 20000
Damboldt	2 – 50
Terrain and Morphology Models	
Hybrid (COST-231 – Walfisch – Ikegami)	100 – 5000
Okumura – Hata – COST-231 – ITU	100 – 2000
Terrain and Building Models	
Vertical Plane Launch	400 – 20000
Ray Tracing Model	400 – 20000

2.4.3.3 Collocated RF Equipment

A cosite environment is one in which interference power levels are so high that nonlinear effects such as desensitization and intermodulation must be considered. The interfering signal power level may be high because the transmitter and receiver antennas are close together (collocated). A typical cosite environment is a platform such as a ship, airplane, or tower on which multiple antennas are located.

As an example, consider the case in which a strong interfering signal is far off-tune from the receiver frequency. Because it is far off-tune, it is attenuated so much by the receiver filters that the residual signal has no effect on the receiver. However, before it enters those filters it passes through the RF amplifier (the LNA). If its power is outside of the intended (linear) operating range of the amplifier, it will generally desensitize the amplifier; that is, reduce the amplifier gain. This, in turn, reduces amplification of the desired signal power so that the desired signal gets lost in the noise. Thus, the positive effects of filtering have been defeated by the nonlinear effect.

Cosite effects are not included in this Handbook. For cases in which filtering plays a significant role in determining an interference threshold, the analyst should ensure that the signal power is sufficiently low that nonlinear effects will not occur. If nonlinear effects are possible, cosite analysis techniques should be applied to adjust the frequency and/or power level of the interfering signal that is input to the RF/IF section.

2.4.4 Receiver Performance Analysis Types

There are generally three techniques – analytical, measurement, and simulation – that can be used to assess the performance of a receiver.

In the *analytical* technique, the operations of receiver modules are represented by equations that can be solved in closed form or by numerical methods. Many of the transfer functions in the Handbook were obtained analytically.

In the *measurement* technique, receiver equipment is acquired and subjected to laboratory measurement. This technique is useful for investigating the performance of specific hardware, but it is lacking in generality. Measurement was not used directly in developing the receiver transfer

functions or the performance degradation data, but some of the results have been confirmed by measurement.

In the *simulation* technique, software generates samples of the signal waveforms and processes these samples through the simulated receiver components. Simulated measurement devices then determine performance measures such as BER. Software simulation of RF systems is useful for systems that are too difficult to characterize analytically. Simulation permits a fine degree of control over system parameters. Many of the results in the Handbook were obtained by simulation.

These techniques can be combined. For example, measurement data for a functional block can be entered into a simulation. A hardware module can even be used directly as a functional block in a simulation system. This technique may be used to test specific modules in the controlled, repeatable environment that a simulation system provides.

2.4.5 Receiver Performance Analysis Steps

A receiver performance analysis is that part of the system performance analysis that focuses on processing within the receiver. The communications receiver model is shown in Figure 2.4-3 which has been extracted from Figure 2.4-1. Each processing block is represented by a transfer function that expresses the output of the block in terms of the input.

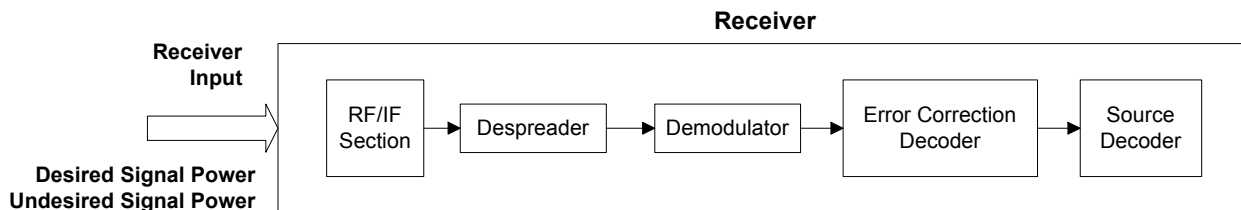

Figure 2.4-3. Receiver Performance Model

In one common situation, the value of the required performance measure for the receiver is known and the objective is to determine the corresponding input power ratios (e.g., S/N and S/I). In this case, the analyst steps through the modules in Figure 2.4-3 in right-to-left order, although part of the RF/IF calculation must be done first.

In some situations, the receiver characteristics are not sufficiently known by the analyst or the receiver signal processing is of a complexity that a module-by-module analysis is not practical. Additionally, realistic interference scenarios are such that they can so encumber the analyst with mathematics that the module-by-module analysis approach is not feasible. For this reason, the Handbook provides a toolbox of analysis methods and a broad catalog of performance degradation data to facilitate communications systems performance degradation assessments.

Table 2.4-2 provides an overview of the performance degradation analysis methods described in this Handbook. In effect, Table 2.4-2 provides the step-by-step instructions on how to use this Handbook. The techniques presented range from the simple (e.g., the simple Additive White Gaussian Noise (AWGN) analysis approach) to the detailed (e.g., the traditional receiver performance analysis). Of particular note is that a catalog look-up approach is presented which greatly reduces the analysis burden levied on the analyst but still yields reliable results. It is also noteworthy that execution of the Communications Receiver Performance Degradation Handbook simulation models by a knowledgeable operator can produce the performance degradation results necessary to complete an analysis.

Table 2.4-2. Receiver Performance Degradation Analysis Approaches

Analysis Approach	Criteria For Use	Approach
Simple AWGN	<ul style="list-style-type: none"> • Interference is unambiguously AWGN-like at the input to the demodulator • Interference is unambiguously AWGN-like at the input to the bit / symbol synchronizer (e.g., any interferer after receiver Pseudorandom Noise (PN) chip correlation / despreading) • Other instances based upon the RF analyst's discretion • Not applicable for pulsed interference scenarios 	<p>Step 1: Determine C/I at the input to the receiver (use link budget analysis described in Section 2.3)</p> <p>Step 2: Compute C/I at the input to the demodulator as follows:</p> $\left(\frac{C}{I}\right)_{\text{demod}} = \left(\frac{C}{I}\right)_{\text{rcvr}} + FDR$ <p>Where:</p> <ul style="list-style-type: none"> •FDR = Frequency Dependent Rejection as defined in Section 3.2 •Parameters are in dB <p>Step 3: Compute the receiver performance degradation as follows:</p> $\Delta \frac{C}{N} = 10 \log \left(\frac{1}{1 + \frac{(C/N)}{(C/I)}} \right) \text{ dB}$ <p>Where:</p> <ul style="list-style-type: none"> •Parameters and computations are in non-dB terms •C/N and C/I are referenced to the input of the demodulator •$\Delta C/N$ is the additional power a transmitter must provide to overcome the effects of the interference <p>Note: BER vs. E_b/N_0 performance degradation curves of the variety presented in this Handbook can be analytically generated for the simple AWGN-like interference scenario as follows:</p>
Simple Intermittent / Pulsed Interference	<ul style="list-style-type: none"> • If the receiver is only affected by the interference when the interference falls in the victim receiver band (e.g., a frequency-hopping receiver or interferer) • Pulsed interference pulse duration is >> desired signal modulation symbol duration (such that receiver RF/IF filtering does not appreciably effect the characteristics of the interferer) 	$BER = P_{\text{off}} \cdot BER_N + P_{\text{on}} \cdot BER_{I+N}$ <ul style="list-style-type: none"> • P_{off} = probability of interferer off or pulse off • P_{on} = probability of interferer on or pulse on • BER_N = BER in the presence of noise only • BER_{I+N} = BER in the presence of noise and interference
Catalog Look-up (w/o FDR knowledge)	<ul style="list-style-type: none"> • Insight into the communications receiver composition and design is <u>not</u> possible • Communications system scenario and interference scenario align within reason to a scenario for 	<p>Step 1: Compute the C/I at the receiver input for the interference scenario under study (use link budget analysis described in Section 2.3)</p> <p>Step 2: Review Sections 5 through 8 of this Handbook to identify the performance data curves for which the communications scenario closely aligns (or most closely aligns) to the communications system scenario under study (i.e., identify the correct modulation and coding curves)</p> <p>Step 3: Considering the curves identified in Step 2, identify the curves</p>

Analysis Approach	Criteria For Use	Approach
	<p>which the Handbook presents performance data</p> <ul style="list-style-type: none"> • Communications system scenario and interference scenario for which the Handbook presents performance data can be scaled to align to the communications system and interference scenario under study • General trend estimation of performance degradation is acceptable 	<p>for which the interference scenario closely aligns (or most closely aligns) to the interference scenario under study</p> <p>Step 4: Considering the curves identified in Step 3, identify the curve which most closely aligns to the C/I computed in Step 1</p> <p>Step 5: Estimate performance degradation based upon the delta between the no interference performance curve and the applicable C/I curve identified in Step 4; or use the two curves to identify parameters which enable achievement of the protection criteria applicable to the evaluation scenario</p> <p>Note: This approach has true merit as the performance degradation curves presented in this Handbook are based upon receiver design characteristics fundamental across the communications industry. In particular, the data detection process is consistent with that used in typical communications equipment. Since the data detection filter is invariably the most narrow filter (more narrow than the RF/IF filtering), it ultimately defines the FDR up to the point where a decision is made on the data bit.</p>
<p>Catalog Look-up (w/ FDR knowledge)</p>	<ul style="list-style-type: none"> • Insight into the communications receiver composition and design <u>is</u> possible • Communications system scenario and interference scenario align within reason to a scenario for which the Handbook presents performance data • Communications system scenario and interference scenario for which the Handbook presents performance data can be scaled to align to the communications system and interference scenario under study • General trend estimation of performance degradation is acceptable 	<p>Step 1: Compute the C/I at the receiver input for the interference scenario under study (use link budget analysis described in Section 2.3)</p> <p>Step 2: Compute the C/I at the demodulator input for the communications and interference under study (use the FDR technique introduced earlier in this table)</p> <p>Step 3: Review Sections 5 through 8 of this Handbook to identify the performance data curves for which the communications scenario closely aligns (or most closely aligns) to the communications system scenario under study (i.e., identify the correct modulation and coding curves)</p> <p>Step 4: Considering the curves identified in Step 3, identify the curves for which the interference scenario closely aligns (or most closely aligns) to the interference scenario under study</p> <p>Step 5: Re-label the C/I levels on the curves identified in Step 4 to be based upon a reference point of demodulator input (i.e., add the FDR value stated on the plot to the C/I levels stated on the plot)</p> <p>Step 6: Considering the curves established in Step 5, identify the curve which most closely aligns to the C/I computed in Step 2</p> <p>Step 7: Estimate performance degradation based upon the delta between the no interference performance curve and the applicable C/I curve identified in Step 6; or use the two curves to identify parameters which enable achievement of the protection criteria applicable to the evaluation scenario</p>
<p>Receiver Performance Analysis (legacy Handbook approach)</p>	<ul style="list-style-type: none"> • Catalog look-up approach cannot be used due to insufficient applicable performance degradation data 	<p>Step 1: Determine which modules in Figure 2.4-3 apply to the receiver.</p> <p>Step 2: Determine the nature of the interference at the output of the RF/IF section. Section 3 describes how this is determined.</p> <p>Step 3: If the interference is intermittent and a simple manual analysis (see Simple Intermittent / Pulsed Analysis approach defined earlier in this table) cannot be performed, stop. Section 3 suggests alternate analysis techniques for such cases.</p> <p>Step 4: Determine the performance criterion at the receiver output. Depending on the receiver, this might be a minimum AI or maximum BER value at the demodulator output, a maximum BER value at the FEC decoder output, or a minimum S/N value at the source decoder output.</p>

Analysis Approach	Criteria For Use	Approach
		<p>Step 5: If there is a source decoder, use the Input BER vs. Output S/N curves in Section 8 to determine the maximum BER at the source decoder input. The maximum BER corresponds to the minimum S/N value.</p> <p>Step 6: If there is a hard-decision FEC decoder, use the Input BER vs. Output BER curves in Section 7 to determine the maximum BER at the FEC decoder input. The maximum input BER corresponds to the maximum output BER. Then go to Step 8.</p> <p>Step 7: If there is a soft-decision FEC decoder, perform the operations described in Steps 8 and 9, except the soft-decision curves in Section 7 should be used rather than the digital demodulator curves in Section 6. The soft-decision curves incorporate both demodulator and FEC decoder effects.</p> <p>Step 8: If the interference at the output of the RF/IF section is noise-like (as determined in Step 2), determine the minimum S/N value at the demodulator input. In this case, N represents the total noise-like signal power, including receiver noise power and the interference power. Use the analog demodulator curves in Section 5 or the digital demodulator curves in Section 6.</p> <p>Step 9: If the interference at the output of the RF/IF section is not noise-like (as determined in Step 2), select a particular value of S/I and determine the corresponding minimum S/N value at the demodulator input. In this case, N represents the receiver noise power. Repeat this for several values of S/I. Use the analog demodulator curves in Section 5 or the digital demodulator curves in Section 6.</p> <p>Step 10: If there is a despreader, calculate the processing gain in dB. Section 4 describes the calculation.</p> <p>Step 11: Calculate the FDR in dB of the interference in the RF/IF section. Section 3 describes the calculation.</p> <p>Step 12: Add the processing gain from Step 9 and the FDR from Step 10 to get the total interference power loss in dB.</p> <p>Step 13: If the interference at the output of the RF/IF section is noise-like (as determined in Step 2), add the total interference power loss in dB from Step 11 to the minimum S/N value in dB from Step 7.</p> <p>Step 14: If the interference at the output of the RF/IF section is not noise-like (as determined in Step 2), add the total interference power loss in dB from Step 11 to each S/I value in dB from Step 8.</p>

2.5 POSSIBLE INTERFERENCE MITIGATION TECHNIQUES

RF communications systems will invariably experience interference. This RF interference may arise in many ways and may be expected or unexpected, intentional or unintentional, in-band or out-of-band, and so on. As such, RF communications systems are designed to reject or mitigate RF interference.

The most common technique for mitigating interference is filtering. Filtering is used in transmitters to limit out-of-band emissions which may degrade services operating in neighboring channels and is used in receive systems to reduce undesired, out-of-band signals which may drive the LNA into compression or may ultimately pass to the data decision circuitry and degrade BER performance. Examples of interference mitigation techniques are stated in Table 2.5-1. These techniques may or may not be appropriate for every situation and understanding the interference situation is important before pursuing a particular interference mitigation technique.

Table 2.5-1. Summary of Interference Mitigation Techniques

Technique Description		Discussion
Grouping	Technique	
Filter Techniques	Receive System RF Filtering	<ul style="list-style-type: none"> Attenuates out-of-band interference power prior to the LNA (protects the LNA) Example would be a diplexer or duplexer
	Receive System IF Filtering	<ul style="list-style-type: none"> Attenuates out-of-band interference power prior to demodulator (limits BER degradation) Can notch out narrowband in-band interferer Examples would be downconverter IF filtering and demodulator front-end filtering
	Receive System Data Detection (Baseband) Filter	<ul style="list-style-type: none"> Attenuates interference power prior to data decision (limits BER degradation) Examples would be an integrate-and-dump or “matched” filter
	Receive System Adaptive IF Filtering	<ul style="list-style-type: none"> Adaptively adjust IF filtering to react to the presence of interference
	Transmitter Filtering	<ul style="list-style-type: none"> If control exists over the interference source transmitter, filtering can be introduced to reduce harmful out-of-band emissions
Signal Design	Modulation Selection	<ul style="list-style-type: none"> Choose a modulation technique which is less susceptible to interference For example, digital modulation techniques are typically less sensitive to interference than analog modulation techniques or a lower order modulation like Offset Quadrature Phase-Shift Keying (OQPSK) can accommodate a higher interference density than a higher order modulation like 64-ary Quadrature Amplitude-Modulation (64QAM) If control exists over the interference source transmitter, select a transmitter modulation which is constant envelope with low sidelobes
	Coding Selection	<ul style="list-style-type: none"> Choose a coding technique which is less susceptible to the type of interference expected For example, a large block code is less sensitive to a high-powered, low duty cycle pulsed interferer than a convolutional code
	Spread Spectrum	<ul style="list-style-type: none"> A spread spectrum receiver is less sensitive to in-band narrowband interferers because it ultimately spreads this interferer over a wide bandwidth
	Interleaving	<ul style="list-style-type: none"> Interleaving distributes burst symbol errors over a wider collection of symbols – burst symbol errors are commonly caused by pulsed interferers Varieties of interleaving are available to protect all varieties of codes Examples include block interleaving, helical interleaving, periodic convolutional

Technique Description		Discussion
Grouping	Technique	
		interleaving, etc.
	Adaptive Modulation and Coding	<ul style="list-style-type: none"> Adjust the modulation order based upon the link availability offered by the interference condition
	Adaptive Data Rate	<ul style="list-style-type: none"> Adjust the data rate based upon the link availability offered by the interference condition
Antenna Techniques	Polarization Diversity	<ul style="list-style-type: none"> Under some circumstances, polarization diversity can be used to achieve up to 20 dB of attenuation to undesired signals For example, a satellite feeder link can use both horizontal polarization and vertical polarization to achieve nearly twice the throughput capacity as would be available using a single polarization
	Directional Antenna	<ul style="list-style-type: none"> Use antenna gain pattern to discriminate desired from undesired signals Example would be a parabolic antenna pointed to a geosynchronous satellite and away from nearby terrestrial interferers
	Larger Antenna Size	<ul style="list-style-type: none"> A larger antenna narrows the antenna beamwidth, thereby, enabling even greater discrimination, except for boresight events
	Smart Antennas	<ul style="list-style-type: none"> Maximize antenna gain in direction of desired signal and minimize gain in directions of undesired signals For example, phased array antenna pointing algorithms can simultaneously point with strong gain in the direction of the desired signal and adaptively null in the direction of the interferers Smart antennas are a viable co-channel interference mitigation technique Smart antennas can be used as an anti-jam technique
Geometric Planning	Station Placement	<ul style="list-style-type: none"> Spatial/Site diversity helps avoid/mitigate interference
Design Parameters	LNA Compression Point	<ul style="list-style-type: none"> Select LNA based upon consideration of expected interference characteristics
	Link Availability	<ul style="list-style-type: none"> Accommodate interference through consumption of margin which may exist in link availability budget
	Automatic Level Control (ALC) Response Time	<ul style="list-style-type: none"> Use ALC and ALC clipping circuit to limit pulsed interference from passing through receiver
Network Design	Data Frame / Packet Size	<ul style="list-style-type: none"> Select data frame / packet size based upon interference characteristics For example, short packet sizes may be desirable in a high-power, intermittent interference scenario
	Interference-Resistant Protocols	<ul style="list-style-type: none"> Massively diverse data routing greatly diminishes impact of interference on a particular link
Misc.	Frequency Reuse Plan	<ul style="list-style-type: none"> Reuse frequencies as allowed by the interference environment
	Interference Cancellation	<ul style="list-style-type: none"> Use multi-user detection to enable interference cancellation
	Diversity Combining	<ul style="list-style-type: none"> Rake receiver Use multiple transmit antennas for sending the same information Deep signal fades are not likely to be experienced simultaneously by two or more receive antennas
	Multiple Input Multiple	<ul style="list-style-type: none"> MIMO leverages spatial diversity as a means to improve the overall reliability and performance of band-limited systems. This is accomplished through the use of

Technique Description		Discussion
Grouping	Technique	
	Output (MIMO)	multiple antennas at both the transmitter and receiver providing an overall improvement in communication performance
	Adaptive Frequency Selection	<ul style="list-style-type: none"> ▪ System dynamically senses “available” spectrum and utilizes spectrum that is not in use ▪ Technology inherently is an interference mitigation technique
	Software-Defined Radio (SDR) / Cognitive Radio (CR)	<ul style="list-style-type: none"> ▪ SDR refers to a radio in which some or all of the physical layer functions are software defined. ▪ CR is a radio in which communication systems are aware of their environment, internal state, and location and can make decisions about operating behavior based on that information

SECTION 3 - RF/IF SECTION

This section describes the RF/IF section of a receiver and the model that represents it. It presents the FDR concept and shows how the FDR can be calculated. Then it specifies changes in the interfering signal waveform that may be caused by the RF/IF section. Finally, for cases involving intermittent interference that are beyond the scope of this Handbook, it briefly describes the types of analysis that might be required.

3.1 DESCRIPTION

The RF/IF section of a receiver is the first part of the receiver through which a signal from the antenna passes. It generally has amplifiers, mixers, filters, and perhaps other components such as automatic gain control circuits. The numbers of each component type and their specific characteristics vary from one receiver to another. A receiver performance analysis usually focuses on the amplifiers, mixers, and filters.

Typically, there are several amplifiers in the RF/IF section. Each amplifies the total composite signal at its input – including the desired, interfering, and noise components. Because the desired and interfering signals experience the same gain in an amplifier, the S/I does not change. However, the RF/IF amplifiers are the primary source of receiver noise. The noise from these amplifiers passes through all subsequent amplifiers and filters in the RF/IF section. The power of the resultant noise signal is referenced to the receiver input, which is equivalent to pretending that the noise signal enters the receiver from the antenna and experiences the full gain of all the RF/IF amplifiers. When the composite signal (including receiver noise) passes through the RF/IF amplifiers, the output S/N depends on the effective noise figure of the cascaded RF/IF components (mixer, filtering, and amplifiers). Section 2.3.6 presented a detailed description of calculating system noise temperature and noise power density. A typical noise power calculation is also presented in an example in Section 9.2.7.

Interference can degrade communication receiver performance in various ways. These include LNA compression, degraded carrier/symbol/frame synchronization, reduced (effectively) S/N or increased BER. In deep-space networks, for example, when the synchronization loops lose lock due to interference, ranging measurements are also disrupted. Impact of interference to carrier, symbol and frame synchronization in various types of wireless networks requires employment of appropriate mitigation techniques such as those in Section 2.5 as well as optimization of the system design. The LNAs are normally designed for linear operation. The 1-dB gain compression point of an LNA transfer curve is the usual measure of the smallest input power (which can be interference power) that causes a significant amount of nonlinear behavior (through compression) in an amplifier intended for linear operation. If a strong interferer is present in addition to the desired signal, the LNA can exhibit nonlinear behavior. Such behavior includes the creation of intermodulation products between the desired signal and the interferer. Thus, if a very strong interfering signal enters a receiver amplifier, it may cause nonlinear effects such as desensitization to occur (Section 2.4.3.3). This may happen, for example, when the interfering transmitter antenna is close to the receiving antenna and there is very little propagation loss to reduce the interfering signal strength. Nonlinear effects occur primarily in the RF/IF section. These effects are beyond the scope of this Handbook. It is assumed that the interfering signal power is sufficiently low that nonlinear effects are negligible.

The receiver may be tuned to various frequencies so the input signal frequency is not fixed. The mixers convert that tunable frequency to a fixed frequency. This conversion typically occurs in two

or three stages, with a different frequency employed at each stage. The mixer also converts the carrier frequency of the interfering signal in the same way. The frequency separation between the desired and interfering signals is not changed by the mixing process. The filter attenuation of the interfering signal is also unaffected by mixing. Assuming again that nonlinear effects are negligible, it is also unnecessary to include mixer effects in the RF/IF section model.

Typically, each RF/IF stage contains bandpass filtering to reduce or eliminate unwanted signals. A given bandpass filter is centered on a specific frequency. An interfering signal at a given frequency separation from this center frequency will generally experience some attenuation. The attenuation vs. frequency separation function is the *selectivity* of the filter. Although different filters in the RF/IF section have different center frequencies, the filter selectivities can be aligned and added (in dB) to form one composite function. Thus the RF/IF section model is simply a model of a single composite filter. The selectivity of that filter is known as the *receiver selectivity*.

The RF/IF filter produces two effects that significantly impact performance. The first effect is that interfering signals may be attenuated by the filter. The FDR is the total attenuation integrated across the interfering signal spectrum (Section 3.2). Viewed as a transfer function, the FDR relates the interference power at the RF/IF input to the interference power at the RF/IF output.

The second effect is that the shape of the interfering signal waveform may be changed by the RF/IF filter (Section 3.3). For example, the pulses in a pulsed radar signal may be smeared together so that the resulting signal is no longer pulsed. These waveform changes may result in corresponding changes in the receiver performance measure.

Here it is worthwhile to introduce a definition of “waveform.” In general usage, the term waveform refers to a known set of characteristics.

3.2 FDR

FDR is a measure of the rejection produced by the receiver selectivity curve on an unwanted transmitter emission spectra. The total filter loss is translated to the IF frequency. The FDR is the total filter loss experienced by an interfering signal in all the RF/IF stages in a receiver. The FDR is the ratio of the input interference power to the output (filtered) interference power (see illustration in Figure 3.2-1). Thus, FDR is a calculation of the amount of undesired transmitter

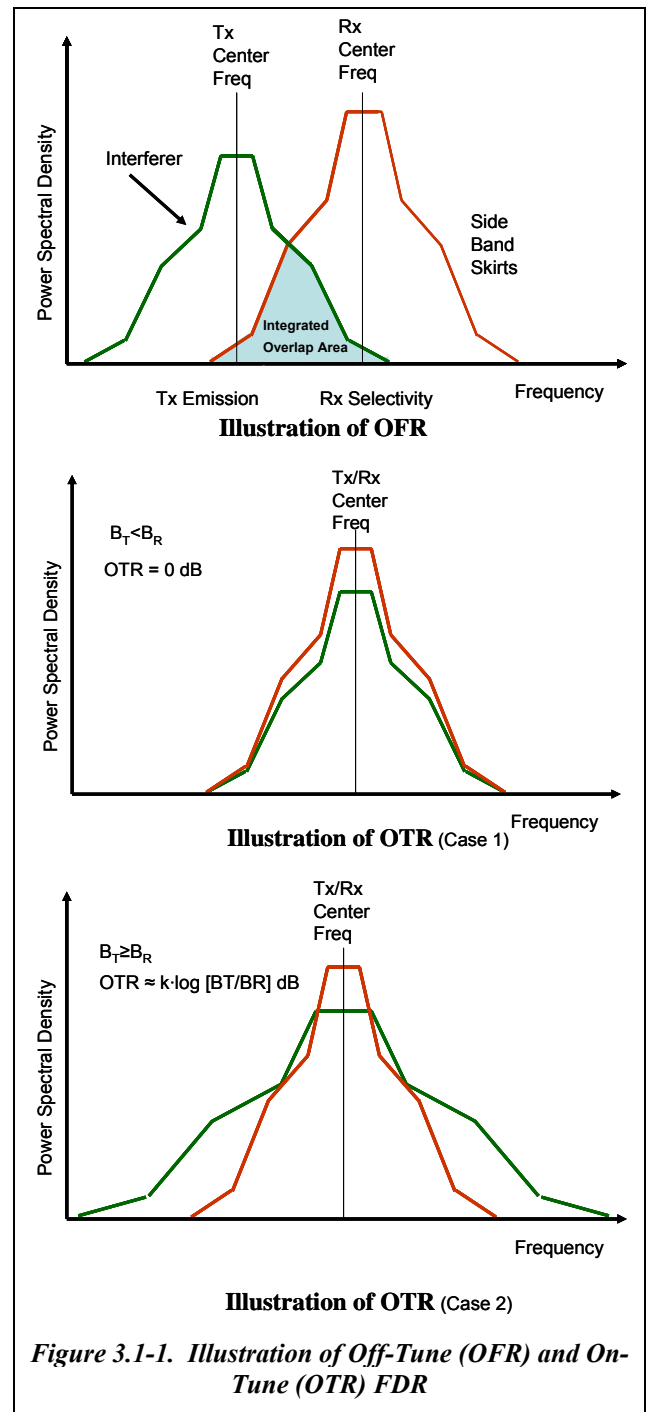

Figure 3.1-1. Illustration of Off-Tune (OFR) and On-Tune (OTR) FDR

energy that is rejected by a victim receiver. FDR details can be found in Recommendation ITU-R SM.337-6, and are summarized below.

$$FDR(\Delta f) = 10 \log_{\infty} \frac{\int_0^{\infty} P(f) df}{\int_0^{\infty} P(f) |H(f + \Delta f)|^2 df} \text{ dB} \quad (3-1)$$

where

$P(f)$ = power spectral density of the interfering signal

$H(f)$ = equivalent IF response of the receiver

and

$$\Delta f = f_i - f_r$$

where

f_i = interferer frequency

f_r = receiver tuned frequency.

The FDR can be divided into two terms:⁶ (i) the On-Tune Rejection (OTR) and (ii) the Off-Frequency Rejection (OFR) which is the additional rejection which results from off-tuning the interferer and receiver.

$$FDR(\Delta f) = OTR + OFR(\Delta f) \text{ dB} \quad (3-2)$$

where

$$OTR = 10 \log_{\infty} \frac{\int_0^{\infty} P(f) df}{\int_0^{\infty} P(f) |H(f)|^2 df} \text{ dB} \quad (3-3)$$

$$OFR(\Delta f) = 10 \log_{\infty} \frac{\int_0^{\infty} P(f) |H(f)|^2 df}{\int_0^{\infty} P(f) |H(f + \Delta f)|^2 df} \text{ dB} \quad (3-4)$$

Per the ITU⁶ the OTR, also called the correction factor, can often be approximated by:

⁶ ITU-R Recommendation SM.337-6.

$$OTR \approx \begin{cases} 0 & \text{if } B_T < B_R \\ K \log\left(\frac{B_T}{B_R}\right) & \text{if } B_R \leq B_T \end{cases} \text{ dB} \quad (3-5)$$

where

- B_R = receiver 3 dB bandwidth (Hz)
- B_T = interferer 3 dB bandwidth (Hz)
- K = 20 for non-coherent and for pulsed signals
- K = 10 for deterministic signals

FDR can be expressed as a transfer function. Thus, assuming negligible insertion loss introduced by the IF filter to the signal, the input S/I (i.e., at receiver/LNA input) and output S/I (i.e., after IF filter) can be related as follows:

$$\left(\frac{S}{I}\right)_{\text{out}} = \left(\frac{S}{I}\right)_{\text{in}} + FDR \text{ dB} \quad (3-6)$$

It is important to also note that the data detection filter (which is set based upon data rate) is always more narrow than the IF filtering, and that the data detection filter truly defines the signal and interference powers at the instant of data decision.

The integral in the numerator of Equation 3-1 is the power at the receiver input. The integral in the denominator of Equation 3-1 is the power at the output of the receiver RF/IF filters. These integrals can be evaluated numerically, but Equation 3-1 is often approximated by simpler equations, as discussed below.

The interfering signal is assumed to be on-tune with the receiver if:

$$|\Delta f| \leq \text{Max}\left(\frac{B_T}{2}, \frac{B_R}{2}\right) \quad (3-7)$$

where

- Δf = frequency separation between the interfering signal and the desired signal, in Hz
- $\text{Max}(a,b)$ = function that takes the maximum of a and b
- B_R = receiver 3 dB bandwidth, Hz
- B_T = interferer 3 dB bandwidth, Hz

For an on-tune signal, the FDR is obtained from Equation 3-5. For an off-tune signal, the FDR is approximately:

$$\begin{aligned}
 FDR &= 10 \log \left(\frac{B_T}{B_R s(f_R - f_T) + B_T r(f_T - f_R)} \right) \\
 &= 10 \log \left(\frac{1}{\left(\frac{B_R}{B_T} \right) s(f_R - f_T) + r(f_T - f_R)} \right)
 \end{aligned} \tag{3-8}$$

where

$$\begin{aligned}
 s(f-f_T) &= \text{transmitter spectrum at frequency } f \\
 r(f-f_R) &= \text{receiver response at frequency } f
 \end{aligned}$$

Equation 3-8 is obtained by expressing the integral in the denominator of Equation 3-1 as the sum of two integrals, one over the receiver region ($f \approx f_R$) and one over the transmitter region ($f \approx f_T$). It is then assumed that $s(f-f_T)$ is approximately constant in the receiver region and $r(f-f_R)$ is approximately constant in the transmitter region.

From Equation 3-5 with K set at 10, and Equation 3-8, the FDR in dB is given by

$$\begin{aligned}
 FDR &= 0 && \text{if on-tune and } B_T < B_R \\
 FDR &= -10 \log \left[\left(\frac{B_R}{B_T} \right) \right] && \text{if on-tune and } B_T \geq B_R \\
 FDR &= -10 \log \left[\left(\frac{B_R}{B_T} \right) s(f_R - f_T) + r(f_T - f_R) \right] && \text{if off-tune}
 \end{aligned} \tag{3-9}$$

As an example, suppose that an off-tune interfering signal has a 10-kHz bandwidth and that the receiver has a 4-kHz bandwidth. Also suppose that the transmitter spectrum is 20 dB down at the receiver frequency and the receiver selectivity is 30 dB down at the transmitter frequency. Then the FDR (in dB) is approximately:

$$\begin{aligned}
 FDR &= -10 \log \left[\left(\frac{B_R}{B_T} \right) s(f_R - f_T) + r(f_T - f_R) \right] \\
 &= -10 \log \left[\left(\frac{0.004}{0.010} \right) 10^{-20/10} + 10^{-30/10} \right] = 23 \text{ dB}
 \end{aligned} \tag{3-10}$$

3.3 BAND-LIMITING EFFECTS ON INTERFERING SIGNALS

The RF/IF composite filter may change the shape of the interfering signal waveform. A specification of the output waveform characteristics as a function of the input waveform characteristics is therefore an additional transfer function for the RF/IF section. There are three cases of interest: (1) when either the interfering transmitter or the receiver is a frequency hopper, (2) when the interfering signal is pulsed (either unmodulated or swept-frequency), and (3) when the interfering signal is digital.

3.3.1 Frequency Hoppers

Fixed-Frequency Receiver - Consider the case in which a frequency-hopping transmitter interferes with a fixed-frequency receiver. The interfering signal typically hops from one carrier frequency to another at some fixed hop rate (e.g., 100 hops/s). The *dwell time* is the duration of transmission at any particular frequency. For a small time interval when the transmitter is switching frequencies, the signal is turned off at the transmitter. This off-time is usually sufficiently small that the dwell time is approximately the reciprocal of the hop rate.

When the interfering signal frequency changes, the frequency separation between the interfering signal and the receiver changes. As a result, the FDR generally changes. Therefore, the interfering signal power at the RF/IF output may vary significantly from one hop to the next. In this case, an input signal that is essentially continuous (except for a small off-time) is converted into an intermittent signal that has large amplitude variations.

Frequency-Hopping Receiver - Consider the case in which a narrowband fixed-frequency transmitter interferes with a frequency-hopping receiver. When the desired signal frequency changes, the frequency separation between the interfering signal and the receiver changes, and the FDR changes. Therefore, the interfering signal power at the RF/IF output may vary significantly from one hop to the next. Just as in the previous case, the RF/IF section converts a continuous input signal into an intermittent signal.

If both the interfering transmitter and the receiver are frequency hoppers, essentially the same phenomenon occurs. The only difference is that the interfering signal power at the RF/IF output will change more frequently, because the FDR generally changes when either the interfering signal or the receiver changes frequencies.

Because the intermittent nature of the output interference is caused by fluctuating FDR values, there are cases involving frequency hoppers that don't result in intermittent output signals. In particular, a DS interfering signal (Section 4) may have a bandwidth that covers the entire range of frequencies in the receiver hopset. In that case, the FDR does not change when the receiver hops because every receiver frequency is on-tune with some portion of the interfering signal band. Therefore, the output signal is not intermittent.

3.3.2 Pulsed Interfering Signals

The RF/IF filters in a receiver may distort a pulsed interfering signal in such a way that the pulsewidth of the signal changes. The pulses may even be smeared together so that the resulting signal is no longer pulsed. In general, the type of distortion depends on whether the pulse is on-tune or off-tune. A pulse is on-tune if Equation 3-7 is satisfied. Although the spectrum of a pulsed signal consists of discrete lines, the signal bandwidth (which appears in Equation 3-7) is normally based on the envelope of the spectrum.

An important characteristic of the RF/IF composite filter is its *impulse response*, which is the reciprocal of the filter bandwidth ($1/B_R$). If B_R is in MHz, then $1/B_R$ is in μs . It characterizes the ability of the filter to resolve waveform events of short duration. For example, if $1/B_R$ is much less than the pulsewidth τ of a single on-tune input pulse, then the filter is able to produce an undistorted output pulse of the same duration τ . However, if $1/B_R$ is greater than τ , then the output pulsewidth is $1/B_R$ (because $1/B_R$ is the smallest resolvable pulsewidth). In this case, the energy of the input pulse is spread out to form a longer pulse of lower amplitude.

Table 3.3-1 specifies the signal waveform at the RF/IF output when the input interfering signal is pulsed. There are nine different cases shown. In all cases, the input signal is pulsed with a pulsewidth τ and a *PRI*, which is the time between the leading edges of two successive pulses. In some cases, the frequency of each pulse is linearly swept through a range of frequencies (Δf_c). The resulting signals are called *linear frequency modulated* or *chirp* signals. In Table 3.3-1, “NA” means that the item is not applicable. In Cases 2 through 8, the output waveform is a pulse train with the same *PRI* as the input waveform. In Case 9, the output waveform is a train of pulse pairs; the two pulses within a pair are separated by τ and successive pairs are separated by the same *PRI* as the input waveform.

Table 3.3-1. RF/IF Output Signals for Pulsed Interfering Input Signals

Case	Δf	Modulation	Bandwidth Condition	Resolution Condition	Output Waveform
1	On-tune or off-tune	Unmodulated or chirp	NA	$\frac{1}{B_R} \geq PRI > \tau$	Continuous CW-like signal
2	On-tune	Unmodulated	NA	$PRI > \frac{1}{B_R} > \tau$	One pulse per <i>PRI</i> with pulsewidth $1/B_R$
3	On-tune	Unmodulated	NA	$PRI > \tau \geq \frac{1}{B_R}$	One pulse per <i>PRI</i> with pulsewidth τ
4	On-tune	Chirp	$B_T > B_R$	$PRI > \frac{1}{B_R} > \frac{B_R}{B_T} \tau$	One pulse per <i>PRI</i> with pulsewidth $1/B_R$
5	On-tune	Chirp	$B_T > B_R$	$PRI > \frac{B_R}{B_T} \tau \geq \frac{1}{B_R}$	One pulse per <i>PRI</i> with pulsewidth $(B_R/B_T)\tau$
6	On-tune	Chirp	$B_R \geq B_T$	$PRI > \frac{1}{B_R} > \tau$	One pulse per <i>PRI</i> with pulsewidth $1/B_R$
7	On-tune	Chirp	$B_R \geq B_T$	$PRI > \tau \geq \frac{1}{B_R}$	One pulse per <i>PRI</i> with pulsewidth τ
8	Off-tune	Unmodulated or chirp	NA	$PRI > \frac{1}{B_R} > \tau$	One pulse per <i>PRI</i> with pulsewidth $1/B_R$
9	Off-tune	Unmodulated or chirp	NA	$PRI > \tau \geq \frac{1}{B_R}$	Two pulses per <i>PRI</i> , separated by τ , each with pulsewidth $1/B_R$

3.3.2.1 Unresolvable Pulses

In Case 1, the impulse response $1/B_R$ is greater than the time between pulses (*PRI*). This case includes on-tune or off-tune signals that may be chirp or unmodulated. A single pulse by itself would be stretched to the duration $1/B_R$. However, because this duration is greater than the time between pulses, the stretched pulses in a pulse train overlap and form a continuous waveform. The exact nature of this waveform depends on where the spectral lines lie relative to the receiver passband. In the worst case, there is one spectral line within the receiver passband. In this case, the output waveform is typically CW-like.

3.3.2.2 On-tune and Unmodulated Pulses

In Cases 2 and 3, the input interfering signal is an on-tune and unmodulated pulsed signal. In Case 2, the impulse response is less than the PRI but greater than the input pulsewidth. Each pulse is stretched to the duration $1/B_R$. Thus, the output waveform has one pulse of pulsewidth $1/B_R$ for each input pulse. In Case 3, the impulse response is less than the input pulsewidth, so the filter is able to produce an undistorted output pulse of the same duration. Thus, the output waveform has one pulse of pulsewidth τ for each input pulse.

3.3.2.3 On-tune Shortened Chirp Pulses

In Cases 4 and 5, the input interfering signal is an on-tune chirp signal. For this type of signal, there is one additional factor to consider. If the frequency of the pulse is swept through a range of frequencies Δf_c that exceeds the IF bandwidth, then the pulse will be attenuated at any frequencies outside the IF bandwidth. This shortens the pulsewidth by the factor $B_R/\Delta f_c$. Because the transmitter bandwidth B_T is nominally equal to Δf_c , the shortening factor is B_R/B_T . The bandwidth condition $B_T > B_R$ specifies that Δf_c does not exceed the IF bandwidth. Cases 4 and 5 are the same as Cases 2 and 3, except that the shortened pulsewidth $[(B_R/B_T)\tau]$ replaces the pulsewidth τ .

3.3.2.4 On-tune Unshortened Chirp Pulses

Cases 6 and 7 are the same as Cases 4 and 5, except that the bandwidth condition $B_R \geq B_T$ specifies that Δf_c does not exceed the IF bandwidth. Since the pulse does not sweep to frequencies outside the IF bandwidth, the pulse shortening effect does not occur. Therefore, Cases 6 and 7 are equivalent to Cases 2 and 3, respectively.

3.3.2.5 Off-tune Pulses

In Cases 8 and 9, the input interfering signal is an off-tune pulsed signal. For an off-tune pulse, whether it is an ordinary or a chirp pulse, the filter produces an impulse response at each edge of the pulse that experiences less attenuation (FDR) than the center of the pulse. If $1/B_R$ is less than τ (Case 9), then the resulting output waveform is a pair of pulses of width $1/B_R$, separated by the original pulsewidth. If $1/B_R$ is greater than τ (Case 8), then the two edge responses overlap to form one pulse of width $1/B_R$.

3.3.2.6 Analysis Considerations

The analysis results presented in the Handbook include pulsed interferer scenarios. The discussion below is provided in the event the Handbook performance degradation curves are insufficient to adequately evaluate a particular pulsed interference scenario.

Case 1 in Table 3.3-1 converts a pulsed signal into a signal that is not intermittent. Because the RF/IF output signal is not pulsed, the *average power* of the signal (averaged over a complete pulse repetition interval), rather than the *peak power* (power during the pulse), should be used in the analysis. These are related as follows:

$$P_{\text{avg}} = P_{\text{peak}} + 10 \log\left(\frac{\tau}{PRI}\right) \quad (3-11)$$

where

$$P_{\text{avg}} = \text{average power of the signal, dBm}$$

P_{peak}	=	peak power of the signal, dBm
τ	=	pulsewidth, μs
PRI	=	pulse repetition interval, μs

Section 3.4 gives a brief introduction to the types of analysis that may be appropriate when the pulsed interference scenario cannot be evaluated using the techniques and data presented in this Handbook. In such an analysis, it is necessary to include the fact that the peak power of the output pulse may differ from the peak power of the input pulse, not only because of FDR but also because the energy is spread across a different pulsewidth. These are related as follows:

$$P_{\text{out}} = P_{\text{in}} - FDR + 10 \log \left(\frac{\tau}{\tau_{\text{out}}} \right) - a \quad (3-12)$$

where

P_{out}	=	peak power of the output pulse, dBm
P_{in}	=	peak power of the input pulse, dBm
FDR	=	frequency dependent rejection, dB (Section 3.2)
τ	=	input pulsewidth, μs
τ_{out}	=	output pulsewidth, μs
a	=	$\begin{cases} 3 \text{ dB} & \text{for Case 9 (each output pulse has half the power)} \\ 0 \text{ dB} & \text{for Cases 2 through 8} \end{cases}$

3.3.3 Digital Interfering Signals

A digital interfering signal is similar in some ways to an unmodulated pulsed signal. Each bit (or chip for a spread spectrum transmitter) can be thought of as a pulse, but with no “dead time” between pulses. Many of the pulsed signal concepts from Section 3.3.2 are also applicable to digital signals, but most types of distortion have little effect on receiver performance. However, one type of distortion occurs that is significant: when the interfering signal bit duration is less than the impulse response ($1/B_R$) of the RF/IF composite filter, then the output interfering signal is a noise-like signal.

3.4 ANALYSIS WITH PULSED SIGNALS

When interfering signals are pulsed, the analysis method of this Handbook accommodates the scenario. However, there are limitations to the analysis technique described in this Handbook and the supporting data which the analysis technique relies upon. In the event the Handbook analysis approach or supporting data is insufficient for a particular pulsed interference scenario, a manual analysis approach is described below.

As an initial example, consider a digital receiver with no FEC and an interfering signal that has a power level I for 2% of the time and negligible power for the other 98%. It could be a pulsed radar signal for which the pulsewidth is 2% of the pulse repetition interval. Or it could be a narrowband fixed-frequency interfering signal that is in the same channel as one of the 50 hopset frequencies of a frequency-hopping receiver. If the receiver is affected by the interference only when it falls in the

same channel, then that co-channel event is like an interference pulse whose duration is 2% (1/50) of the total time spent hopping through the entire hopset. For either case, the BER is given by:

$$BER = 0.98 BER_N + 0.02 BER_{I+N} \quad (3-13)$$

where

BER = average BER

BER_N = BER in the presence of noise

BER_{I+N} = BER in the presence of both interference and noise

Alternatively, rather than calculate a BER, the pulse may be called an outage and the statistics of the outage (e.g., a 10 ms outage that occurs every 500 ms) may simply be reported.

Although this simple example can be analyzed with a simple manual technique, many cases are too complex to analyze manually. For example, there may be multiple radars with different pulsedwidths and power levels simultaneously interfering with the receiver. Or the narrowband fixed-frequency signal interfering with the frequency-hopping receiver could have many amplitude levels at the RF/IF output (rather than just two levels) because of changes in the FDR as the receiver hops. Equation 3-13 can be generalized as follows:

$$BER = \sum_j p_j BER_j \quad (3-14)$$

where

BER = average BER

p_j = probability that the j^{th} interference level occurs

BER_j = BER when the interference is at the j^{th} level

It may be difficult to determine the statistics (e.g., values of p_j) required to use Equation 3-13. In addition, if the receiver has FEC then Equation 3-14 may not be valid. In that case, the relative duration of an interference event and the FEC code word may be important. (A brief discussion of FEC with intermittent signals is given in Section 7.4.) The best approach for analyzing these complex cases is the simulation approach (Section 2.4.4).

Note that the desired signal may also be intermittent. For example, if a frequency-hopping receiver is subject to frequency-selective multipath fading, then the desired signal power will fluctuate (fade) as the receiver hops.

3.5 SUMMARY

There are two transfer functions associated with the RF/IF section of a receiver. The first is the FDR, which relates the S/I at the RF/IF input to the S/I at the RF/IF output according to Equation 3-6. The FDR is defined by Equation 3-1 and can be approximated in dB by Equation 3-8. The second is a non-mathematical transfer function that relates the interference waveform characteristics at the RF/IF input to the interference waveform characteristics at the RF/IF output. It is specified for frequency hopping, pulsed, and digital signals in Sections 3.3.1, 3.3.2, and 3.3.3, respectively.

SECTION 4 - DESPREADER

This section describes spread spectrum processing and characterizes the processing gain associated with the despreader in a spread spectrum system. Because spread spectrum is frequently associated with multiple access, some simple multiple-access equations are also presented.

4.1 DESCRIPTION

In a transmitter, *spreading* is the process of multiplying the narrowband information signal by a wideband code waveform to dramatically increase the bandwidth of the signal. In the receiver, *despreading* multiplies the wideband desired signal by the same code waveform to recover the original narrowband signal. A *spread spectrum* system is a system that employs spreading and despreading. An RF system may employ spread-spectrum technology for several reasons:

- To enable multiple-access communications with many users utilizing the same portion of the RF spectrum at the same time without unacceptable mutual interference
- To suppress narrowband interference
- To resist multipath fading

The operation of a spread-spectrum system is based on a PN spreading code set, which is known by both the transmitter and receiver. A PN code set is a collection of binary sequences (called keys, spreading codes, or simply codes) with the following properties:

- The autocorrelation of each code is very small.
- The cross-correlation of multiple distinct codes is very small.
- The RF waveform representing each code appears to be noise-like.

The desired signal is spread with a particular PN code waveform. When the despreader multiplies the desired signal by that same PN code waveform, it removes the code. As a result, the original narrowband desired signal is recovered. This despreading works because the receiver-generated PN code waveform is synchronized with the PN code waveform on the desired signal and is, therefore, perfectly correlated. After the despreader, the narrowband desired signal passes through a narrow bandpass filter.

If the receiver is part of a multiple-access system and the received signal includes an interfering signal from a different user in the system, then that signal is also multiplied by the receiver PN code waveform. However, the PN code on the interfering signal does not match the receiver PN code. Because the two codes are uncorrelated, the interfering signal is not despread. When the wideband interfering signal at the despreader output then passes through the narrow bandpass filter, much of it is attenuated. This attenuation is what allows a spread spectrum multiple-access receiver to distinguish and extract the desired signal from the composite signal that includes signals from multiple users.

The same mechanism in a spread spectrum receiver suppresses narrowband interference. When the despreader multiplies the narrowband interfering signal by the receiver-generated PN code waveform, the interfering signal is spread (becoming a wideband signal). When that wideband signal then passes through the narrow bandpass filter, much of it is attenuated.

In both of these cases, despreading (followed by narrowband filtering) can produce a dramatic improvement in the S/I. This improvement is called the processing gain. The types of spreading are DS, frequency hopping, and time hopping.

Spread-spectrum systems resist fading. In a frequency-selective multipath fading environment, typically only a small portion of the large spread-spectrum bandwidth experiences fading. The degradation normally caused by propagation delays is minimized by the despreader.

Distinction between synchronized and unsynchronized Code Division Multiple Access (CDMA) interferers:

A CDMA system will have a mix of synchronized users and unsynchronized users. Both user types will act as multiple access interference to the desired user. Receiver algorithms for interference cancellation schemes for both kinds of interference have been the subject of extensive research to develop optimum receiver architectures.

However, the effects of interference in a CDMA communications receiver caused by other CDMA users within a synchronized CDMA system differs from that caused by other spectrum users that are not synchronized with the desired signal. Example of synchronized (code noise) interference in cellular systems is multiple access interference due to other simultaneous users within a desired cell/sector (i.e., intracell intrasector interference). Whereas, unsynchronized interference is the interference due to other cell or sector base stations and users (intercell/intersector interference). Both types of interference effects should be taken into account in calculating the total effective $E/(N_o+I_o)$ when evaluating link performance.

4.2 DIRECT SEQUENCE

In a DS system, the code waveform is usually a long pseudorandom sequence of short-duration bits known as *chips*. The transmitter spreads a digital signal by multiplying the signal by the code waveform. The coded waveform is typically transmitted and received using a binary digital modulation scheme, such as phase-shift keying (PSK) or differential PSK (DPSK). The spreading can occur before, during, or after the modulation process.

As an example of one common implementation, consider a case with 100 chips per bit. The information bit sequence is combined with FEC bits to produce the coded bit waveform $b(t)$, which is a series of rectangular pulses. Each pulse has an amplitude ± 1 . The FEC-coded bit rate is R_b in bits/s. The spreading sequence is represented by the PN code waveform $c(t)$, which is also a series of rectangular pulses of amplitude ± 1 . The chip rate of the PN code is $R_c = 100 R_b$. In the transmitter, the spreader multiplies the two waveforms together to get the spread baseband waveform $b(t) c(t)$. That waveform then modulates a carrier to get a PSK signal. In the receiver, the received PSK signal is demodulated to recover the baseband waveform $b(t) c(t)$. The despreader then synchronizes its local PN code waveform $c(t)$ with the input signal and multiplies the two waveforms to get $[b(t) c(t)][c(t)] = b(t) c^2(t) = b(t)$. Thus, in the absence of interference and noise, the original FEC-coded bit waveform $b(t)$ is recovered. If interference and noise are not negligible, then the received bit sequence will contain bit errors and the FEC decoder will attempt to correct those errors.

4.2.1 Processing Gain

The RF bandwidth B_c associated with the desired signal waveform before despreading is much larger than the bandwidth B_b associated with the desired signal waveform after despreading. The bandpass filter following the despreader has a nominal bandwidth B_b .

When the spread-spectrum desired signal is accompanied by narrowband interference, the despreader expands the interfering signal bandwidth from B_I to approximately B_c . The bandpass filter then attenuates the interference by the factor B_c/B_b . This factor, expressed in dB, is the spread-spectrum processing gain:

$$G_{SS} = 10 \log\left(\frac{B_c}{B_b}\right) \approx 10 \log\left(\frac{R_c}{R_b}\right) = 10 \log(M) \quad (4-1)$$

where

G_{SS}	=	spread-spectrum processing gain, in dB
B_c	=	3-dB bandwidth of the desired signal before despreading, in MHz
B_b	=	3-dB bandwidth of the desired signal after despreading, in MHz
R_c	=	chip rate of despreader, in chips/s
R_b	=	bit rate at despreader output, in bits/s
M	=	number of chips per bit

If the interference is wideband with $B_I > B_c$, then the RF/IF section of the receiver (Section 3) reduces the interfering signal bandwidth from B_I to approximately B_c . That bandwidth reduction is accompanied by an attenuation, which is included in the FDR (Section 3.2). When the despreader multiplies the interfering signal by the PN code waveform, the interfering signal bandwidth remains approximately equal to B_c . The bandpass filter then attenuates the interference by the factor B_c/B_b . Therefore, Equation 4-1 also applies to the wideband interference case. Note that the FDR accounts for filter attenuation in the RF/IF section, whereas the processing gain accounts for filter attenuation in the bandpass filter that follows the despreader.

Multipath fading, which is a form of self-interference, can be modeled as narrowband interference to a DS system. Typically, a fade margin is planned for a communications link in which fading is anticipated. This fade margin can be reduced (by an amount less than or equal to the coding gain) when the system uses DS spread-spectrum communication.

4.2.2 Multiple-Access Interference

Since DS spread-spectrum systems are typically designed to support multiple-access communications within a single frequency band, it is frequently necessary to consider the effects of the multiple-access interference as well as noise. If it is assumed that there are K simultaneous users, then there will be one desired signal and $K-1$ undesired signals. If it is further assumed that the K signals are of equal power at the PSK receiver input, then the BER can be approximated as:⁷

⁷ Theodore S. Rappaport. *Wireless Communications Principles and Practice*. 2nd Ed., Prentice Hall. 2002.

$$BER = Q \left(\frac{1}{\sqrt{\frac{K-1}{3M} + \frac{N_o}{2E_b}}} \right) \quad (4-2)$$

where

- K = total number of simultaneous users
- M = number of chips per bit
- N_o = noise power density, in W/Hz
- E_b = energy per bit, in J (or W/Hz)

The variables E_b and N_o are discussed in Section 6. The function $Q(X)$ is defined as follows:⁸

$$Q(X) = \frac{1}{\sqrt{2\pi}} \int_X^{\infty} e^{-y^2/2} dy \quad (4-3)$$

For a single user the system is limited by noise:

$$BER = Q \left(\sqrt{\frac{2E_b}{N_o}} \right)$$

For a large number of users, the system is limited by the multiple-access interference:

$$BER = Q \left(\sqrt{\frac{3M}{K-1}} \right)$$

These equations assume that signals are received from all users with equal power. If this assumption is not valid, then other more complex equations may be used. To use these complex equations, the analyst must specify statistics describing the distribution of received signal power from all of the users. The only way to obtain such statistics is by field measurements. If such measurements are made, and it is determined that the variation of signal power is limiting the system capacity, the typical response is to reduce the variation. This can be done, for example, by reducing the coverage area or by inserting repeaters into the coverage area.

4.3 FREQUENCY HOPPING

In a *frequency-hopping* system, the desired signal is typically a digital signal that hops from one carrier frequency to another at some fixed hop rate. A *slow hopper* is one that transmits several bits during each hop. A *fast hopper* is one that hops several times during each bit. The system *hopset* is the set of possible frequencies. The transmitter uses a PN code to determine the sequence of frequencies from the hopset that will be used in a transmission. Typically, the PN code waveform is a long pseudorandom sequence of discrete voltages that control the output frequency of an oscillator.

⁸ John G. Proakis. *Digital Communications. 3rd Ed., McGraw-Hill Series in Electrical Engineering. 1995.*

The receiver uses the same PN code to convert the hopping desired signal to a fixed-frequency signal.

4.3.1 Processing Gain

Each of the frequencies in a hopset is the center frequency of what is called an instantaneous channel. Each instantaneous channel has an instantaneous bandwidth B_b . Typically, binary frequency-shift keying (FSK) modulation is used, so there are two signaling frequencies within each channel. Assuming there are M contiguous carrier frequencies and channels, the system bandwidth is $B_S = MB_b$. (A given channel is sometimes removed from a hopset to avoid interference in the environment.)

In a frequency-hopping receiver, a hopping local oscillator signal mixes with the desired signal. This process eliminates the desired signal hopping and converts a non-hopping interfering signal into a hopping signal. As in the case of a DS receiver, this shrinks the desired signal bandwidth and spreads the interfering signal spectrum. A non-hopping narrowband filter then filters out most of the interfering signal. This mixing and narrowband filtering normally occurs in the RF/IF section, so the resulting attenuation is already included in the FDR (Section 3.2). Therefore, although the concept of “processing gain” can be applied to a frequency-hopping receiver, Equation 4-1 is not used.

As discussed in Section 3.3.1, the interfering signal at the RF/IF output in a frequency-hopping receiver is usually intermittent, whether the hopper is slow or fast. Thus, the straightforward analysis method of this Handbook cannot be used. Section 3.4 discusses analysis options for such cases.

4.3.2 Multiple-Access Interference

In a frequency-hopping multiple-access system, mutual interference is minimized by designing the hopping sequences so that the probability of two users hopping to the same channel at the same time is small. If two users hop to the same channel at the same time, the event is called a *hit*. For a slow hopper, it may be assumed that during a hit the probability of bit error is 0.5. Adapting Equation 3-14 to this case, the BER is given by:

$$\begin{aligned}
 BER &= \sum_j p_j BER_j \\
 &= p_{\text{hit}} BER_{\text{hit}} + p_{\text{miss}} BER_{\text{miss}} \\
 &= (1 - p_{\text{miss}})(1/2) + p_{\text{miss}} BER_{\text{miss}}
 \end{aligned} \tag{4-4}$$

where

- p_{hit} = probability that a bit is a hit
- p_{miss} = probability that a bit is a miss (not a hit)
- BER_{hit} = BER during a hit
- BER_{miss} = BER during a miss

The probability of a hit is related to the number of simultaneous users, and the number of instantaneous carrier frequencies in the hopset. From the point of view of a single receiver, it cannot be assumed that all the signals hop synchronously. Even if there were a master system clock,

variations in propagation delay would result in varying degrees of offset. In this case, the probability that a bit is not in a hit can be obtained from

$$p_{\text{miss}} = \left[1 - \frac{1}{M} \left(1 + \frac{1}{L} \right) \right]^{K-1} \quad (4-5)$$

where

- M = number of frequencies in the hopset
- L = number of bits per hop, and K is number of simultaneous users

4.4 TIME HOPPING

In a conventional digital system, the bit duration is the reciprocal of the bit rate. For example, if the bit rate is 1000 bps then the bit duration is 1 ms. In a *time-hopping* system, the conventional bit interval (reciprocal of the bit rate) is conceptually subdivided into small subintervals. The bit is transmitted in one of these subintervals. To point out the similarity to a DS system, the small bit can be referred to as a *chip*. The position of the chip within the conventional bit interval is dictated by the PN code waveform. The frequency does not hop. Spreading occurs because the chip duration is much less than the conventional bit duration.

In a time-hopping receiver, the PN code waveform dictates where in the hopping interval the pulse is located. No energy is collected outside of that pulse window, so most of the interfering signal power is not collected. Equation 4-1 can be used to calculate the processing gain.

For example, consider a system with no FEC for which the conventional bit duration is 100 times the chip duration. If the bit rate is 1000 bps, then the conventional bit duration is 1 ms and the chip duration is 0.01 ms. In the transmitter, the information chip is placed in the n^{th} chip location, where n is a pseudorandom integer between 1 and 100 specified by the PN code. In the receiver, the despreader uses the same PN code to determine the value of n . It then converts the chip waveform back into the conventional bit waveform. The number of chips per bit (ratio of conventional bit duration to chip duration) is 100, so the processing gain is $10 \log(100) = 20$ dB.

4.5 SUMMARY

The transfer function associated with the despreader is the spread-spectrum processing gain, which relates the S/I at the despreader input to the S/I at the despreader output. The spread-spectrum processing gain is given by Equation 4-1. The S/I is increased by that gain in a DS or time hopping receiver.

SECTION 5 - ANALOG DEMODULATOR

This section describes the demodulator model for amplitude modulation (AM) voice, FM voice, and broadcast television receivers. Subjective performance measures of intelligibility for voice systems are discussed. Transfer functions that relate output S/N to input S/N are presented. Curves that specify intelligibility measures as a function of S/N and S/I are also displayed.

5.1 INTRODUCTION

The purpose of the analog demodulator is to remove the RF carrier and restore the baseband signal that was used to modulate the carrier. There are two common types of analog modulation – AM and FM – each with advantages and disadvantages pertinent to RF communications.

There are several properties of analog RF systems that affect the system performance:

Bandwidth. AM systems require less bandwidth than FM systems. A typical AM system requires an RF channel that is approximately twice the width of the baseband signal spectrum. Since an analog speech signal has a baseband width of less than 4 kHz, an AM system can accommodate many channels. Single-sideband AM systems require even less bandwidth – approximately the width of the baseband spectrum. FM systems require several times the bandwidth of the baseband spectrum.

Susceptibility to Noise and Interference. FM systems are generally less susceptible to noise, and are particularly less susceptible to intermittent interference and fading than AM systems. FM systems have a property that allows this immunity to be increased by increasing the RF bandwidth. AM systems do not have this property, leaving an increase in transmitter power as the principle means for overcoming noise and interference.

Threshold. Analog systems have a certain threshold, which is a received-signal power below which no usable output is obtained. AM systems can often operate at lower sensitivities than FM systems. FM systems, on the other hand, exhibit the so-called capture effect, which controls the way in which the output performance relates to increasing received-signal power. The capture effect allows the performance of the system, once the sensitivity threshold has been reached, to increase.

5.2 VOICE PERFORMANCE MEASURES

The performance of RF communications receivers is typically quantified in terms of S/N, or some similar ratio of desired-signal power to undesired-signal power. This is an objective measure of performance, in the sense that it can be measured with RF test equipment.

Objective measures of performance do not directly address properties such as fidelity or intelligibility, since these properties depend on human perception. Nevertheless, it is these properties that are ultimately of interest to users of RF communications systems. Consequently, there have been attempts to develop measures of performance that are more closely aligned with human perception.

5.2.1 Speech Intelligibility and Articulation Index

Speech Intelligibility - One of the most important applications of RF communications technology is the transmission of speech. The most basic and fundamental property that can be applied to a speech signal is intelligibility – that is, the ability of the listener to understand the speaker. Speech intelligibility is a measure of how well speech can be understood by a listener. The frequency range

of human speech is 50 Hz to about 10 kHz. However, the frequencies from 200 Hz to 6 kHz are generally considered to be the most significant to speech intelligibility.

Certain parts of the speech spectrum are more sensitive to noise and interference than others. For this reason, a measure of performance was developed that assigns varying weights to undesired signal power, based on the part of the speech spectrum that the signal occupies. This measure of performance, called the AI, is based on empirical data that shows the correlation between the undesired signal spectrum and the intelligibility of the speech. Although the basis of the AI is empirical, the definition of AI is not. It is effectively a frequency-weighted average because the sub-bands are of unequal width. Because the AI model is based on the long-term average speech and interfering signal spectrum, it cannot be used when either signal is intermittent.

Articulation Index - Because the relative sensitivity of human hearing states that human hearing is not equally sensitive at various octave bands, a weighting factor must be applied to each band. This is because, Frequency-Weighted S/N recognizes that noise in certain frequency bands is less harmful than that in other bands of an input signal, and that the speech in certain frequency bands contributes more to intelligibility/recognition rate than in other bands. AI has been shown to be a valid predictor of speech intelligibility under a wide variety of conditions involving noise masking and speech waveform distortion. AI is basically a speech intelligibility measure that ranges from 0.0 to 1.0.

The AI can also be computed using the following methods:

- ANSI S3.5-1969 (R 1986) Methods for Calculating AI.⁹
- Pavlovic's Articulation Index Method.¹⁰
- Kryter (1962).¹¹

The ANSI (1986) method requires thresholds for 250, 500, 1000, 2000, and 4000 Hz and the Pavlovic (1991) method requires those frequencies plus 1500, 3000, and 6000 Hz. The Kryter (1962) method uses the same speech band range of 200 up to 6000 Hz as the ANSI method; however, it divides the bands into one third octave based on 20 non-uniform, experimentally derived, sub-bands of increasing bandwidth. The AI calculation procedure has also been standardized in ANSI Standard S3.5-1969. In our analysis and calculation of the AI, we will follow the ANSI approach since it has also been adopted by DoD.

We will consider speech levels within five octave bands centered at 250 Hz to 4 kHz as shown in Table 5.2-1. Since the speech level usually refers to the long term value for normal speakers, octave spectra is considered to be sufficient for simple calculations. Thus, the “five sub-bands octave” approach is not expected to significantly impact the accuracy of AI calculations compared to using higher resolution (15 sub-bands or above) approaches. Thus the AI can be calculated from:¹²

⁹ American National Standards Institute. *Methods for Calculating AI, Octave Band Values, and Preferred Frequencies. ANSI S3.5-1969 R. 1986.*

¹⁰ *Journal of the Acoustical Society of America. Derivation of Primary Parameters and Procedures for Use in Speech Intelligibility Predictions. Vol. 82:413-422. 1987.*

¹¹ *Journal of the Acoustical Society of America. Methods for the Calculation and Use of Articulation Index. Vol. 34, 1698-1702. 1962.*

¹² *Sentagi S. Utami. An Acoustical Analysis of Domes. Brigham Young University. August 2005.*

$$AI = \frac{1}{30} \sum_{i=1}^5 w_i (S/N)_i \tag{5-1}$$

where w_i represents the weighting factor for each octave band (see Table 5.2-1 below), and $(S/N)_i$ represents the S/N (in dB) in each octave band. In the AI calculation by Equation 5-1, it is important to note that the S/N range is restricted to 0-30 dB.

Typical simulation results for FM voice interference are shown in Section 5.5.6.

Table 5.2-1. Weighting Factors for AI Calculations

Sub-Band Center Frequency (Hz) f_c	Lower Freq for the sub-band $f_c / \sqrt{2}$	Upper Freq for the sub-band $f_c \cdot \sqrt{2}$	Weighing Factor w_i
250	176.78	353.55	0.072
500	353.55	707.11	0.144
1,000	707.11	1414.21	0.222
2,000	1414.21	2828.43	0.327
4,000	2828.43	5656.85	0.234

In practice, AI is used to characterize the effect of undesired signals on transmitted speech by assigning a qualitative descriptor to a range of AI values. Typical assignment based on published data might be:

- AI > 0.9 Good
- 0.9 ≥ AI > 0.7 Adequate intelligibility
- 0.7 ≥ AI > 0.44 Marginal intelligibility
- AI ≤ 0.44 Unacceptably poor intelligibility

5.2.2 Articulation Score

The ultimate test of system performance is to actually measure the intelligibility of transmitted speech by empirical methods. The experiments are designed to facilitate the comparison of a spoken message with the same message after it has been transmitted and received. The results are quantified by counting the number of correct vs. incorrect words in the received message as reported by test listeners. The percentage of correct words is called the AS. The AS is thus the most direct measure of system intelligibility. When designing AS experiments, it is important – but extremely difficult – to minimize the contribution of other variables that affect intelligibility. These variables include:

Age, education, and regional accent of speakers and listeners. AS experiments have been performed primarily on college campuses, using college students as listeners. This introduces the possibility that the uniform level of education (typically first or second year undergraduate) will bias the results. Furthermore, unless a number of colleges in different locations are involved (historically this is not the case), the local accents and speech patterns will bias the results.

Type of message content. The message may be designed to communicate information in small, discrete, uncorrelated units (for example numbers or lists of words). The units may be larger, yet remain discrete and more or less uncorrelated, such as a news broadcast. The message may be highly correlated, where there is one central idea, and individual words are not identically important.

The AS experiments favor the small, uncorrelated message units, but many real-world communications are very different.

Style of delivery. The message may be spoken in casual, conversational tones, or it may be delivered with urgency. The focus, concentration, and ultimately the AS of listeners can be affected by whether the message is delivered with a declarative or imperative style.

Vocabulary. If speakers employ a limited vocabulary which is known to and anticipated by the listeners, the AS will be much higher than otherwise. Limited vocabularies and very disciplined delivery styles are used for military, emergency response, scientific, and other types of technical communications. These systems can often be operated in very noisy RF environments.

The impact of these variables is such that AS results have very narrow applicability. The degree to which a particular system resembles a test system with respect to these variables is the degree to which the AS tests will prove useful. There have been attempts to relate AS to AI, since AI is supposed to factor in frequency-dependent intelligibility. Even so, the relationship between AS and AI varies widely, exhibiting strong dependence on the aforementioned variables.

5.3 AM VOICE

5.3.1 Description

The waveform of an AM signal is given by:

$$v(t) = A_c [1 + m(t)] \cos(2\pi f_c t) \quad (5-2)$$

where

$v(t)$	=	waveform magnitude at time t , in V
t	=	time, in s
A_c	=	constant signal amplitude, in V
$m(t)$	=	baseband (modulating) signal, unitless
f_c	=	carrier frequency, in Hz

For AM voice, the modulating signal $m(t)$ is the voice signal to be transmitted. The original voice signal is peak-limited and scaled so that the peak amplitude of $|m(t)|$ is not greater than 1. That peak amplitude is called the *modulation index* μ of the AM signal.

AM results in frequency translation of the baseband spectrum. The translated baseband spectrum is referred to as a *sideband*. Equation 5-2 results in a pair of sidebands – each a replica of the baseband spectrum – centered about the carrier frequency f_c . There are several variations of amplitude modulated systems in which parts of the signal are suppressed. This section considers the full AM signal with carrier and two sidebands. The variations are specified in Section 5.4.

5.3.2 Performance

Important considerations are the demodulator threshold, sensitivity, and the output S/N. These are functions of the input S/N. It should be noted that the AM demodulator can never improve upon the input S/N. Ideal AM demodulation would result in an output S/N equal to the input S/N.

The demodulator needs a certain minimum input S/N to function properly. The *AM threshold* is a point on the curve of output S/N vs. input S/N at which the curve changes dramatically. Above threshold, the input vs. output S/N relationship is linear. Below threshold, the output S/N falls off faster than the input S/N. The threshold varies somewhat, depending on the type of demodulator circuit, but a reasonable approximation is an input S/N of approximately 5 dB. This is so low that, even if the demodulator were operating in the linear range, the output would not be usable. Sensitivity is the minimum received-signal power required for proper receiver operation in an interference-free environment. For analog receivers, “proper operation” is usually specified in terms of the output S/N. Therefore, a design goal for the RF engineer is to ensure that the required received-signal power is available. Sensitivity is usually determined experimentally.

In some analyses not involving interference, it may be sufficient to simply compare the received-signal power with the sensitivity. In other cases, it may be necessary to estimate the actual output S/N. For example, there may be a range of 10 to 15 dB in input S/N between the demodulator threshold and the sensitivity. If the system is operating in this range, the output will be noticeably degraded, but possibly still useful. At the other extreme, for critical messages it may be necessary to operate with a higher output S/N than that specified in connection with sensitivity.

5.3.3 Transfer Function

For an AM demodulator operating above threshold with noise (or noise-like interference), the output S/N is related to the input S/N as follows:

$$\left(\frac{S}{N}\right)_{\text{out}} = \left(\frac{S}{N}\right)_{\text{in}} + 10 \log\left(\frac{\langle m^2(t) \rangle}{1 + \langle m^2(t) \rangle}\right) \quad (5-3)$$

where

$(S/N)_{\text{out}}$ = output signal-to-noise power ratio, in dB

$(S/N)_{\text{in}}$ = input signal-to-noise power ratio, in dB

$\langle m^2(t) \rangle$ = time average of the square of $m(t)$, unitless

The numerator in the rightmost term of Equation 5-3 is the power of the modulating signal (in 1 ohm) relative to the carrier power. In a typical application, the root-mean-square (RMS) voltage of the voice signal $m(t)$ is 0.3 (relative to the carrier amplitude). Therefore, $\langle m^2(t) \rangle = 0.09$ and the rightmost term has the value -11 dB. The output S/N is 11 dB lower than the input S/N because the demodulator eliminates the carrier, which contains most of the power of the input signal.

If the modulating signal is a sinusoidal tone with modulation index μ (rather than a voice signal), then the transfer function is:

$$\left(\frac{S}{N}\right)_{\text{out}} = \left(\frac{S}{N}\right)_{\text{in}} + 10 \log\left(\frac{\mu^2 / 2}{1 + \mu^2 / 2}\right) \quad (5-4)$$

For an AM demodulator operating above threshold with AM voice interference, simulations show the transfer function to be:

$$\left(\frac{S}{I}\right)_{\text{out}} = \left(\frac{S}{I}\right)_{\text{in}} - 8 \quad (5-5)$$

In these simulations, the RMS voltage of each voice signal was set to 0.3 (relative to the carrier amplitude).

5.3.4 AI Curves

Figures 5.3-1 and 5.3-2 show AI curves for an AM voice receiver. In these graphs, the term “interference” and the variable I refer to non-noise-like interference. Any noise-like interference power is simply assumed to be added (in mW) to the noise power. For example, suppose there are two interfering signals: an amplitude-shift keying (ASK) signal and a noise-like signal. The S/I parameter is the ratio of the desired signal power to the ASK interfering signal power, and the x-axis variable S/N is the ratio of the desired signal power to the total noise-like power (including the receiver noise and the noise-like interfering signal) at the input of the receiver.

The curves were generated by time-domain simulation. The IF bandwidth was 8 kHz. The audio (baseband) bandwidth was from 300 Hz to 3.5 kHz. The modulation index of the desired signal was 0.3. In the last part of the simulation, the signals were transformed to the frequency domain for calculating the AI, as described in Section 5.2.1.

Figure 5.3-1 shows AI curves for an AM voice receiver with ASK (on-off keying) interference. There are six curves displayed. Each curve is a plot of AI vs. S/N. The top curve (labeled “No interference”) applies to the case in which there is no ASK interference. The other five curves are for cases with ASK interference. Each of those five curves is labeled with the S/I for that curve. As expected, each curve shows that the intelligibility (as indicated by the AI) improves as the S/N increases. As also expected, for a given S/N the intelligibility improves as the S/I increases.

In the simulation, the ASK interfering signal had a bit rate of 800 bps, but other simulations showed the results to be insensitive to the bit rate. (However, at very high bit rates the interfering signal is noise-like, as specified in Section 3.3.3.) The ASK signal was tuned 500 Hz away from the receiver, but other simulations showed the results to be insensitive to variations of off-tuning within the same frequency channel.

Figure 5.3-2 shows AI curves for an AM voice receiver with FSK interference. In the simulation, the FSK interfering signal had a bit rate of 50 bps and an off-tuning of 500 Hz, but other simulations showed the results to be insensitive to the bit rate and to variations of off-tuning within the same frequency channel. The frequency deviation of the FSK signal was ± 200 Hz.

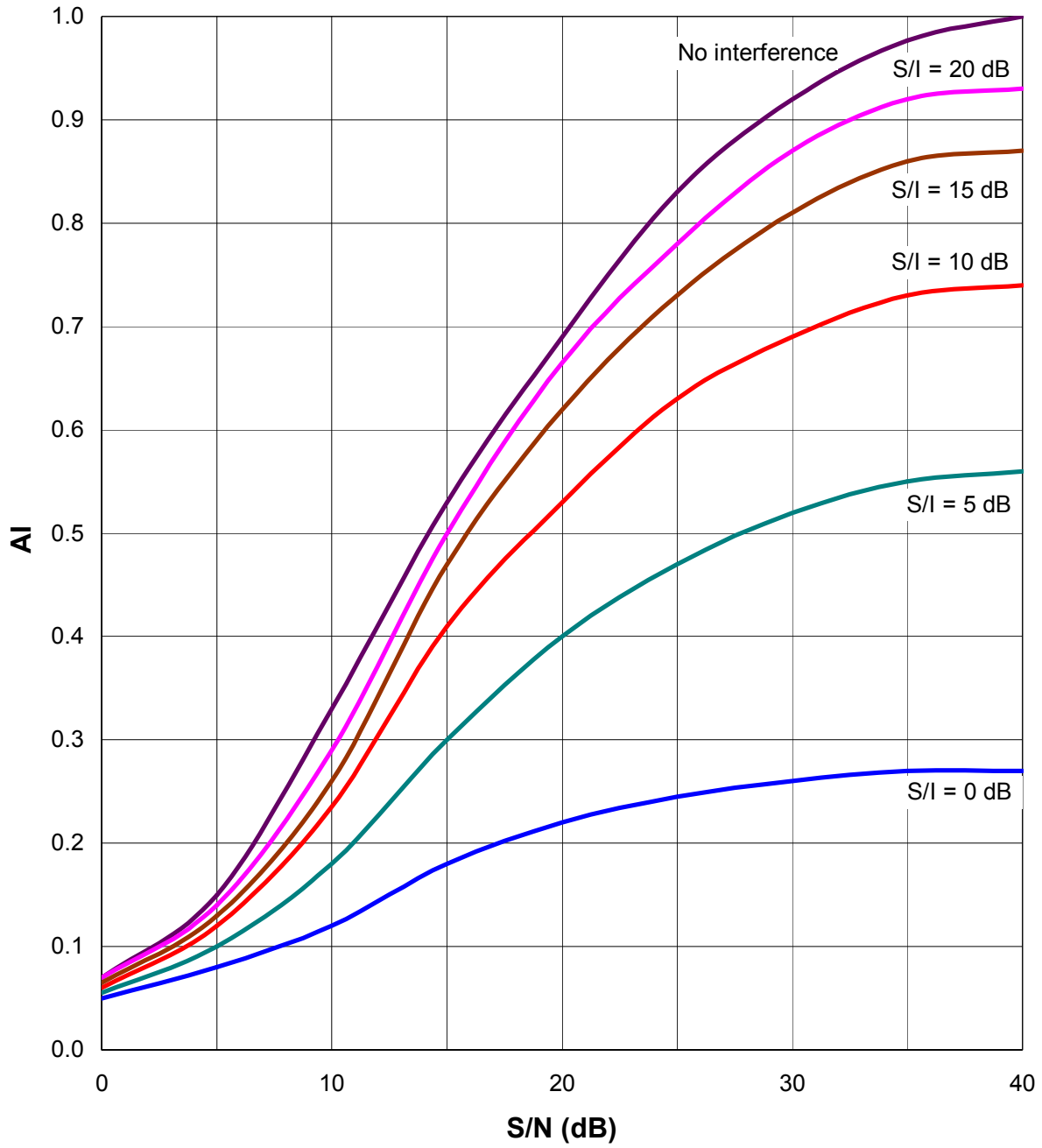

Figure 5.3-1. AI vs. $(S/N)_{in}$ Curves for AM Voice Receiver with ASK Interference

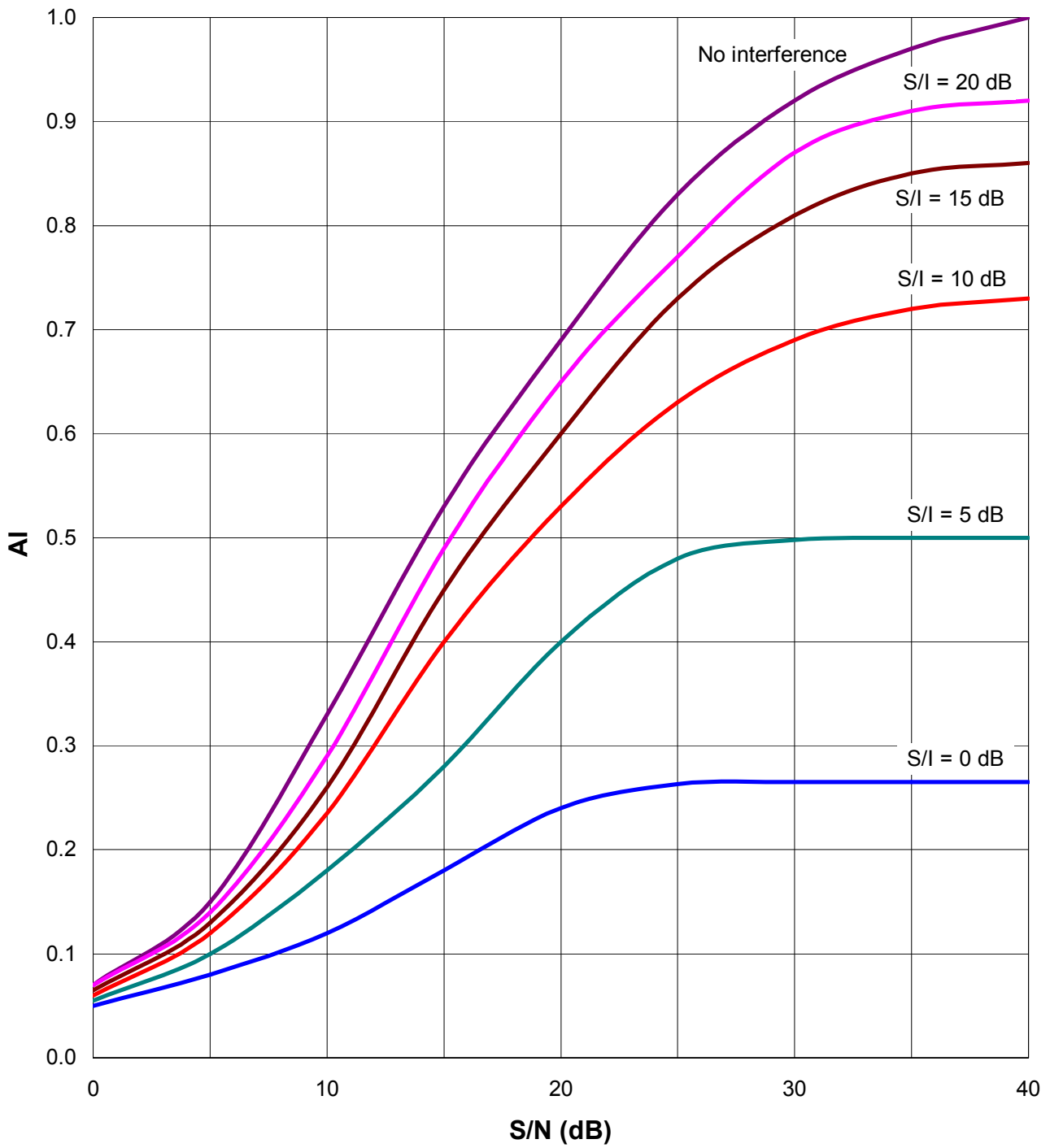

Figure 5.3-2. AI vs. $(S/N)_{in}$ Curves for AM Voice Receiver with FSK Interference

5.4 SINGLE SIDEBAND VOICE

5.4.1 Description

As described in Section 5.3, AM results in a pair of sidebands, each a replica of the baseband spectrum centered about the carrier frequency. There are several variations of AM systems:

- *Double sideband (DSB)*. This refers to the entire AM signal – the carrier and both sidebands. It is addressed in Section 5.3.
- *DSB with suppressed carrier*. The two sidebands are transmitted, but not the carrier.
- *Single sideband (SSB)*. Normally this means that only one of the sidebands is transmitted without the carrier.
- *SSB with pilot tone*. A single sideband is transmitted along with a pilot tone. The pilot tone is transmitted to aid in the demodulation process. This technique is especially useful in mobile systems, since it makes it possible to eliminate the effects of doppler shifts. The pilot tone may be the actual carrier frequency, but it does not have to be.
- *Vestigial sideband*. The carrier, one complete sideband, and a small portion of the other sideband are transmitted. This technique is used by analog broadcast television. It is addressed in Section 5.6.

5.4.2 Transfer Function

For systems that do not transmit the RF carrier, the output S/N is the same as the input S/N, assuming the system is operating above threshold:

$$\left(\frac{S}{N}\right)_{\text{out}} = \left(\frac{S}{N}\right)_{\text{in}} \quad (5-6)$$

Equation 5-6 applies to SSB receivers and to DSB receivers with suppressed carrier. For SSB systems with a pilot tone, the pilot tone may be assumed to be small enough that Equation 5-6 applies.

5.4.3 AI Curves

Figures 5.4-1 and 5.4-2 show AI curves for a SSB voice receiver. In these graphs, the term “interference” and the variable I refer to non-noise-like interference. Any noise-like interference power is simply assumed to be added (in mW) to the noise power. For example, suppose there are two interfering signals: an ASK signal and a noise-like signal. The S/I parameter is the ratio of the desired signal power to the ASK interfering signal power, and the x-axis variable S/N is the ratio of the desired signal power to the total noise-like power (including the receiver noise and the noise-like interfering signal).

The curves were generated by time-domain simulation. The IF bandwidth was 2.7 kHz. The audio (baseband) bandwidth was from 300 Hz to 3 kHz. The carrier and lower sideband were suppressed. The center frequency of the IF filter was assumed to be 1650 Hz above the suppressed carrier frequency. In the last part of the simulation, the signals were transformed to the frequency domain for calculating the AI, as described in Section 5.2.1.

Figure 5.4-1 shows AI curves for a SSB voice receiver with ASK interference. There are six curves displayed. Each curve is a plot of AI vs. S/N. The top curve (labeled “No interference”) applies to the case in which there is no ASK interference. The other five curves are for cases with ASK interference. Each of those five curves is labeled with the S/I for that curve. As expected, each curve shows that the intelligibility (as indicated by the AI) generally improves as the S/N increases. As also expected, for a given S/N the intelligibility generally improves as the S/I increases.

In the simulation, the ASK interfering signal had a bit rate of 800 bps, but other simulations showed the results to be insensitive to the bit rate. (However, at very high bit rates the interfering signal is noise-like, as specified in Section 3.3.3.) The ASK signal was tuned 500 Hz away from the suppressed carrier, but other simulations showed the results to be insensitive to variations of off-tuning within the same frequency channel.

Figure 5.4-2 shows AI curves for a SSB voice receiver with FSK interference. In the simulation, the FSK interfering signal had a bit rate of 50 bps and an off-tuning of 500 Hz, but other simulations showed the results to be insensitive to the bit rate and to variations of off-tuning within the same frequency channel. The frequency deviation of the FSK signal was ± 200 Hz.

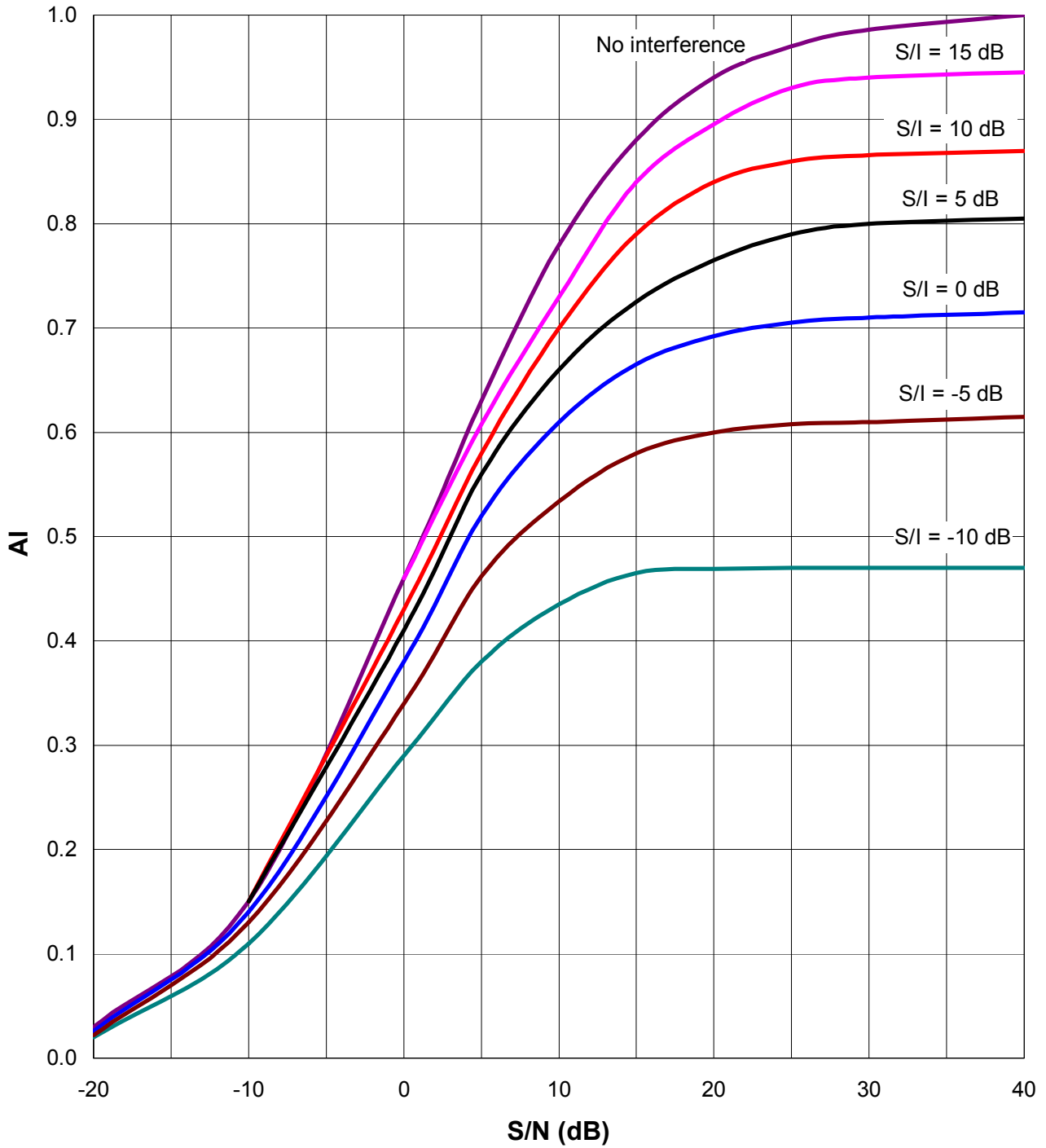

Figure 5.4-1. AI vs. $(S/N)_{in}$ Curves for SSB Voice Receiver with ASK Interference

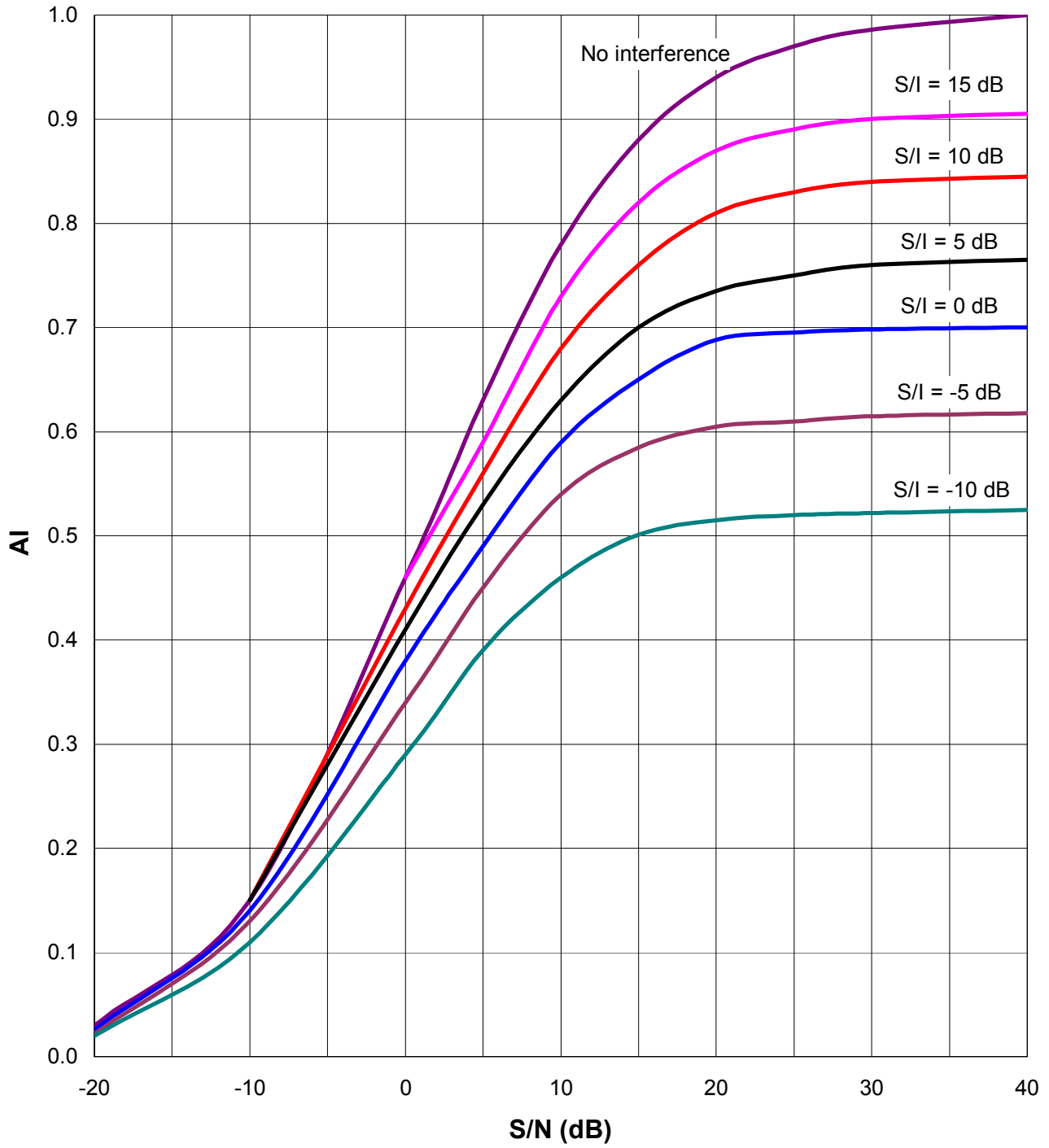

Figure 5.4-2. AI vs. $(S/N)_{in}$ Curves for SSB Voice Receiver with FSK Interference

5.5 FM VOICE

5.5.1 Description

An FM signal has an RF carrier whose instantaneous frequency depends on the amplitude of the modulating waveform. More precisely, the deviation of the RF carrier frequency from its unmodulated state f_c is made to be proportional to the amplitude of the modulating waveform $m(t)$. For FM voice, $m(t)$ is the voice waveform. However, properties of FM are more easily understood if the modulation is assumed to be sinusoidal. When the modulating waveform is a sinusoidal tone with frequency f_m , the FM signal may be written:

$$v(t) = A \cos[2\pi f_c t + \beta \sin(2\pi f_m t)] \quad (5-7)$$

where

$v(t)$	=	waveform magnitude at time t , in V
t	=	time, in s
A	=	constant signal amplitude, in V
f_c	=	carrier frequency, in Hz
β	=	modulation index (a unitless constant)
f_m	=	frequency of modulation tone, in Hz

The instantaneous frequency is the time derivative of the argument of the cosine function:

$$2\pi f = 2\pi f_c + \beta 2\pi f_m \cos(2\pi f_m t) \quad (5-8)$$

where

f	=	instantaneous frequency, in Hz
-----	---	--------------------------------

The maximum frequency deviation, which occurs when the modulating signal amplitude is at its maximum, is given by:

$$\Delta f = (f - f_c)_{\max} = \beta f_m \quad (5-9)$$

where

Δf	=	maximum (peak) frequency deviation, in Hz
------------	---	---

The bandwidth of an FM signal depends on the modulation index β and is found to be:

$$B = 2(\beta + 1)f_m = 2(\Delta f + f_m) \quad (5-10)$$

If $\beta \gg 1$, then $B \approx 2\Delta f$

The factor 2 in the equation is to account for both the upper and lower sidebands (left and right of the carrier). This equation gives the bandwidth which contains 98% of the signal power. This equation states that the FM signal bandwidth is twice the sum of the maximum frequency deviation and the modulating frequency. This equation is called *Carson's Rule*. For FM voice, the modulation frequency f_m is the maximum baseband (audio) frequency. Thus, when the number of

sidebands transmitted is $1+\beta$ on each side of the carrier, it has been shown mathematically based on the Bessel Functions that 98% of the power is transmitted.

5.5.2 Performance

5.5.2.1 FM Threshold

The *FM threshold* is a point on the curve of output S/N vs. input S/N at which the curve changes dramatically. Above threshold, the input vs. output S/N relationship is linear. Below threshold, the output S/N falls off faster than the input S/N.

The threshold value is arbitrarily defined to be the value of input S/N for which the output S/N is 1 dB lower than the linear value. When the input S/N falls below this point, the system should be considered unusable. The threshold increases with an increase in the modulation index. Even though a large modulation index results in improved performance above threshold, this improvement comes with the price of a relatively higher threshold.

Clearly, it is desirable for an FM receiver to have as low a threshold as possible. However, lowering the threshold implies a reduction in modulation index, which in turn deprives the system of the improved output S/N that a larger modulation index provides. System designers exploit these dependencies to tailor FM systems for particular applications. A system with a low modulation index – β equal to 0.5 or 0.6, for example – will have a low threshold, enabling it to be used in conditions of marginal reception. This property may be important for tactical communications, where the low threshold is more important than high fidelity. On the other hand, a system with a larger modulation index will be capable of higher fidelity, but at the expense of a higher threshold. This trade-off may make sense for commercial FM systems that compete for listeners based, in part, on high-fidelity programs.

The threshold for a particular system depends on more than the modulation index. There are several techniques available to designers for implementing FM demodulators. These implementations have some bearing on the point at which threshold occurs. The most reliable way to determine the threshold of an FM demodulator is by measurement. Along with the sensitivity, the threshold of an FM receiver should be part of the system specifications.

FM systems that are designed for low threshold operation are often called narrowband systems. Since these systems have relatively low modulation indices, they also require relatively small operating bandwidths. Systems designed for high-fidelity operation are often called wideband systems. These systems have relatively large modulation indices, and require correspondingly large operating bandwidths.

5.5.2.2 Narrowband Interference and Narrowband FM

Narrowband interference may simply be due to signals from narrowband transmitters in the receiver environment. The self-interference due to multipath propagation in built-up areas – commonly referred to as fading – also tends to be narrowband in nature.

Narrowband FM addresses these interference types in two ways. By maintaining a low threshold, narrowband FM offers more operating margin than wideband FM. Moreover, since narrowband FM means less channel bandwidth, there are likely to be more available channels from which a non-degraded channel can be selected.

5.5.2.3 Pre-emphasis and De-emphasis

An FM system makes the best use of its operating bandwidth when the spectrum of the modulating signal is flat. An FM system can make it flat by applying a filter with the appropriate transfer function. This process is referred to as *pre-emphasis*. The demodulator cancels the effect of pre-emphasis by applying a filter with the complementary transfer function. This process is called *de-emphasis*. The success of this technique depends on a prior knowledge of the modulating signal spectrum.

Pre-emphasis and de-emphasis can improve the output S/N by 5 or 6 dB in some cases. This improvement should be interpreted as bringing a system closer to its optimum operating specification. If an FM system uses this technique, it is very likely that the sensitivity specification already includes the adjustment.

5.5.2.4 Capture Effect

The capture effect can be explained with the case of two co-channel or adjacent channel FM signals being received at the same time by an FM receiver. When the two FM stations are on the same frequency, the FM receiver will lock-onto or “capture” the stronger signal and ignore or suppress the weaker. The amplitude limiter in the receiver will tend to suppress the weaker signal. The FM receiver will treat the weaker signal as interference and the stronger signal is said to have captured the receiver. When the two input signals are of nearly equal strengths, the receiver fluctuates back and forth between them. If the interfering signal is stronger than the desired signal, the FM receiver will lock onto the interfering signal. This phenomenon is called “*capture effect*”.

5.5.3 Transfer Function

For an FM demodulator operating above FM threshold with noise (or noise-like interference), the output S/N is related to the input S/N as follows:

$$\left(\frac{S}{N}\right)_{\text{out}} = \left(\frac{S}{N}\right)_{\text{in}} + 10 \log\left(\frac{3}{2}\beta^2\right) \quad (5-11)$$

where

$(S/N)_{\text{out}}$ = output signal-to-noise power ratio, in dB

$(S/N)_{\text{in}}$ = input signal-to-noise power ratio, in dB

β = modulation index of the demodulator, unitless

This expression demonstrates a fundamental property of FM – the ability to improve the output S/N by increasing the modulation index. Since an increase in modulation index corresponds to an increase in maximum frequency deviation, this improvement necessitates an increase in bandwidth.

For a narrowband FM demodulator operating above threshold with narrowband FM interference, simulations show the transfer function to be:

$$\left(\frac{S}{N}\right)_{\text{out}} = \left(\frac{S}{N}\right)_{\text{in}} + 5 \quad (5-12)$$

The output S/N is related to the input S/N by a generalized formula as follows:¹³

$$\left(\frac{S}{N}\right)_{\text{out}} = \frac{(3/2)\beta^2\left(\frac{S}{N}\right)_{\text{in}}}{1+(12\beta/\pi)\left(\frac{S}{N}\right)_{\text{in}} \exp\left\{-1/2[1/(\beta+1)]\left(\frac{S}{N}\right)_{\text{in}}\right\}} \quad (5-13)$$

5.5.4 AI Curves

Figure 5.5-1 and Figure 5.5-2 show AI curves for an FM voice receiver. In these graphs, the term “interference” and the variable I refer to non-noise-like interference. Any noise-like interference power is simply assumed to be added (in mW) to the noise power. For example, suppose there are two interfering signals: an ASK signal and a noise-like signal. The S/I parameter is the ratio of the desired signal power to the ASK interfering signal power, and the x-axis variable S/N is the ratio of the desired signal power to the total noise-like power (including the receiver noise and the noise-like interfering signal).

The curves were generated by time-domain simulation. The IF bandwidth was 16 kHz. The audio (baseband) bandwidth was from 300 Hz to 3.5 kHz. The peak frequency deviation was 5 kHz. These parameters imply a modulation index of $\beta = 5/3.5 = 1.4$. Note that the IF bandwidth is slightly smaller than the $2(5 + 3.5) = 17$ kHz specified by Carson’s rule. Pre-emphasis and de-emphasis were not included in the receiver model. In the last part of the simulation, the signals were transformed to the frequency domain for calculating the AI, as described in Section 5.2.1.

Figure 5.5-1 shows AI curves for an FM voice receiver with ASK interference. In the simulation, the ASK interfering signal had a bit rate of 100 bps and was on-tune with the receiver. There are six curves displayed. Each curve is a plot of AI vs. S/N. The top curve (labeled “No interference”) applies to the case in which there is no ASK interference. The other five curves are for cases with ASK interference. Each of those five curves is labeled with the S/I for that curve. As expected, each curve shows that the intelligibility (as indicated by the AI) improves as the S/N increases. As also expected, for a given S/N the intelligibility improves as the S/I increases.

Figure 5.5-2 shows AI curves for an FM voice receiver with FSK interference. In the simulation, the FSK interfering signal had a bit rate of 50 bps and an off-tuning of 500 Hz, but other simulations showed the results to be insensitive to the bit rate and to variations of off-tuning within the same frequency channel. The frequency deviation of the FSK signal was ± 200 Hz.

¹³ H. Taub and D. L. Schilling. *Principals of Communication Systems*. McGraw-Hill. 1971.

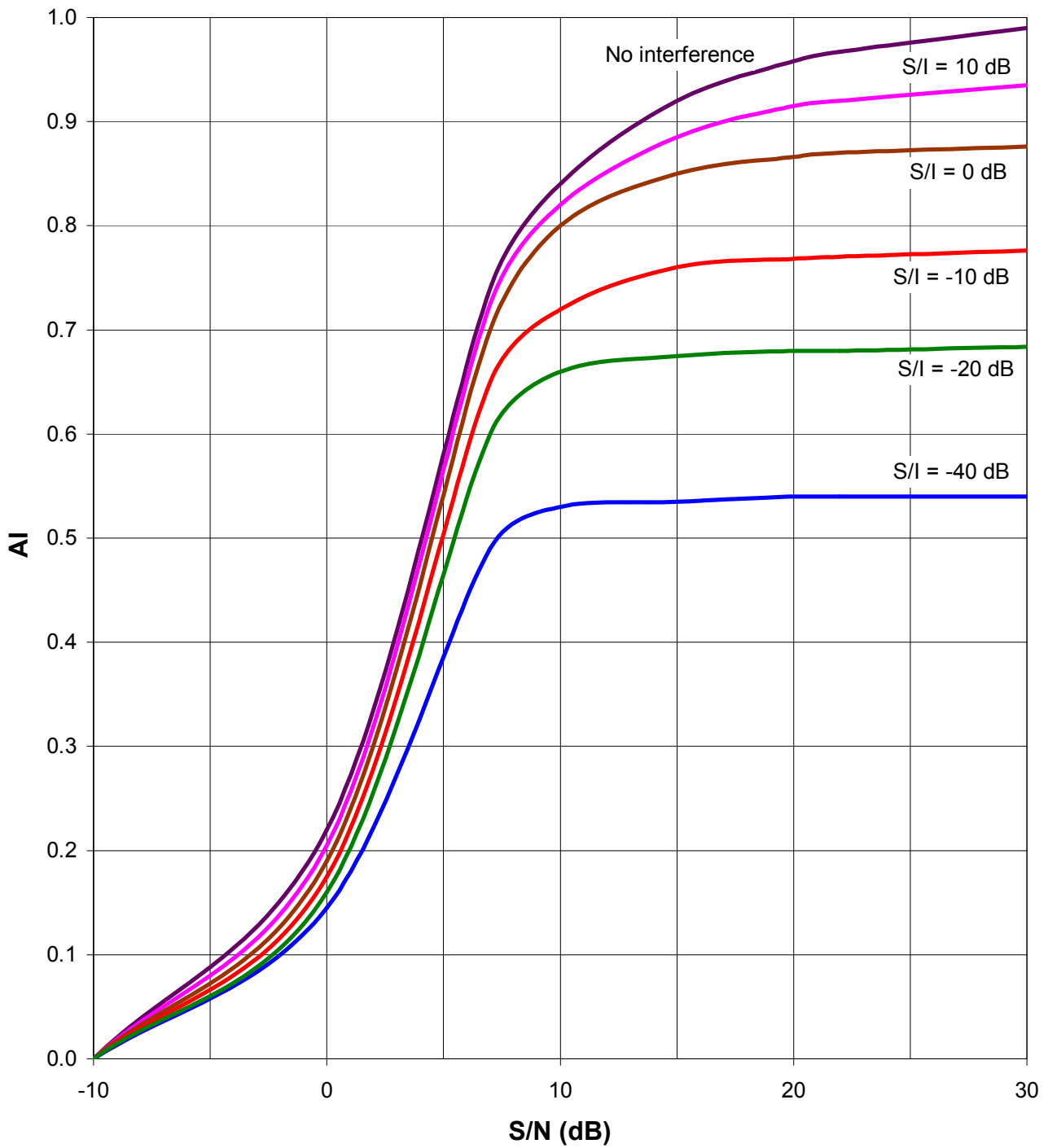

Figure 5.5-1. AI vs. $(S/N)_{in}$ Curves for FM Voice Receiver with ASK Interference

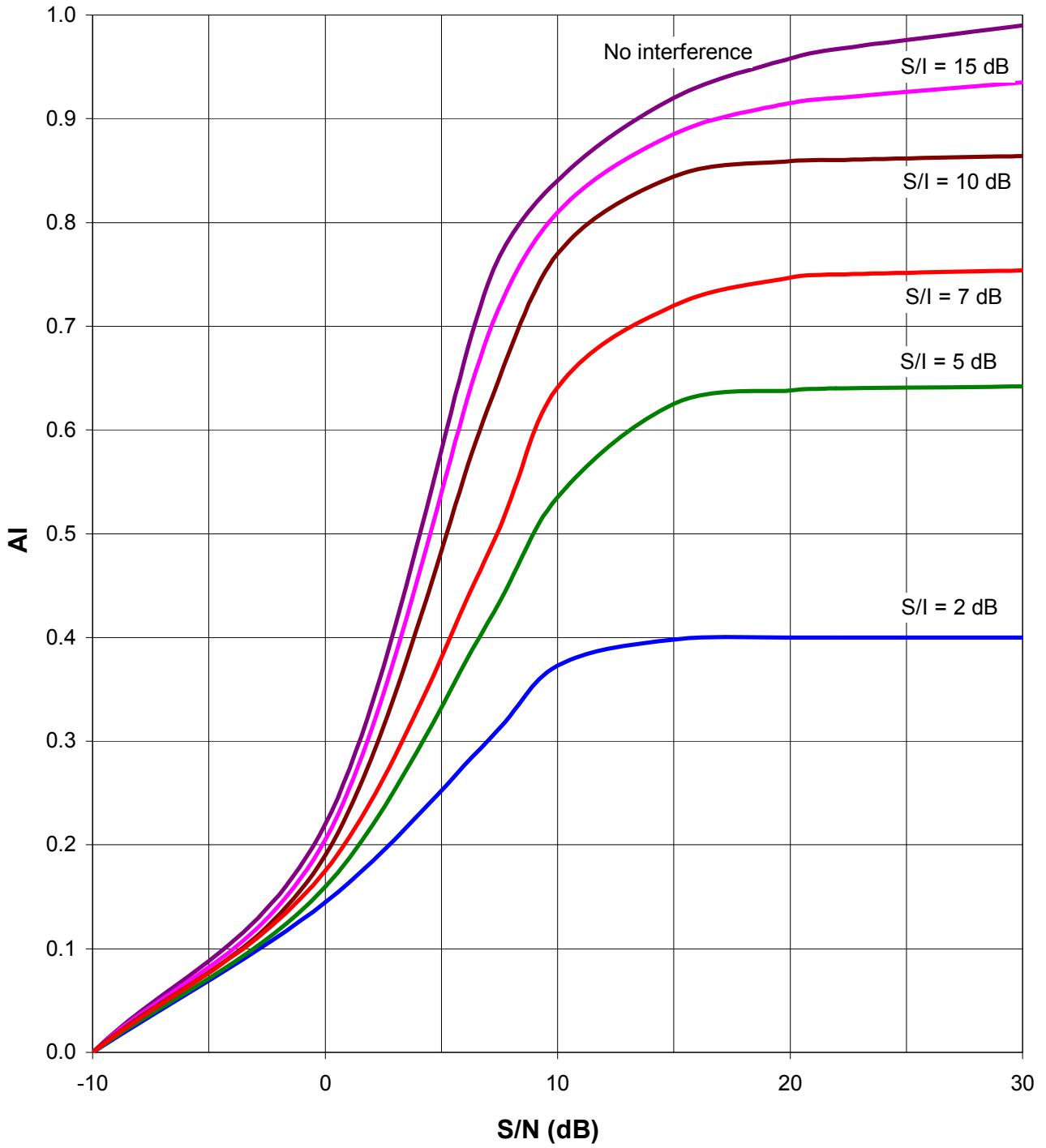

Figure 5.5-2. AI vs. $(S/N)_{in}$ Curves for FM Voice Receiver with FSK Interference

5.5.5 FM Voice Co-Channel and Adjacent Channel Interference Analysis

5.5.5.1 Analytical Formulations

FM voice performance in a thermal noise environment was described mathematically in Section 5.5.3. This section expands upon that derivation and examines FM voice performance in the presence of thermal noise and interference.

Figure 5.5-3 provides a block diagram overview of an FM voice receiver in a thermal noise and interference environment.

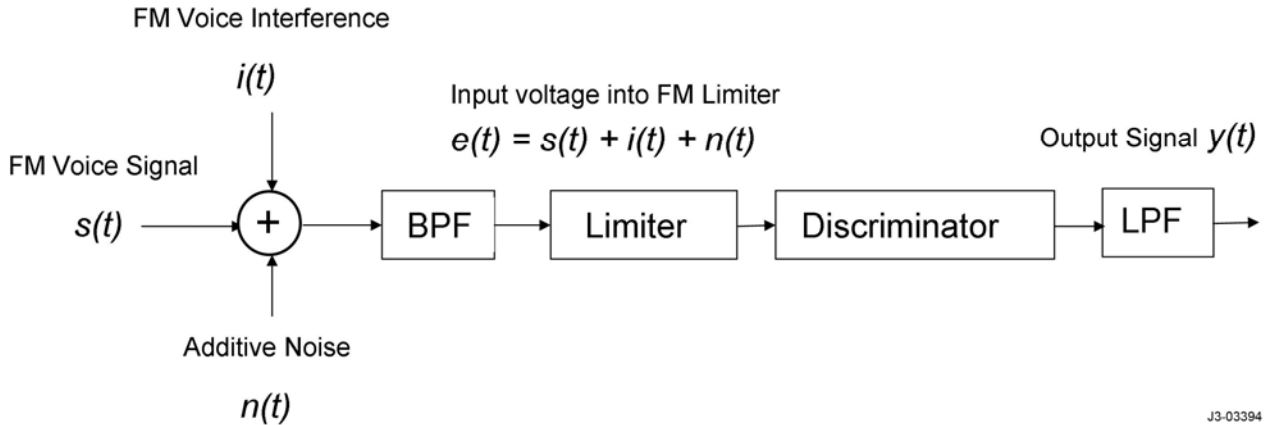

Figure 5.5-3. FM Voice Receiver Block Diagram

Input voltage into the FM Limiter is given by $e(t) = s(t) + i(t) + n(t)$, and the output signal at the filter output is given by $y(t)$. Where $s(t)$ is a “FM voice signal,” $i(t)$ is “FM voice interference,” and $n(t)$ is “additive noise.”

Analytical equations are helpful for MATLAB/Simulink simulation validation efforts where considerable validation steps are needed. The methodology follows that of Prabhu and Enloe,¹⁴ and is developed by William Jakes¹⁵ and A. Sheikh.¹⁶ The input to the FM detector is assumed to consist of the desired signal $s(t)$, and the interfering signal $i(t)$. The Gaussian noise from the receiver front-end is neglected in our co-channel calculations in order to keep the mathematics simple.

The signals are angle modulated so that

$$s(t) = \cos [wct + \varnothing(t) + \mu] \quad (5-14)$$

$$i(t) = R \cos [(wc + wd)t + \varnothing i(t) + \mu i] \quad (5-15)$$

where $f_c = w_c / 2\pi$ is the carrier frequency of the desired signal, and $f_d = w_d / 2\pi$ is the difference between the carrier frequency of the interfering signal and that of the desired signal.

¹⁴ V. K. Prabhu and L. H. Enloe. *Interchannel Interference Considerations in Angle Modulated Systems*. Bell System Technical Journal 48, No. 7, pp. 2333-2358. September 1969.

¹⁵ William C. Jakes. *Microwave Mobile Communications*. IEEE Press. 1993.

¹⁶ Asrar Sheikh. *Wireless Mobile Communications: Theory and Techniques*. Kluwer Academic Publishers. 2003.

For co-channel interference f_d is usually small, but if it is large enough to pass through the baseband filter, the offset f_d can have a strong effect. $\theta(t)$ is the phase modulation of the desired signal while $\theta_i(t)$ is that of the interfering signal, and μ and μ_i are the phase angles of the desired and interfering signals, respectively. R is the amplitude of the interfering signal relative to that of the desired signal.

The total voltage into the FM detector is then given by

$$e(t) = \text{Re} \{ [\exp [j(\theta(t) + \mu)] + R \exp [j(\omega_d t + \theta_i(t) + \mu_i)]] e^{j\omega_c t} \}$$

$$e(t) = \text{Re} \{ [\exp [j(\theta(t) + \mu)] \times [1 + R \exp [j(\omega_d t + \theta_i(t) - \theta(t) + \mu_i - \mu)]]] e^{j\omega_c t} \} \quad (5-16)$$

For a detailed mathematical analysis, the reader is referred to Jakes where a thorough treatment of the baseband co-channel and adjacent channel interference is presented. The analytical derivations and approximations are used to validate the MATLAB/Simulink simulations in the calculation of $[S/N]_{\text{out}}$, $[S/I]_{\text{out}}$ and $[S/(N+I)]_{\text{out}}$.

5.5.5.2 FM Voice S/(N+I) and AI Simulations

Simulations are performed in two steps:

- i. **Calculation of baseband S/(N+I)** - as shown by the FM Voice Receiver Block Diagram in Figure 5.5-3, MATLAB/Simulink simulation models have been generated to calculate the baseband output S/I, S/N and S/(N+I). Analytical formulations of S/N and available plots (see Jakes reference 15) of S/I are utilized to validate simulation steps. The FM voice interferer signal has the same signal characteristics as the desired signal.
- ii. **Calculation of AI** - AI is then calculated using Equation 5-1 and Table 5.2-1 data, based on the methodology described in Section 5.2.1

Figure 5.5-4 and Figure 5.5-5 show AI curves for an FM voice receiver, for co-channel and adjacent-channel FM voice interference, respectively. These curves were generated by Simulink simulations using the methodology described in Section 5.2.1.

The parameters and assumptions are similar to those used in generating Figures 5.5-1 and 5.5-2. In these graphs, the term “interference” and the variable I refer to non-noise-like interference. Any noise-like interference power is simply assumed to be added (in mW) to the noise power. For example, suppose there are two interfering signals: an FM signal and a noise-like signal. The S/I parameter is the ratio of the desired signal power to the FM interfering signal power, and the x-axis variable S/N is the ratio of the desired signal power to the total noise-like power (including the receiver noise and the noise-like interfering signal).

The curves were generated by time-domain simulation using Simulink. The audio (baseband) bandwidth was from 176.78 Hz to 5656.85 Hz. The peak frequency deviation Δf was set to 8 kHz. These parameters imply a modulation index of $\beta = \Delta f / f_m = 8 / 5.5656 = 1.414$ (see Equation 5-9). The bandwidth of the FM voice signal as defined by Carson’s law from Equation 5-10 is $B = 2(\Delta f + f_m) = 2 * (8 + 5.656) = 27.3$ kHz. In the last part of the simulation, the signal and noise were transformed to the frequency domain to calculate S/N and hence the AI, as described in Section 5.2.1.

Figure 5.5-4 shows AI curves for an FM voice receiver with co-channel FM voice interference. Each curve is a plot of AI vs. S/N. The top curve (labeled “No interference”) applies to the case in which there is no interference. The other five curves are for cases with co-channel FM voice interference. Each of those five curves is labeled with the S/I for that curve. As expected, each

curve shows that the intelligibility (as indicated by the AI) improves as the S/N increases. As also expected, for a given S/N the intelligibility improves as the S/I increases. It should be noted that “No Interference” AI values are different than those of Figure 5.5-1 and Figure 5.5-2 due to different sets of assumptions and wider FM bandwidth.

Figure 5.5-5 shows AI curves for an FM voice receiver with adjacent-channel FM voice interference off-tuned by 25 kHz. The FM parameters are assumed to be the same for both emissions. Each curve is a plot of AI vs. S/N. The top curve (labeled “No interference”) applies to the case in which there is no interference. The other five curves are for cases with adjacent-channel FM voice interference. Each of those five curves is labeled with the S/I for that curve. As expected, each curve shows that the intelligibility (as indicated by the AI) improves as the S/N increases. As also expected, for a given S/N the intelligibility improves as the S/I increases.

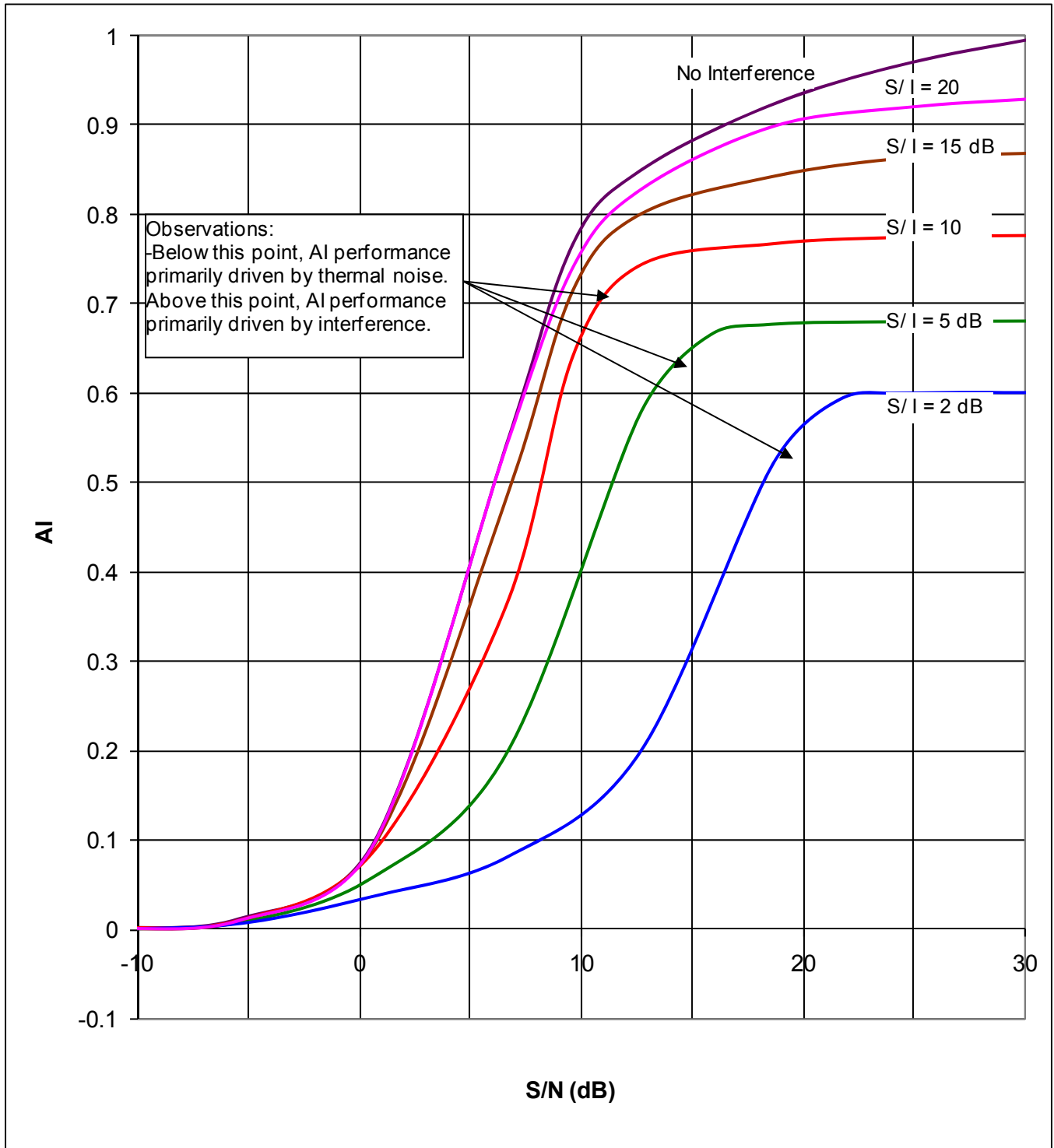

Figure 5.5-4. AI vs. $(S/N)_{in}$ Curves for FM Voice Receiver with Co-Channel FM Voice Interference

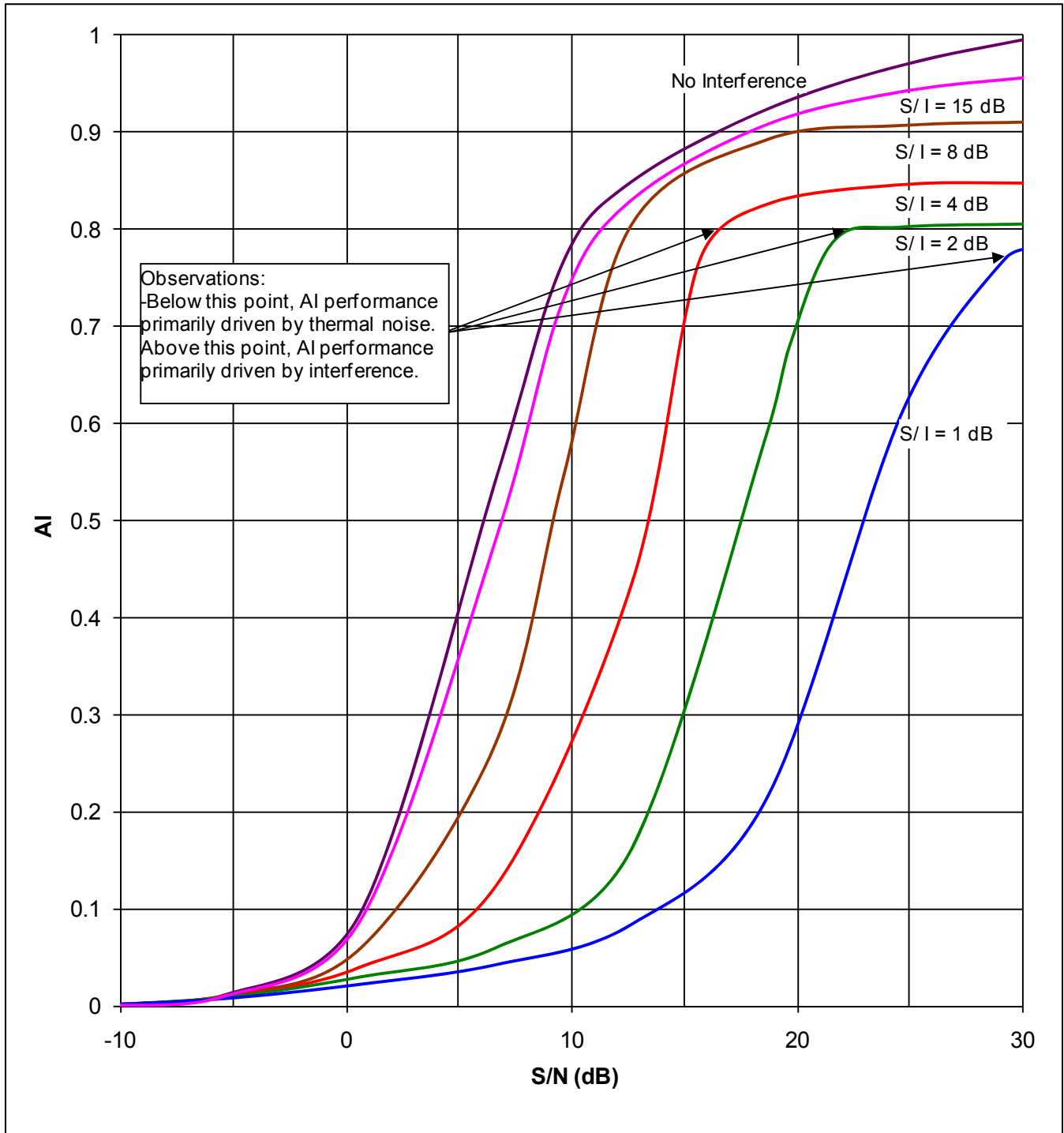

Figure 5.5-5. AI vs. $(S/N)_{in}$ Curves for FM Voice Receiver with Adjacent-Channel FM Voice Interference

5.6 BROADCAST VIDEO TRANSMISSION

5.6.1 Description

Vestigial sideband AM (with the carrier, one complete sideband, and a small portion of the other sideband) is used exclusively for broadcast video transmission. Since the output is a combination of

sound and picture, a single S/N value is inadequate to measure the receiver performance. For television receivers, it is common to specify the required performance subjectively. By experimentation, the subjective measurements can be related to the input S/N. In the TASO scoring procedure, observers are asked to rate picture quality on a scale of 1 to 6 as shown in Table 5.6-1.

Table 5.6-1. TASO Score Definition

TASO Score	Name	Description
1	Excellent	The picture is of extremely high quality, as good as you could desire.
2	Fine	The picture is of high quality providing enjoyable viewing. Interference is perceptible.
3	Passable	The picture is of acceptable quality. Interference is not objectionable.
4	Marginal	The picture is poor in quality and you wish you could improve it. Interference is somewhat objectionable.
5	Inferior	The picture is very poor but you could watch it. Definitely objectionable interference is present.
6	Unusable	The picture is so bad that you could not watch it.

5.6.2 TASO Curves

Figure 5.6-1 shows TASO curves for an analog broadcast video transmission receiver. There are three curves, one for each type of interference: ASK, noise-like, and video transmission interference. Each curve is a plot of TASO score vs. input S/I. As expected, each curve shows that the picture quality (as indicated by the TASO score) improves as the S/I increases. The curves were generated by collecting responses from a viewer panel.¹⁷ The receiver was a standard US commercial video receiver with an IF bandwidth of 5 MHz. The ASK interfering signal had a bit rate of 100 bps and was on-tune with the receiver. The interfering video transmission signal was also on-tune with the receiver.

¹⁷ H. Fine. *A Further Analysis of TASO Panel 6 Data on Signal-to-Interference Ratios and Their Application to Description of Television Service*. T.R.R. Report No. 5.1.2, Washington, DC: FCC. 1 April 1960.

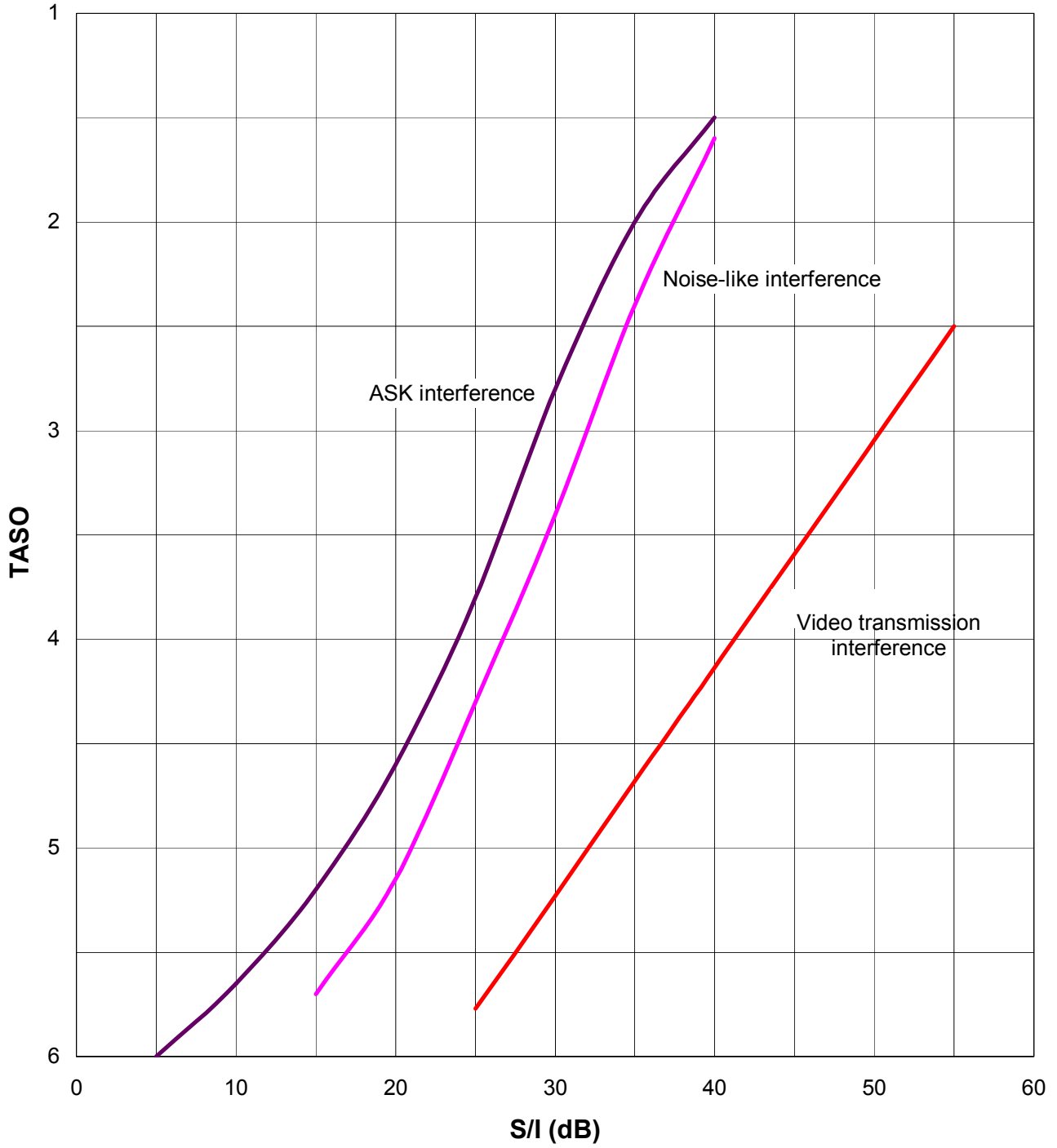

Figure 5.6-1. TASO Score vs. $(S/I)_{in}$ Curves for Broadcast TV Receiver

This page intentionally left blank.

SECTION 6 - DIGITAL DEMODULATOR

This section describes the demodulator model for digital receivers. Performance measures for digital demodulators are discussed. The ratio of bit energy to noise power density (E_b/N_o) is defined. Transfer functions that relate output error rate to input E_b/N_o for noise-like interference are presented. Curves that specify output BER as a function of E_b/N_o and S/I are also provided.

In digital communication systems, we are primarily interested in energy per bit to noise plus interference power density ratio $E_b/(N_o+I_o)$. *When assessing link performance*, $E_b/(N_o+I_o)$ is a commonly used Figure-of-Merit rather than E_b/N_o alone, because it takes interference effects into account. Thus, the equivalent $E_b/(N_o+I_o)$ is used to determine the overall link QoS and enhance the margin against the target BER performance. For example, “the overall calculated $E_b/(N_o+I_o)$ is compared to the required $E_b/(N_o+I_o)$ for the specific BER depending upon the waveform modulation and coding employed. Thus, the effective $E_b/(N_o+I_o)$ can be referred to as the *”Link Performance Figure-of-Merit.”*

It should be noted that the effective N_o as part of the E_b/N_o (x-axis) in the curves presented in this section is considered to be due to receiver system noise density and AWGN-like interference. The interference “I” associated with S/I is not included in the effective “ N_o ” calculation. In general, link budgets assess the link performance in terms of the total $E_b/(N_o + I_o)$ where I_o accounts for interference due to all sources whether noise-like or not (such as adjacent channel interference, code noise, intermodulation, external interference from various other sources, etc.).

It should also be noted that calculating $E_b/(N_o+I_o)$ is only possible if one is able to accurately express the interferer in terms of a flat density. One of the main benefits of this Handbook is that the interference typically does not nicely fit to an I_o . We specifically address those cases in this Handbook.

The users will however make use of these curves by selecting the BER vs. E_b/N_o curve at a specific S/I to assess link performance. If a specific S/I is used in the referenced BER vs. E_b/N_o curves, then an interpolation can be performed. Thus, these curves will help the user evaluate link performance under various S/I scenarios and in the presence of noise like additive interference.

6.1 INTRODUCTION

The purpose of the digital demodulator is to reconstruct the digital data that was used to modulate the carrier. In some cases, this digital data is a digitized audio or video waveform. The three carrier properties most commonly modified in the modulation process are phase, frequency, and amplitude. There are several properties of digital RF systems that affect system performance:

Power Spectral Density and Bandwidth. The bandwidth required for a digital communication system depends primarily on the data rate and the modulation type. It may be assumed that the data modulating the carrier is random.

Since the data is random, the modulated signal constitutes a stochastic process. This process can be characterized in the time domain by the autocorrelation function, which is calculated from the statistics of the modulated signal. The Fourier transform of the autocorrelation function is called the PSD of the modulated signal. The PSD at a given frequency is the power per unit bandwidth (e.g., in W/Hz) at that frequency.

Measurements and calculations of the PSD for digital signals show that the signal bandwidth is nominally equal to the bit rate or symbol rate. However, the precise bandwidth and spectral shape depends on the type of modulation. Some modulation types are quite spectrally efficient. The indiscriminate use of bandpass filtering to reduce the signal bandwidth is not practical, because a narrow filter bandwidth will distort the signal.

Susceptibility to Noise and Interference. The susceptibility depends on the modulation type. A coherent demodulator generates a local waveform that is in phase with the received signal. Although it is more difficult and costly to implement than the noncoherent demodulator, it decreases susceptibility to noise and interference. Other modulation characteristics, such as the carrier property modulated (e.g., phase), also affect the susceptibility. As expected, performance is best for any modulation type when the desired signal power is significantly higher than the noise and interference power. Unlike analog demodulators, digital demodulators exhibit a transition from unacceptable to virtually error-free performance over a relatively small range of input values.

Synchronization and Threshold. Digital demodulators require some level of synchronization to operate properly. At the very least, the demodulator must be able to identify the data bit boundaries. Additional levels of synchronization may also be required, since digital data is often organized into symbols, frames, packets, or other multi-bit structures.

Synchronization algorithms in the receiver are designed to be particularly robust. Therefore, the required S/N for message transmission (in steady interference conditions) is usually also adequate for maintaining synchronization. If synchronization is lost for some reason – perhaps due to an interference pulse – it may be necessary to estimate the time needed to regain synchronous operation. If this time is not provided as part of the system specification, it is best determined by measurement or simulation.

All digital communication receivers require some degree of synchronization to the incoming signal. Synchronization in a communication system can take the form of:

- Phase / frequency synchronization (by use of Phase-Locked-Loop)
- Data symbol synchronization (essential to achieve optimum demodulation)
- Frame synchronization.
- PN sequence synchronization.

Receiver complexity to achieve synchronization varies whether it employs open-loop or closed loop design. The chosen synchronization technique also depends on the application (spread spectrum, etc).

Soft Decision Demodulation. For a given received digital symbol waveform, a demodulator may make a definite decision as to which symbol is associated with that waveform. The output of this hard-decision demodulator is a sequence of symbol values. In contrast, the output of a soft-decision demodulator is a sequence of likelihood values. Each soft-decision value indicates the likelihood that a given symbol was sent, and a subsequent error correction device uses that likelihood to make a decision. Section 6 considers only hard-decision demodulators. For soft-decision systems, the demodulator and FEC decoder are treated as one combined module in Section 7.

6.2 BINARY SYSTEMS

In binary digital communications systems, the data can be represented as an information sequence consisting of binary digits (bits). Prior to modulation, additional bits may be added for error correction, synchronization, etc. Each bit has one of two possible values (0 or 1) and is associated with a distinct waveform. Consequently, bits have several properties that derive from their waveform representation:

- The bit duration T_b is the duration of the waveform associated with each bit.
- The bit rate (or data rate) R_b is the number of bits transmitted per second.
- The bit energy E_b at a given point in the system is the energy in the bit waveform at that point.

The bit rate and bit duration are related by:

$$R_b = \frac{1}{T_b} \quad (6-1)$$

where

$$\begin{aligned} R_b &= \text{bit rate, in bits/s or Hz} \\ T_b &= \text{bit duration, in s} \end{aligned}$$

The bit energy is related to the signal power S by:

$$E_b = ST_b \quad (6-2)$$

where

$$\begin{aligned} E_b &= \text{bit energy, in J} \\ S &= \text{signal power, in W} \end{aligned}$$

Noise within the receiver is assumed to have, at its point of origin, a constant power density at all frequencies. At the demodulator input, the total noise power is given by:

$$N = N_o B \quad (6-3)$$

where

$$\begin{aligned} N &= \text{noise power at the demodulator input, in W} \\ N_o &= \text{one-sided noise power density at the demodulator input, in W/Hz} \\ B &= \text{narrowest filter bandwidth preceding the demodulator, in Hz.} \end{aligned}$$

Based on the previous definitions, the ratio of bit energy to noise power density is given by:

$$\frac{E_b}{N_o} = \frac{ST_b}{N/B} = \frac{S}{N} \frac{B}{R_b} \quad (6-4)$$

Just prior to making a decision on a given bit, the demodulator integrates all the power in the bit waveform. This action equivalently filters the signal with a bandwidth R_b , which is the signal bandwidth. If B exceeds R_b , then this operation improves the S/N by the factor B/R_b . Thus E_b/N_o can

be viewed as an improved S/N (at the input to the decision circuit). In many cases, B is equal to the bit rate and E_b/N_o is equal to the S/N at the demodulator input.

For each bit the demodulator must decide, based on the received signal, which of the two possible waveforms was transmitted. The waveforms are designed to be different enough that the correct decision will be made most of the time, even though the received signal has been degraded by the propagation environment. The standard measure of performance for the demodulator is the probability of bit error, commonly referred to as the BER. Analytical expressions for the BER as a function of E_b/N_o are available for many digital demodulators, and are included in this section.

Similarly, it can be shown that

$$\frac{E_b}{I_o} = \frac{ST_b}{I/B} = \frac{S}{I} \frac{B}{R_b} \quad (6-5)$$

where

- I = Interference power at the demodulator input, in W
- I_o = Interference power density at the demodulator input, in W/Hz

The ratio of bit energy to [noise power density + interference power density], $E_b/(N_o+I_o)$, is then obtained from

$$E_b/(N_o+I_o) = [(E_b/N_o) - 1 + (E_b/I_o) - 1] - 1 \quad (6-6)$$

where the effective $E_b/(N_o+I_o)$ is referred to as the "Link Performance Figure-of-Merit." This assumes the interference is inherently noise-like.

6.3 M-ARY SYSTEMS

In some digital communications systems, the bits are converted into multi-bit symbols prior to modulation. Each symbol has one of M possible values (0, 1, 2, ..., $M-1$) and is associated with a distinct waveform. Consequently, symbols have several properties that derive from their waveform representation:

The symbol duration T_s is the duration of the waveform associated with each symbol.

The symbol rate R_s is the number of symbols transmitted per second.

The symbol energy E_s at a given point in the system is the energy in the symbol waveform at that point.

The number of possible symbols is given by:

$$M = 2^k \quad (6-7)$$

where

- M = number of possible symbols
- k = number of bits per symbol

A system in which $k = 1$ and $M = 2$ is referred to as binary (Section 6.2). If $k > 1$, the system is referred to as M -ary. For example, an 8-ary system has three bits per symbol and $M = 2^3 = 8$. The possible symbol values are 0, 1, 2, 3, 4, 5, 6, 7 and each of those values is associated with a distinct waveform.

Equations 6-1, 6-2, and 6-4 can be generalized to the M-ary case:

$$R_s = \frac{1}{T_s} \quad (6-8)$$

$$E_s = ST_s \quad (6-9)$$

$$\frac{E_s}{N_o} = \frac{ST_s}{N/B} = \frac{S}{N} \frac{B}{R_s} \quad (6-10)$$

Just prior to making a decision on a given symbol, the demodulator integrates all the power in the symbol waveform. This action equivalently filters the signal with a bandwidth R_s , which is nominally equal to the bandwidth of the desired signal. If B exceeds R_s , then this operation improves the S/N by the factor B/R_s . Thus, as in the binary case, E_s/N_o can be viewed as an improved S/N (at the input to the decision circuit). In many cases, B is equal to the symbol rate and E_s/N_o is equal to the S/N at the demodulator input.

For each symbol the demodulator must decide, based on the received signal, which of the M possible waveforms was transmitted. The standard measure of performance for the demodulator is the probability of symbol error, commonly referred to as the SER. Analytical expressions for the SER as a function of E_s/N_o are available for many digital demodulators, and are included in this section.

6.4 M-ARY SYSTEM PERFORMANCE IN BINARY TERMS

It is often convenient to express the performance of an M -ary system in binary terms; i.e., in terms of BER and E_b/N_o instead of SER and E_s/N_o . This facilitates the performance evaluation of a demodulator by always expressing the input and output parameters in terms of the fundamental data unit – the bit.

Because there are k bits per symbol, the duration of a symbol (T_s) is k times the duration of a bit (T_b). Equations 6-2 and 6-9 can then be combined to give:

$$\frac{E_s}{N_o} = \frac{ST_s}{N_o} = \frac{SkT_b}{N_o} = k \frac{E_b}{N_o} \quad (6-11)$$

The E_b/N_o and E_s/N_o ratios are usually given in dB, in which case Equation 6-9 takes the form:

$$\left[\frac{E_s}{N_o} = \frac{E_b}{N_o} + 10 \log(k) \right]_{\text{dB}} \quad (6-12)$$

The relationship between BER and SER is not so simple. Because there are k bits per symbol, a particular symbol error may result in only one bit error or as many as k bit errors (depending on which incorrect symbol was chosen). There are two common situations that occur.

In the first situation, the M waveforms are orthogonal in signal space. An example is 8-ary FSK, for which 8 waveforms can be treated as 8 orthogonal vectors in an 8-dimensional vector space. Each dimension is an independent frequency channel. This means that a random noise burst can occur with equal likelihood in any channel. Therefore, all incorrect symbols are equally likely to be chosen. In this case, the average number of bit errors (averaged over all possible incorrect symbol choices) can be calculated. The relationship between BER and SER is given by:

$$BER = \left(\frac{M/2}{M-1} \right) SER \tag{6-13}$$

For example, the BER for an 8-ary FSK system would be 4/7 of the SER.

In the second situation, the M waveforms are not orthogonal in signal space. An example is 8-ary PSK, for which 8 waveforms exist in a 2-dimensional vector space. In this situation, incorrect symbols adjacent to the correct symbol are more likely to be chosen. In many such cases, the assigning of waveforms to symbols can be done so that adjacent symbols differ by only one bit. In these cases, a symbol error corresponds to one bit error and $k-1$ correct bits, so that

$$BER = \frac{SER}{k} \tag{6-14}$$

For example, the BER for an 8-ary PSK system would be 1/3 of the SER.

If the noise and interference levels are high, then non-adjacent symbols may be chosen. Figure 6.4-1 shows an analytical performance curve for 8-ary PSK, obtained by calculating the SER with an analytic equation and then using Equation 6-14. The corresponding simulation curve is also shown. Note that when the BER exceeds 0.2, Equation 6-14 is inaccurate (because of non-adjacent symbol choices).

Equations 6-13 and 6-14 constitute upper and lower bounds, so that in general

$$\frac{SER}{k} \leq BER \leq \left(\frac{M/2}{M-1} \right) SER \tag{6-15}$$

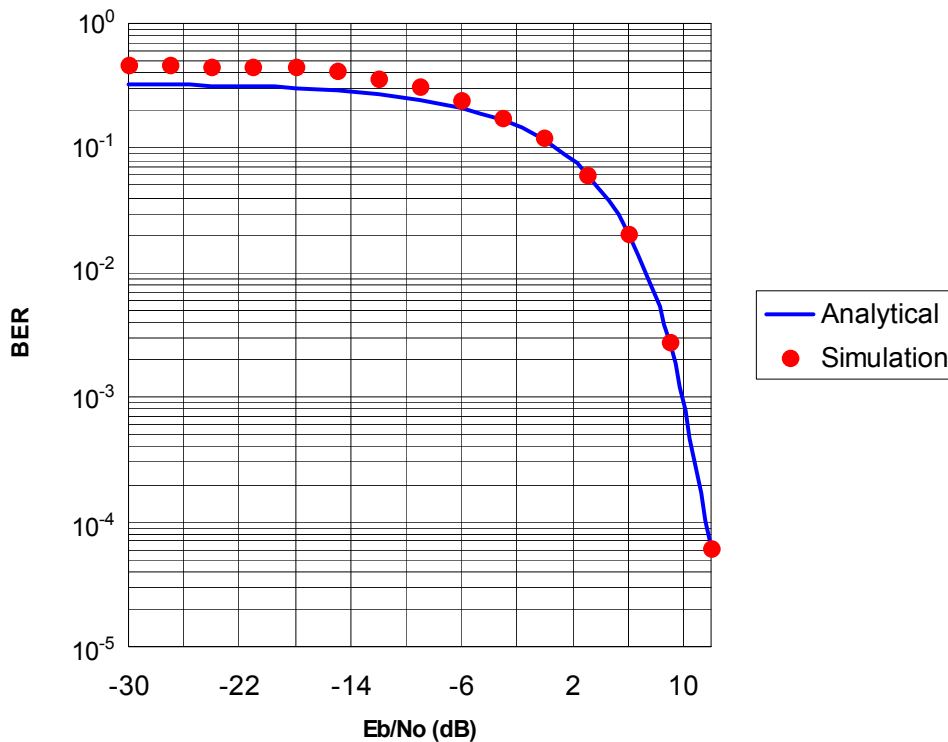

Figure 6.4-1. Analytical and Simulation BER Curves for PSK Receiver with $M = 8$

6.5 TYPES OF INTERFERENCE

Section 3.3.3 presents a case in which interference becomes noise-like when it passes through the RF/IF section. In that case, the interfering signal bit rate or chip rate exceeds that of the receiver, and the interfering signal bandwidth exceeds the receiver bandwidth. Thus broadband interference may become noise-like interference. To analyze its effect on performance, the noise-like interference power can simply be added (in W) to the other noise power within the receiver.

At the other extreme, a signal that theoretically has zero bandwidth is the single-frequency sinusoid, or CW signal. Narrowband interference may often be modeled as CW interference, because the performance is not sensitive to the specific details of the interference modulation. Because the CW signal is a simple, unmodulated signal, analytical expressions for BER for the case of noise and CW interference are available for some digital demodulators. In other cases for which a simulation must be performed, the use of a CW interfering signal simplifies the simulation.

For all performance curves presented in this section, only two types of interference are considered – noise-like and CW. This assumption permits the curves in the Handbook to be used in many practical cases with broadband and narrowband interference. If a continuous interfering signal is neither broadband nor narrowband, the effect on the BER will generally fall between that of CW interference and that of noise.

If an interfering signal is intermittent, the SER or BER will vary, and will therefore be less useful as a simple measure of performance. In this case, an analysis approach that considers the temporal properties of the interference should be devised (Section 3.4).

6.6 PHASE-SHIFT KEYING

The PSK characterized here assumes coherent reception. In coherent reception, the receiver regenerates the carrier from the received signal and then uses the regenerated carrier as a reference for determining the phase of the modulating signal. Noncoherent PSK is presented in Section 6.7.

6.6.1 Description

6.6.1.1 Binary PSK

Binary PSK (BPSK) is PSK with one bit per symbol ($k = 1$ and $M = 2$). The BPSK modulation represents logical 1 and logical 0 with two waveforms of the same frequency that are 180° out of phase. The voltage waveforms for 1 and 0 are:

$$v_1(t) = A \cos(2\pi f_c t) \quad (6-16)$$

$$v_0(t) = A \cos(2\pi f_c t + \pi) = -A \cos(2\pi f_c t) \quad (6-17)$$

where

A	=	amplitude, in V
f_c	=	carrier frequency, in Hz
t	=	time, in s

Alternatively, the waveforms may be expressed as the product of the modulating (baseband) signal and the RF carrier:

$$v(t) = b(t) A \cos(2\pi f_c t) \quad (6-18)$$

where

$$b(t) = 1 \text{ for logical 1 and } b(t) = -1 \text{ for logical 0.}$$

For noise and noise-like interference, the BER is given by:

$$BER = \frac{1}{2} \operatorname{erfc} \left(\sqrt{\frac{E_b}{N_o}} \right) \quad (6-19)$$

where

$\operatorname{erfc}(x)$ is the complementary error function.

6.6.1.2 Quadrature PSK

Quadrature PSK (QPSK) is PSK with two bits per symbol ($k = 2$ and $M = 4$). One of four possible waveforms is transmitted:

$$v(t) = A \cos \left(2\pi f_c t + i \frac{\pi}{2} \right) \quad (6-20)$$

where $i = 0, 1, 2,$ or 3 . The waveforms differ only in their phase. The phase angles are specified to have a uniform spacing of $\pi/2$ radians. Since there are four possible waveforms, it is possible to represent two bits of data per symbol.

The QPSK signal is essentially two binary PSK signals in phase quadrature. QPSK is a special $M > 2$ case in which an exact expression for the BER can be given. For noise and noise-like interference, the BER for QPSK is the same as for BPSK:

$$BER = \frac{1}{2} \operatorname{erfc} \left(\sqrt{\frac{E_b}{N_o}} \right) \quad (6-21)$$

The SER is given by:

$$SER = \left[\operatorname{erfc} \left(\sqrt{\frac{E_b}{N_o}} \right) \right] \left[1 - \frac{1}{4} \operatorname{erfc} \left(\sqrt{\frac{E_b}{N_o}} \right) \right] \quad (6-22)$$

6.6.1.3 M-ary PSK for $M > 4$

This is an extension of 2-phase and 4-phase modulation to the general case of M -phase modulation with k bits per symbol. One of M possible waveforms is transmitted:

$$v(t) = A \cos \left(2\pi f_c t + i \frac{2\pi}{M} \right) \quad (6-23)$$

where $i = 0, 1, 2, \dots, M-1$. The waveforms differ only in their phase. The phase angles are specified to have a uniform spacing of $2\pi/M$ radians.

For noise and noise-like interference, the SER for $M > 4$ is approximated by:

$$SER = \text{erfc} \left[\sqrt{k \frac{E_b}{N_o}} \sin \left(\frac{\pi}{M} \right) \right] \quad (6-24)$$

Thus, it follows from Equation 6-14 that

$$BER = \frac{1}{k} \text{erfc} \left[\sqrt{k \frac{E_b}{N_o}} \sin \left(\frac{\pi}{M} \right) \right] \quad (6-25)$$

6.6.2 BER Curves

6.6.2.1 BER Curves with CW Interference

Figures 6.6-1, 6.6-2, 6.6-3, and 6.6-4 show BER curves for a PSK receiver with $M = 2$, $M = 4$, $M = 8$, and $M = 16$, respectively. In these graphs, the terms “interference” and the variable I refer to CW interference. Any noise-like interference power is simply assumed to be added (in mW) to the noise power. For example, suppose there are two interfering signals: a CW signal and a noise-like signal. The S/I parameter is the ratio of the desired signal power to the CW interfering signal power, and the x-axis variable E_b/N_o is calculated with Equation 6-4, where N is the total noise-like power (including the receiver noise and the noise-like interfering signal).

The curves were generated from analytic expressions, including Equations 6-14, 6-19, 6-21, and 6-24. Analytic expressions for cases involving CW interference required numerical integration.

Each figure displays six curves. Each curve is a plot of BER vs. E_b/N_o . The curve labeled “No interference” applies to the case in which there is no CW interference. The other five curves are for cases with CW interference. Each of those five curves is labeled with the S/I for that curve. As expected, each curve shows that the BER decreases as the E_b/N_o increases. As also expected, for a given E_b/N_o the BER decreases as the S/I increases.

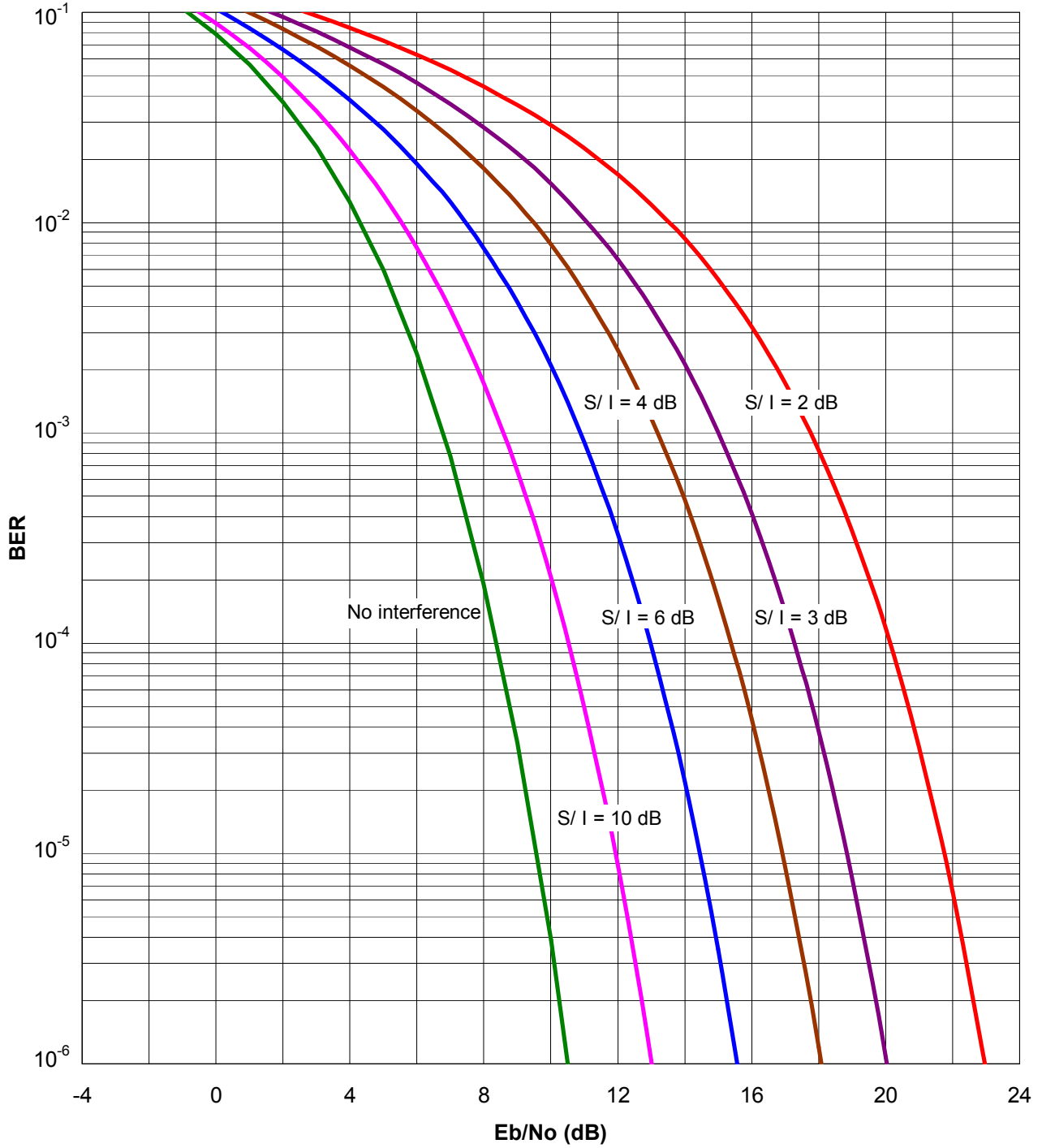

Figure 6.6-1. BER vs. E_b/N_o Curves for PSK Receiver ($M=2$) with CW Interference

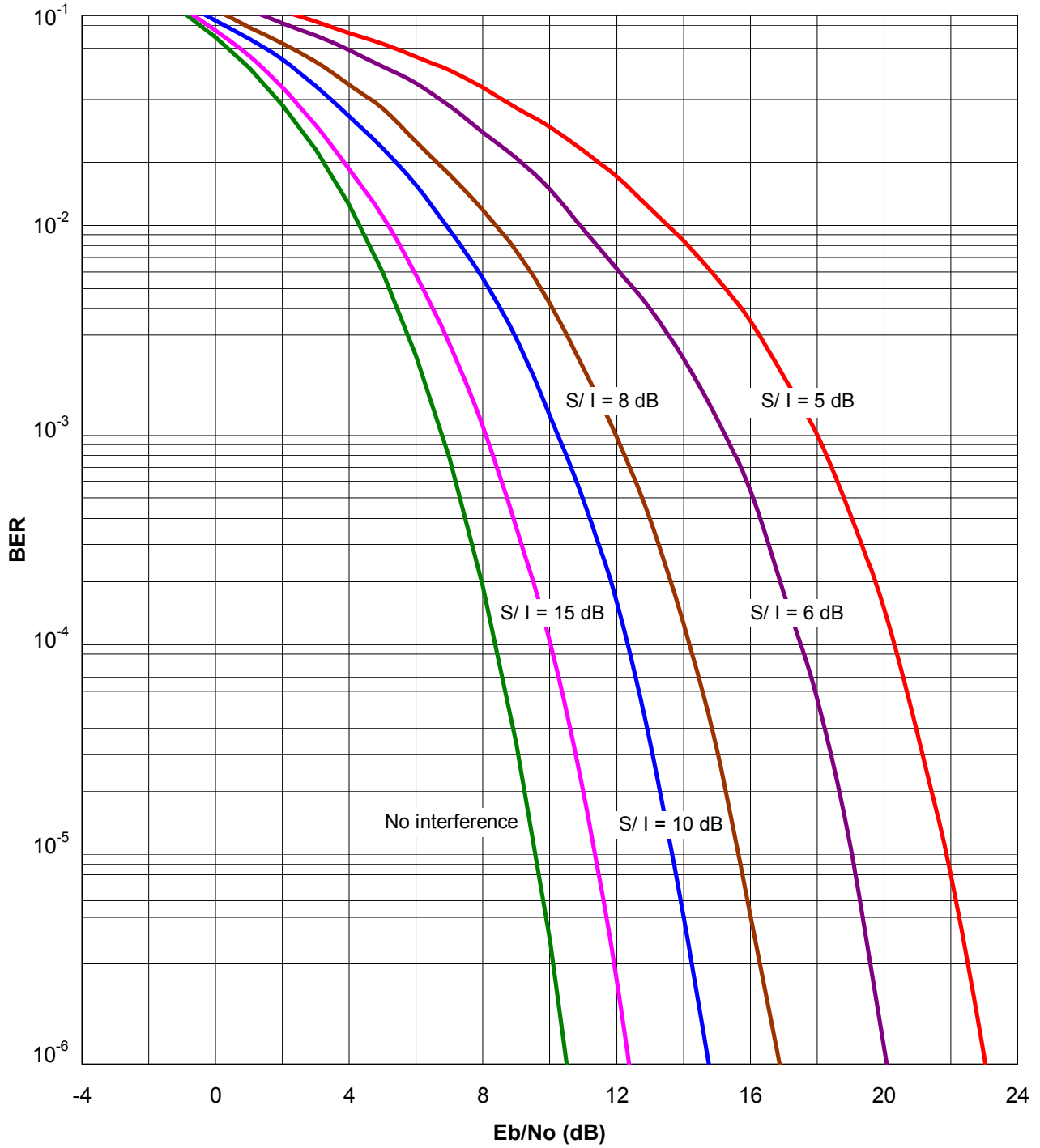

Figure 6.6-2. BER vs. E_b/N_0 Curves for PSK Receiver ($M = 4$) with CW Interference

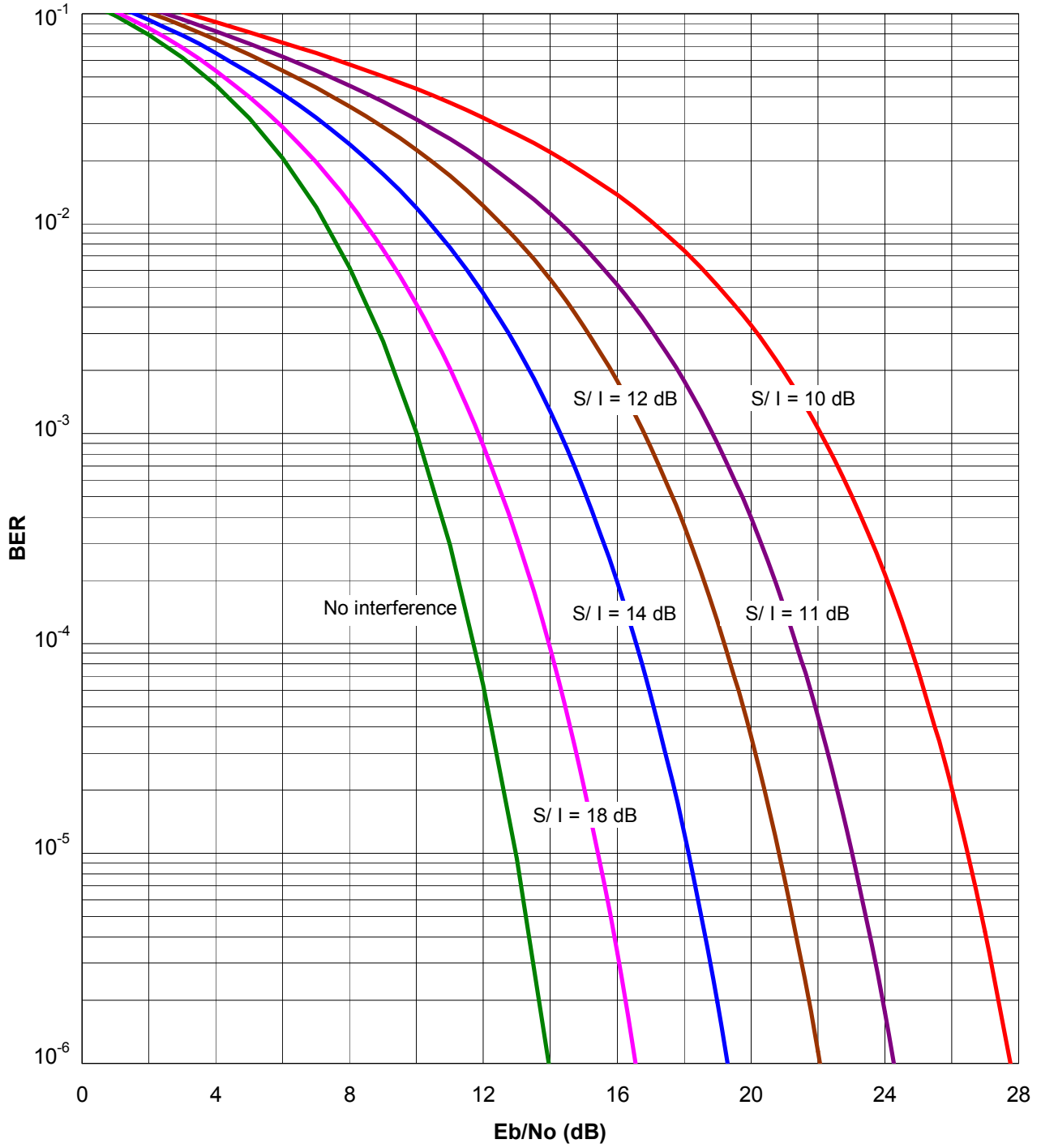

Figure 6.6-3. BER vs. E_b/N_0 Curves for PSK Receiver ($M = 8$) with CW Interference

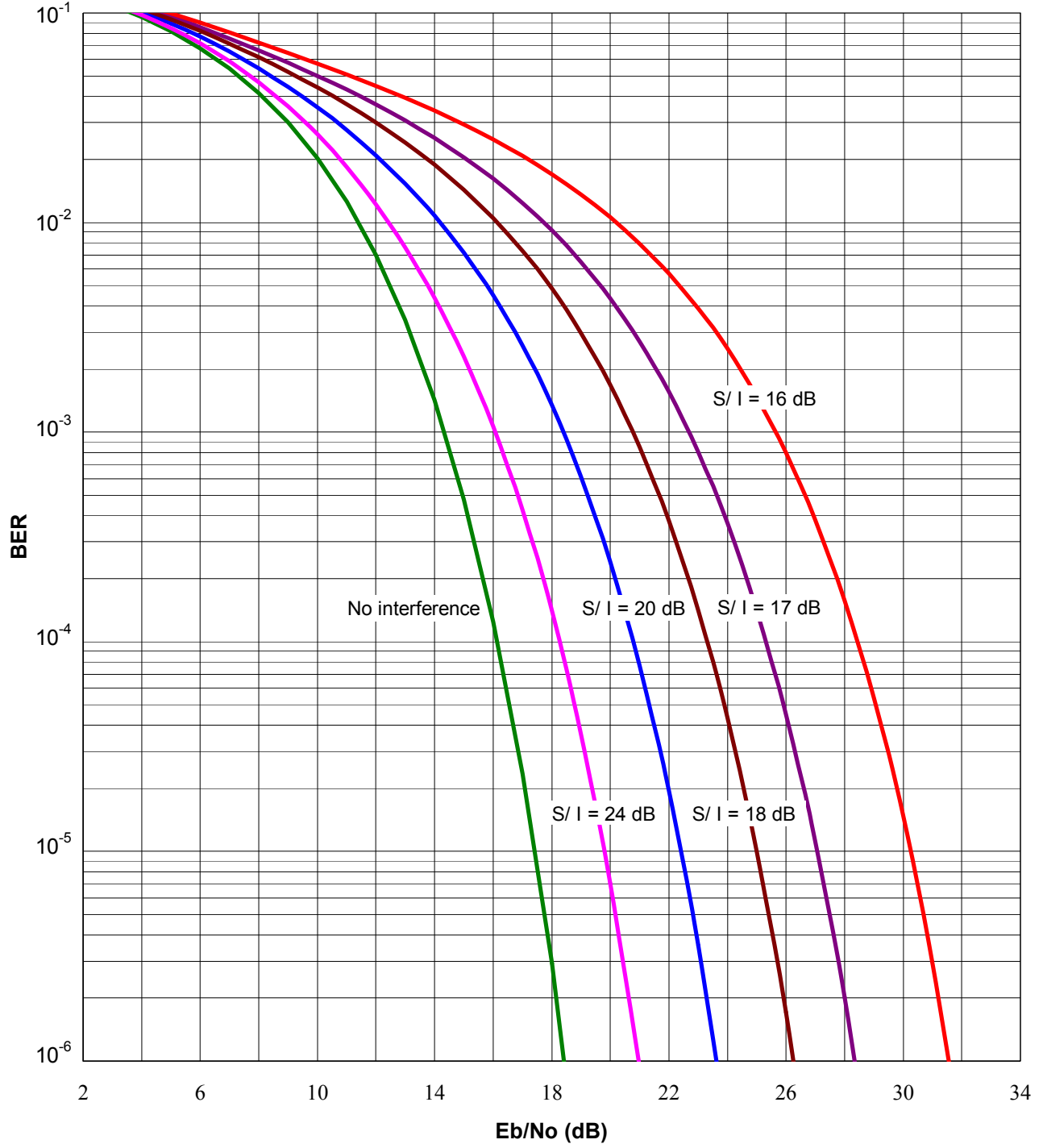

Figure 6.6-4. BER vs. E_b/N_o Curves for PSK Receiver ($M=16$) with CW Interference

6.6.2.2 BER Curves with Pulsed Interference

Before presenting pulsed interference performance degradation results, interference scenarios must be defined. Four scenarios are illustrated in the time domain for the PSK ($M=4$) case. These illustrations give insight into the pulsed interference performance degradation results. Note that the pulsed interferer is shown as having no frequency offset relative to the victim signal.

Figures 6.6-5, 6.6-6, 6.6-7, and 6.6-8 illustrate various pulsed interference scenarios employed in the simulations.

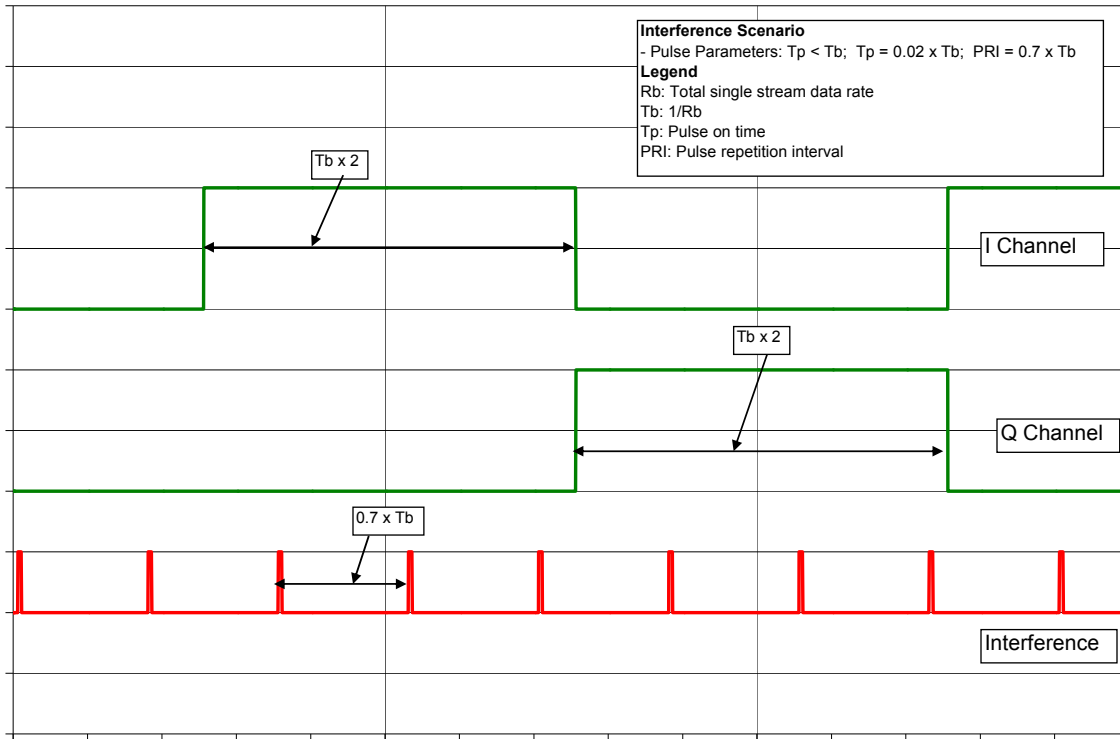

Figure 6.6-5. Pulsed Interference Scenario (Pulse Parameters: $T_p < T_b$; $T_p=0.02T_b$; $PRI=0.7T_b$)

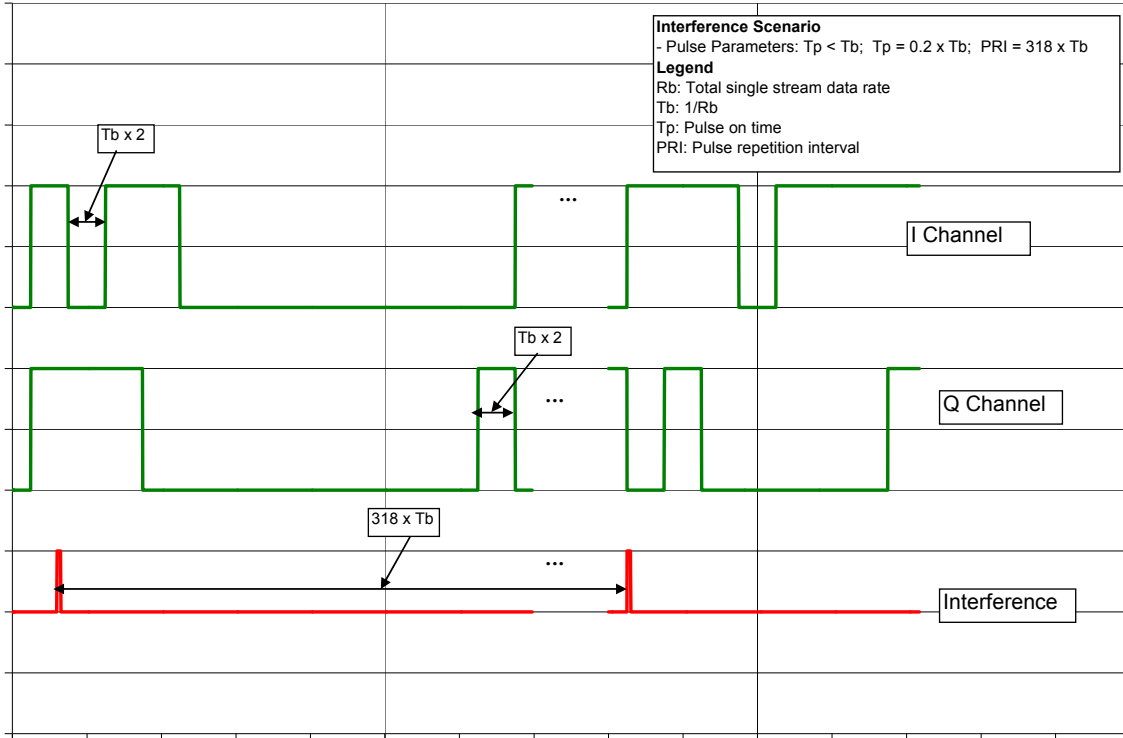

Figure 6.6-6. Pulsed Interference Scenario (Pulse Parameters: $T_p < T_b$; $T_p = 0.2T_b$; $PRI = 318T_b$)

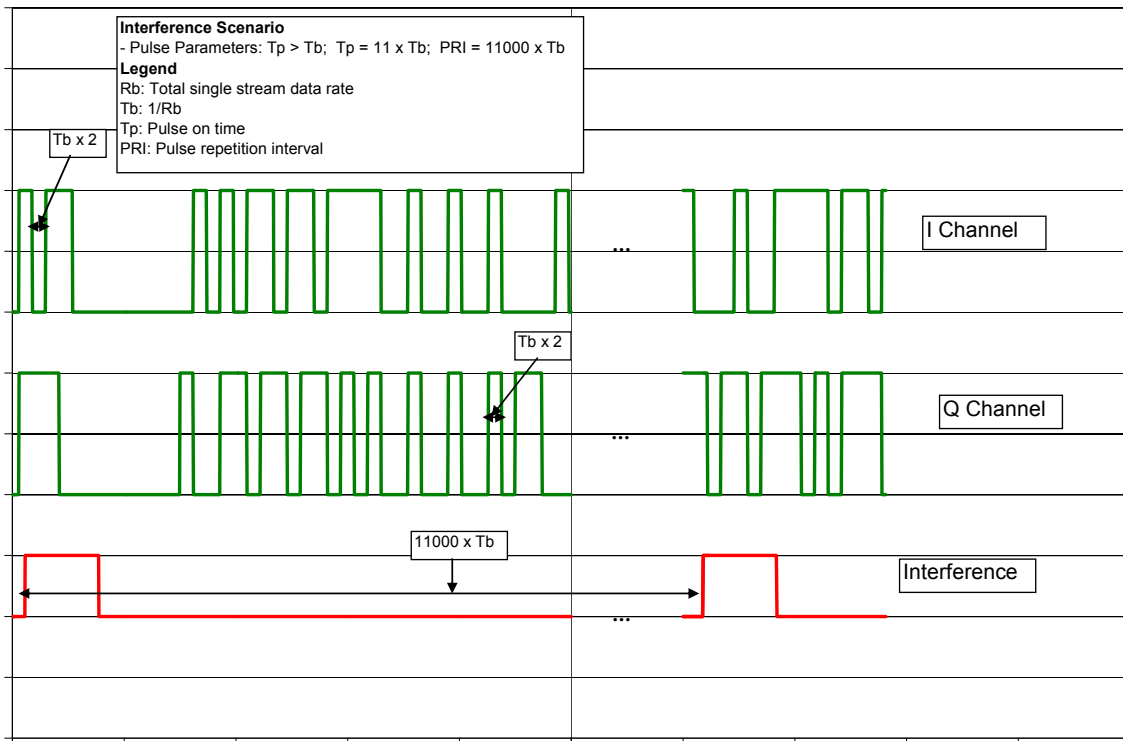

Figure 6.6-7. Pulsed Interference Scenario (Pulse Parameters: $T_p > T_b$; $T_p = 11T_b$; $PRI = 11000T_b$)

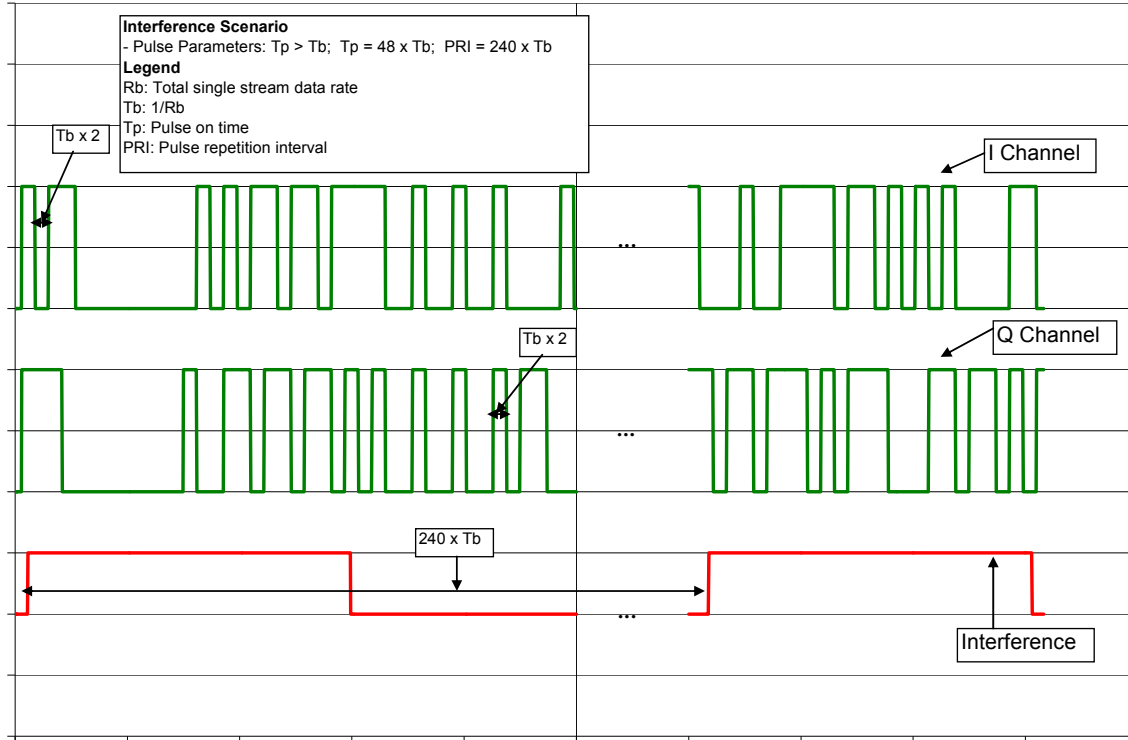

Figure 6.6-8. Pulsed Interference Scenario (Pulse Parameters: $T_p > T_b$; $T_p = 48T_b$; $PRI = 240T_b$)

Figures 6.6-9, 6.6-10, 6.6-11, and 6.6-12 show BER curves for a PSK receiver ($M=4$) with various on-tune pulsed interference scenarios (as annotated on the plots). Figures 6.6-13, 6.6-14, and 6.6-15 show BER curves for a PSK receiver ($M=4$) with various on-tune pulsed broadband AWGN interference scenarios (as annotated on the plots). Figures 6.6-16, 6.6-17, and 6.6-18 show BER curves for a PSK receiver ($M=4$) with various off-tune pulsed interference scenarios (as annotated on the plots).

6.6.2.3 BER Curves with Continuous Interference

Figure 6.6-19 shows BER curves for a PSK receiver ($M=4$) with continuous, same as victim interference. Figure 6.6-20 shows BER curves for a PSK receiver ($M=4$) with continuous Orthogonal Frequency Division Multiplexing (OFDM) interference.

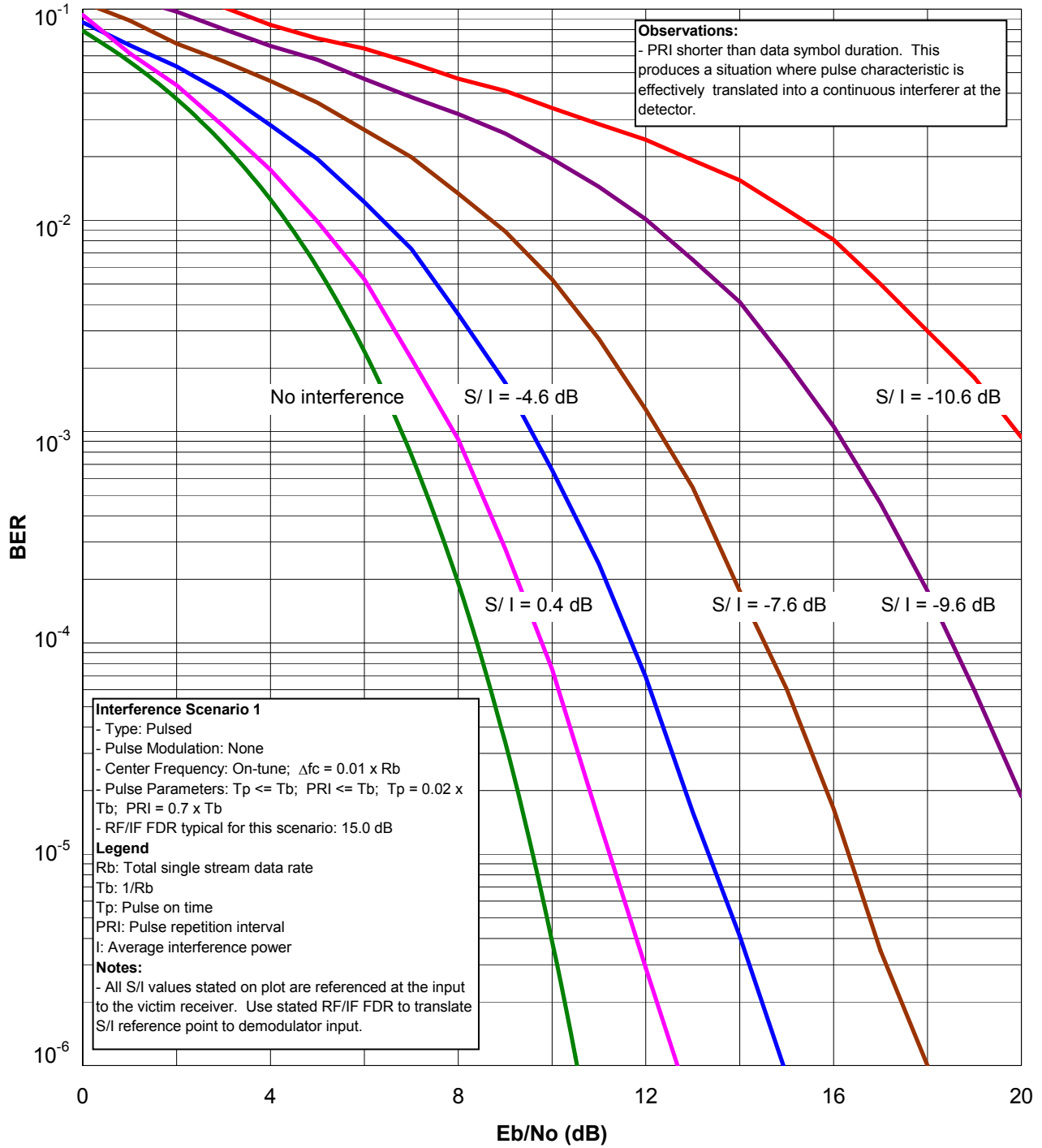

Figure 6.6-9. BER vs. E_b/N_0 Curves for PSK Receiver ($M = 4$) with On-Tune Pulsed Interference Scenario 1

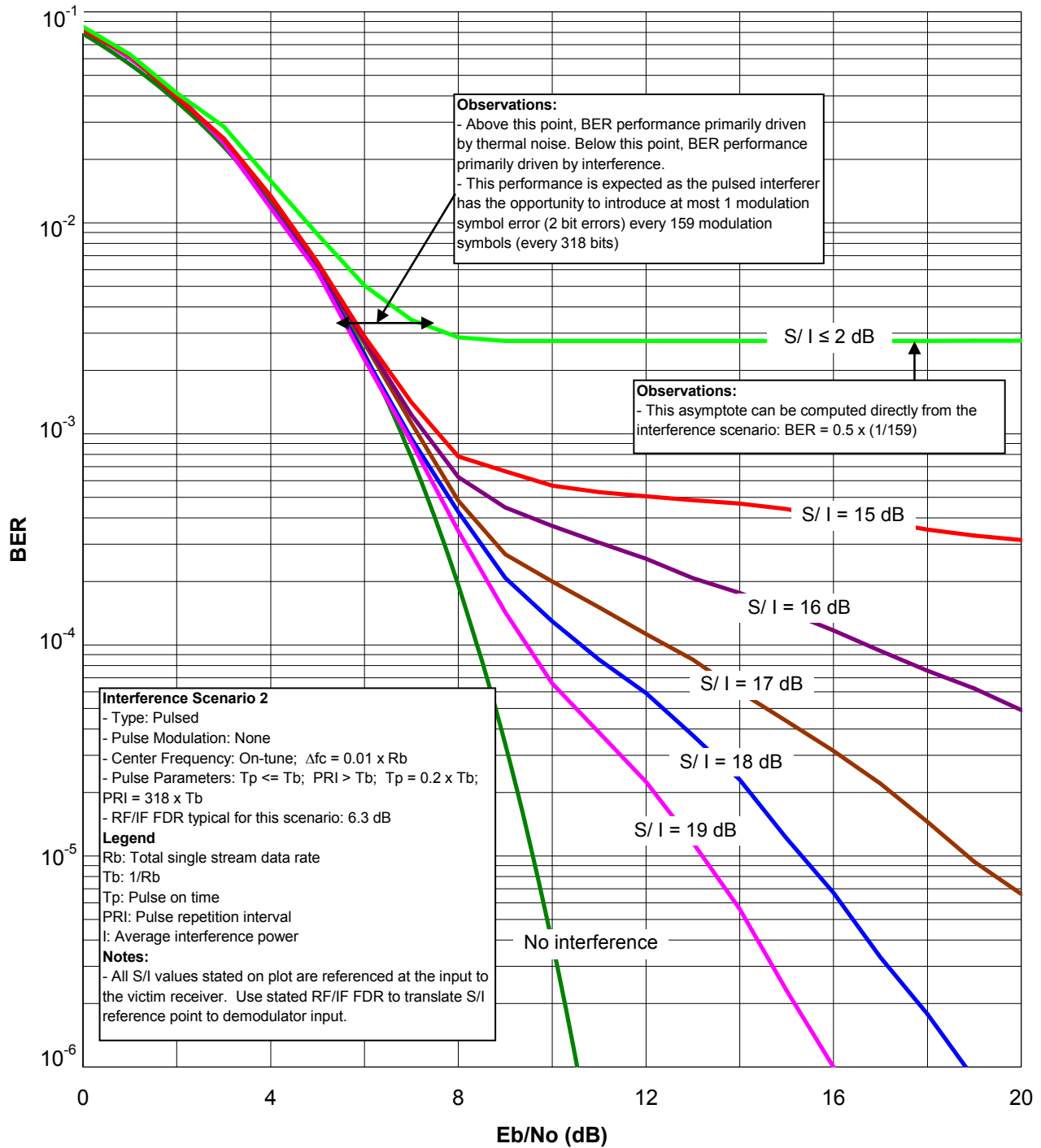

Figure 6.6-10. BER vs. E_b/N_o Curves for PSK Receiver ($M = 4$) with On-Tune Pulsed Interference Scenario 2

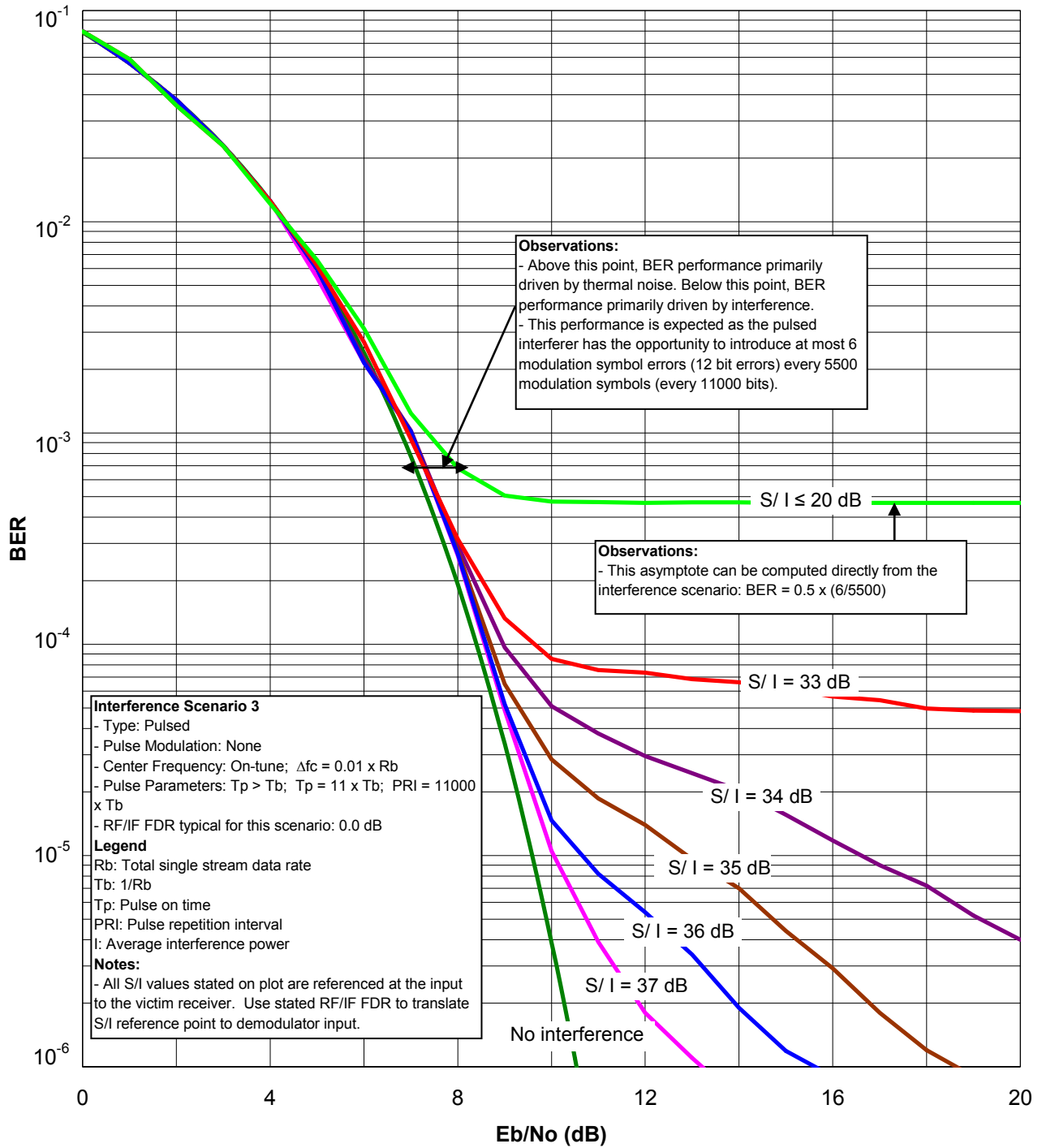

Figure 6.6-11. BER vs. E_b/N_o Curves for PSK Receiver ($M = 4$) with On-Tune Pulsed Interference Scenario 3

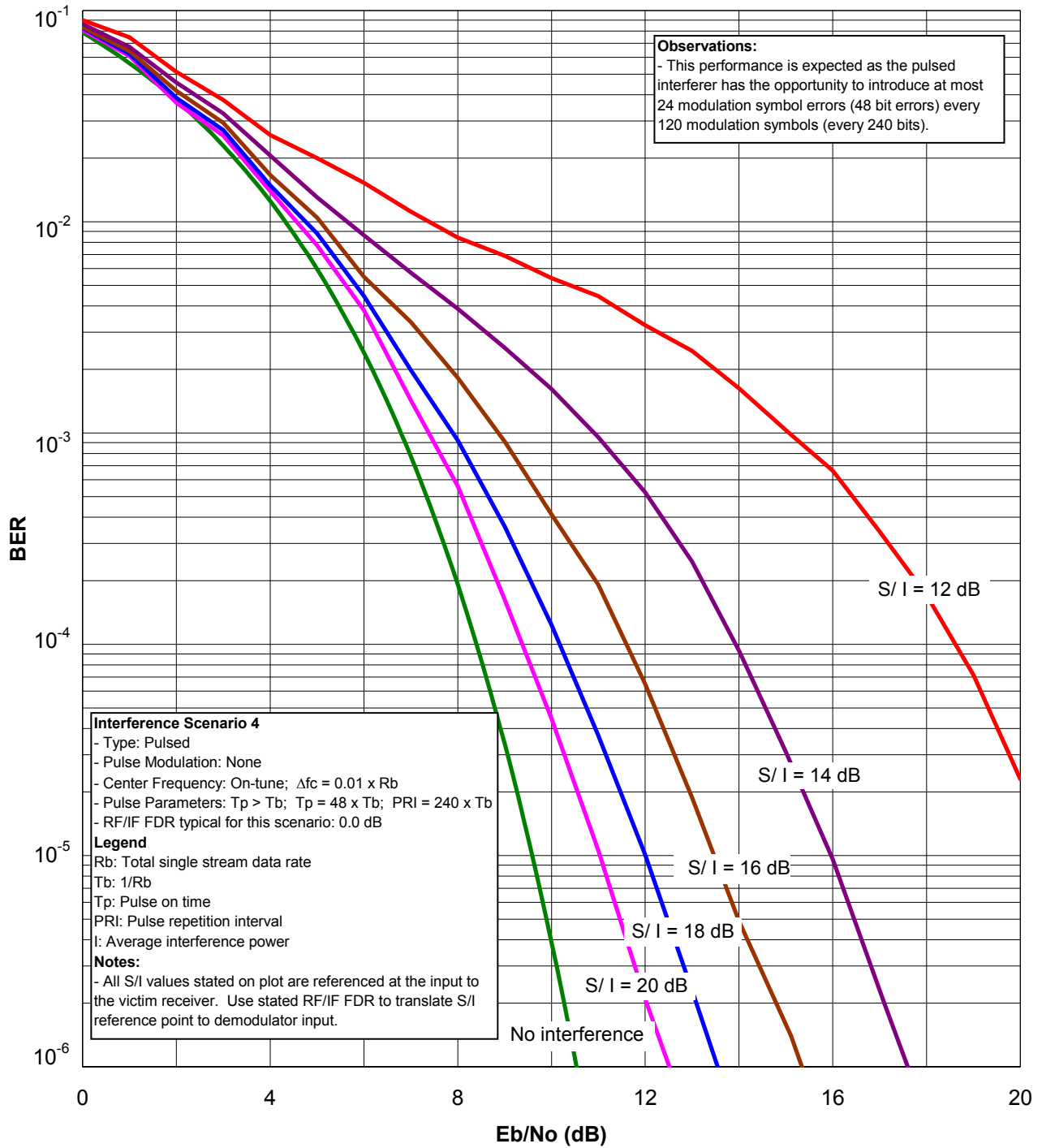

Figure 6.6-12. BER vs. E_b/N_o Curves for PSK Receiver ($M = 4$) with On-Tune Pulsed Interference Scenario 4

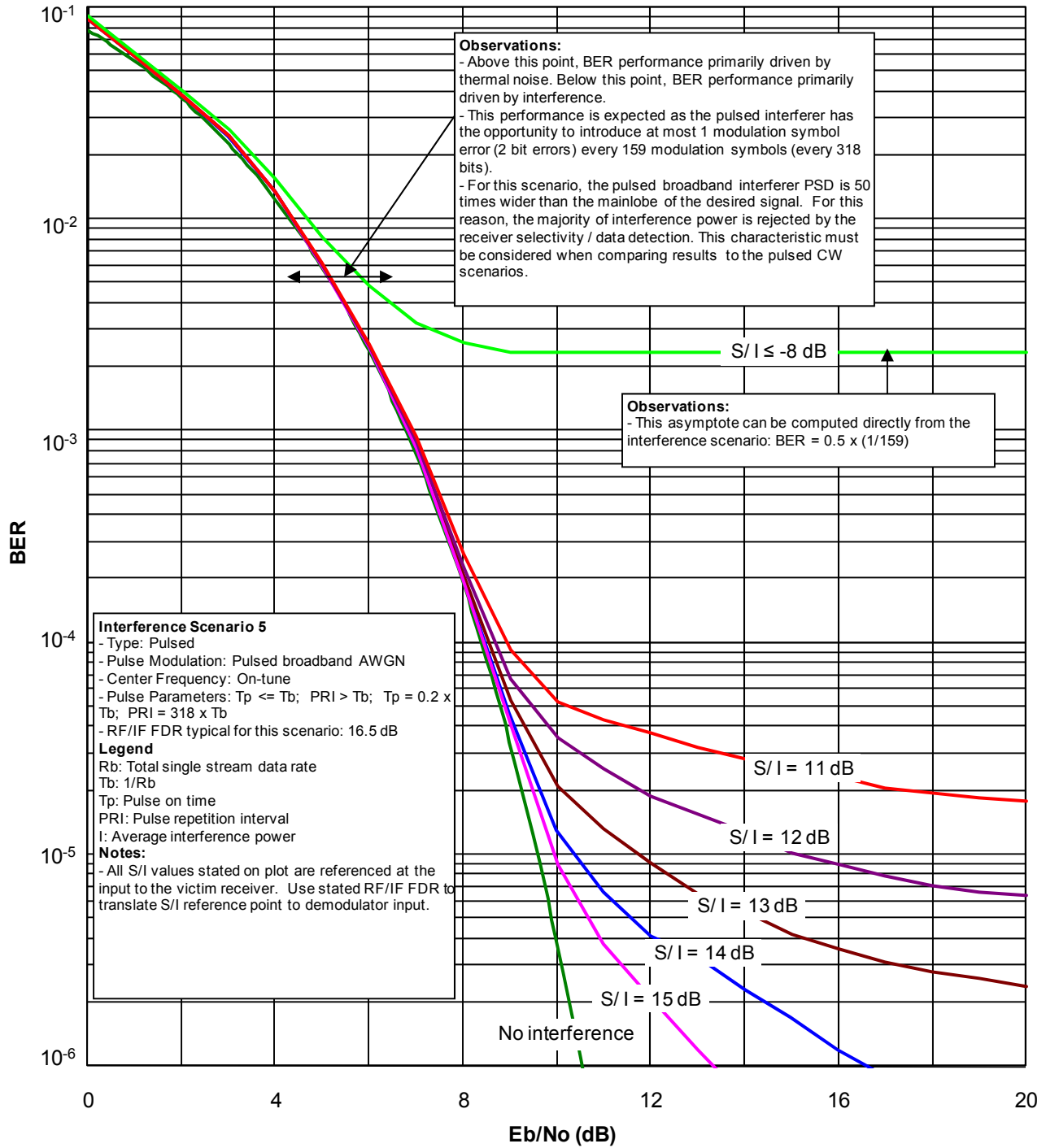

Figure 6.6-13. BER vs. E_b/N_o Curves for PSK Receiver ($M = 4$) with On-Tune Pulsed Broadband AWGN Interference Scenario 5

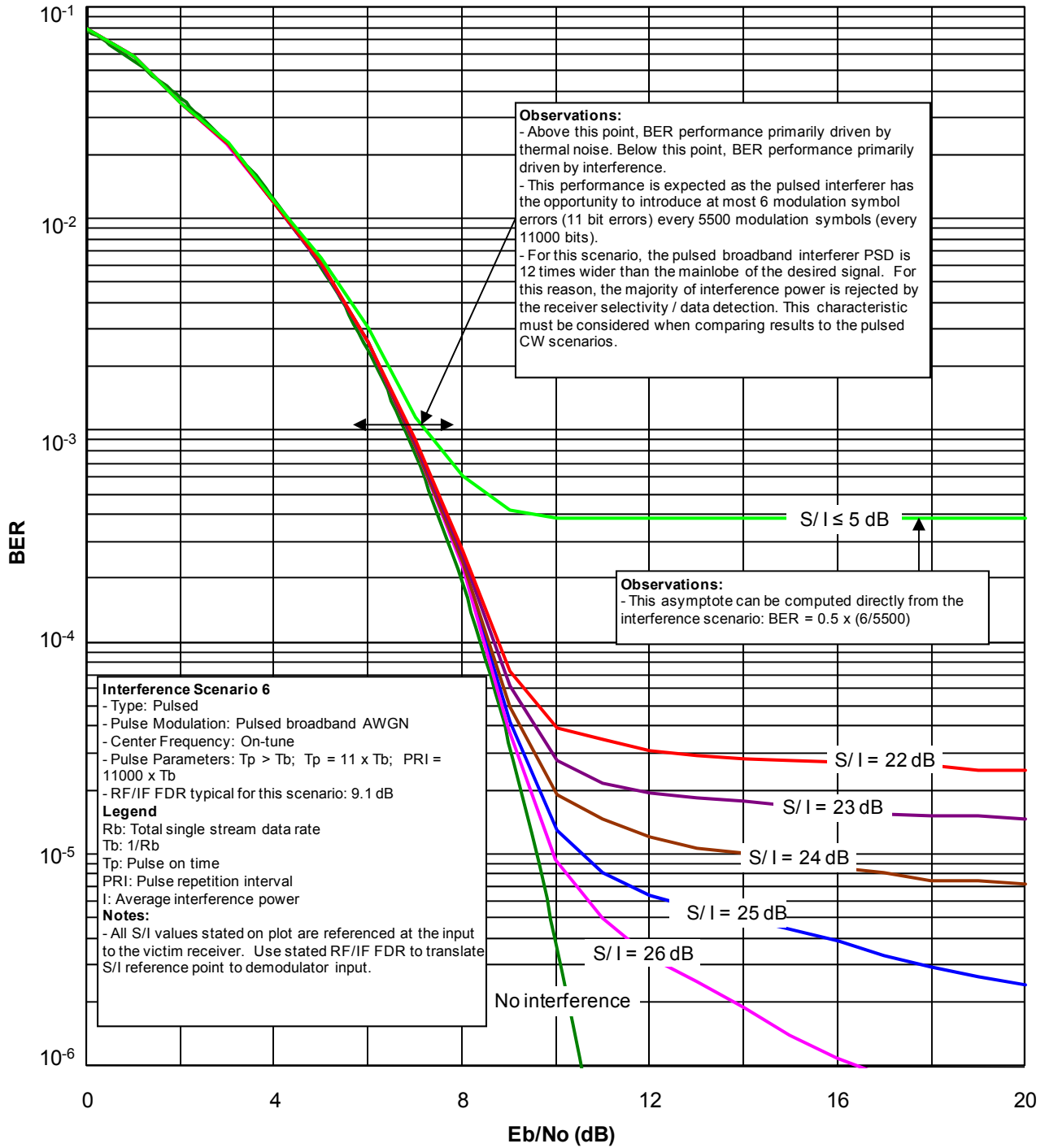

Figure 6.6-14. BER vs. E_b/N_o Curves for PSK Receiver ($M = 4$) with On-Tune Pulsed Broadband AWGN Interference Scenario 6

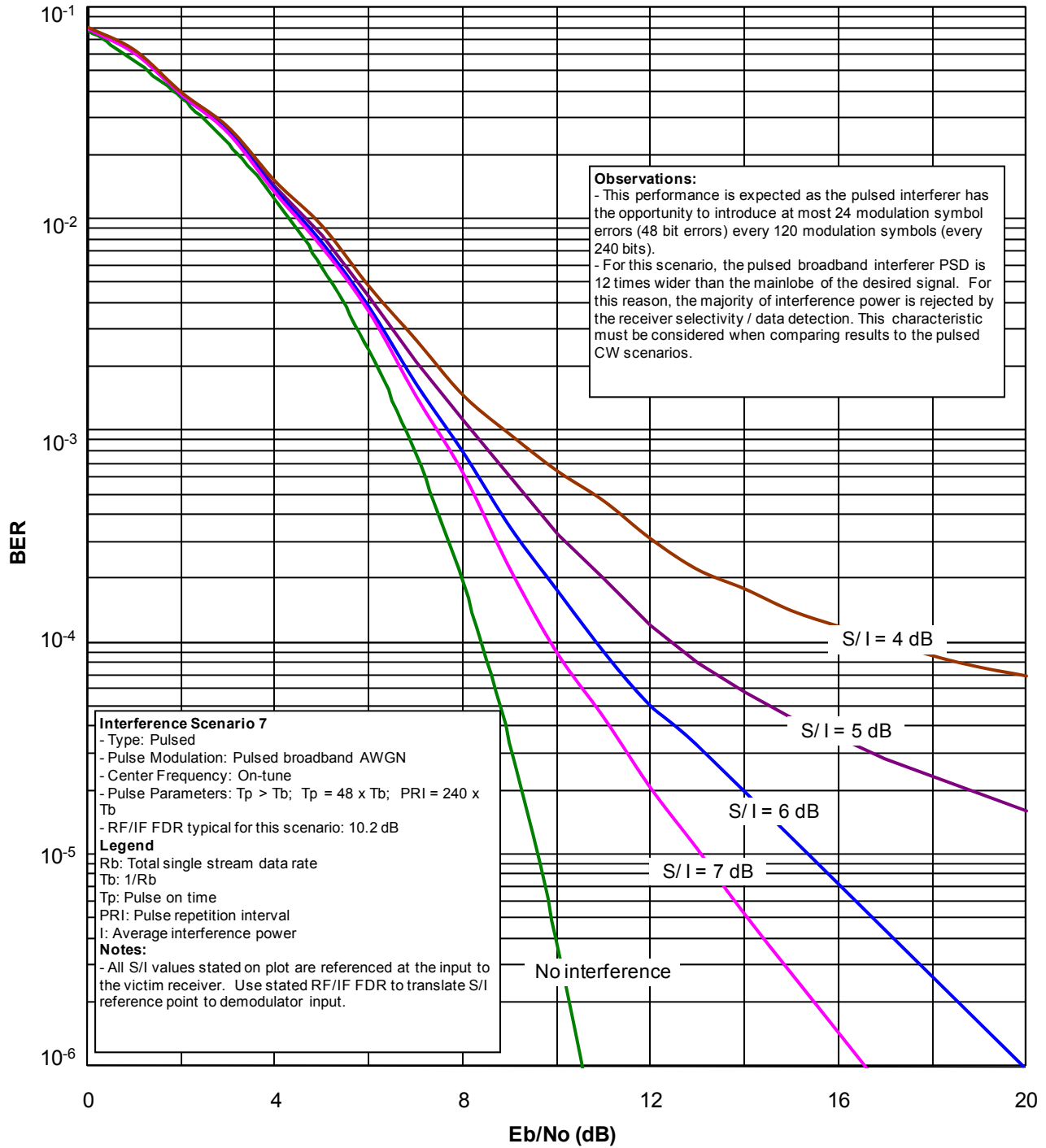

Figure 6.6-15. BER vs. E_b/N_0 Curves for PSK Receiver ($M = 4$) with On-Tune Pulsed Broadband AWGN Interference Scenario 7

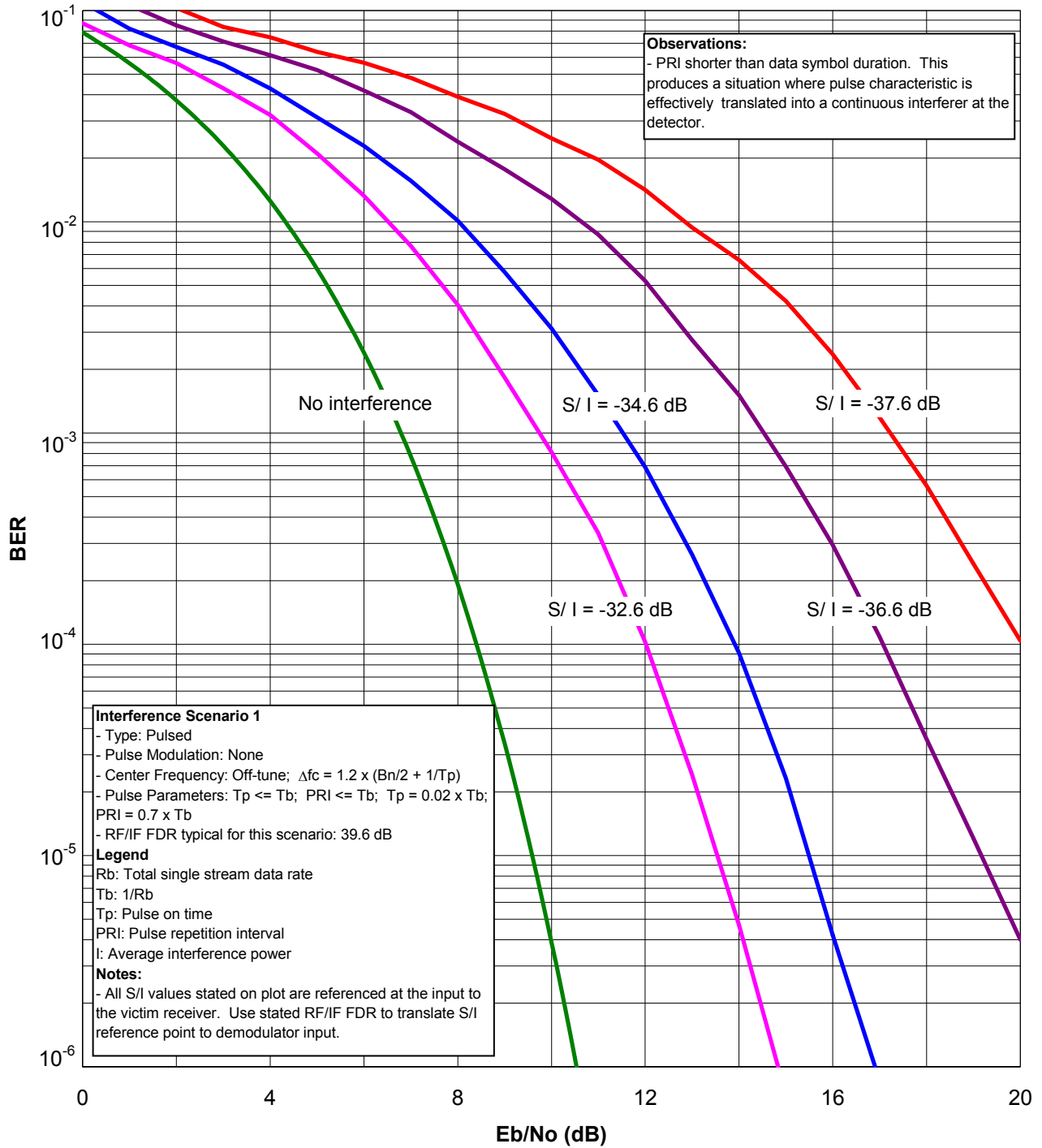

Figure 6.6-16. BER vs. E_b/N_0 Curves for PSK Receiver ($M = 4$) with Off-Tune Pulsed Interference Scenario 1

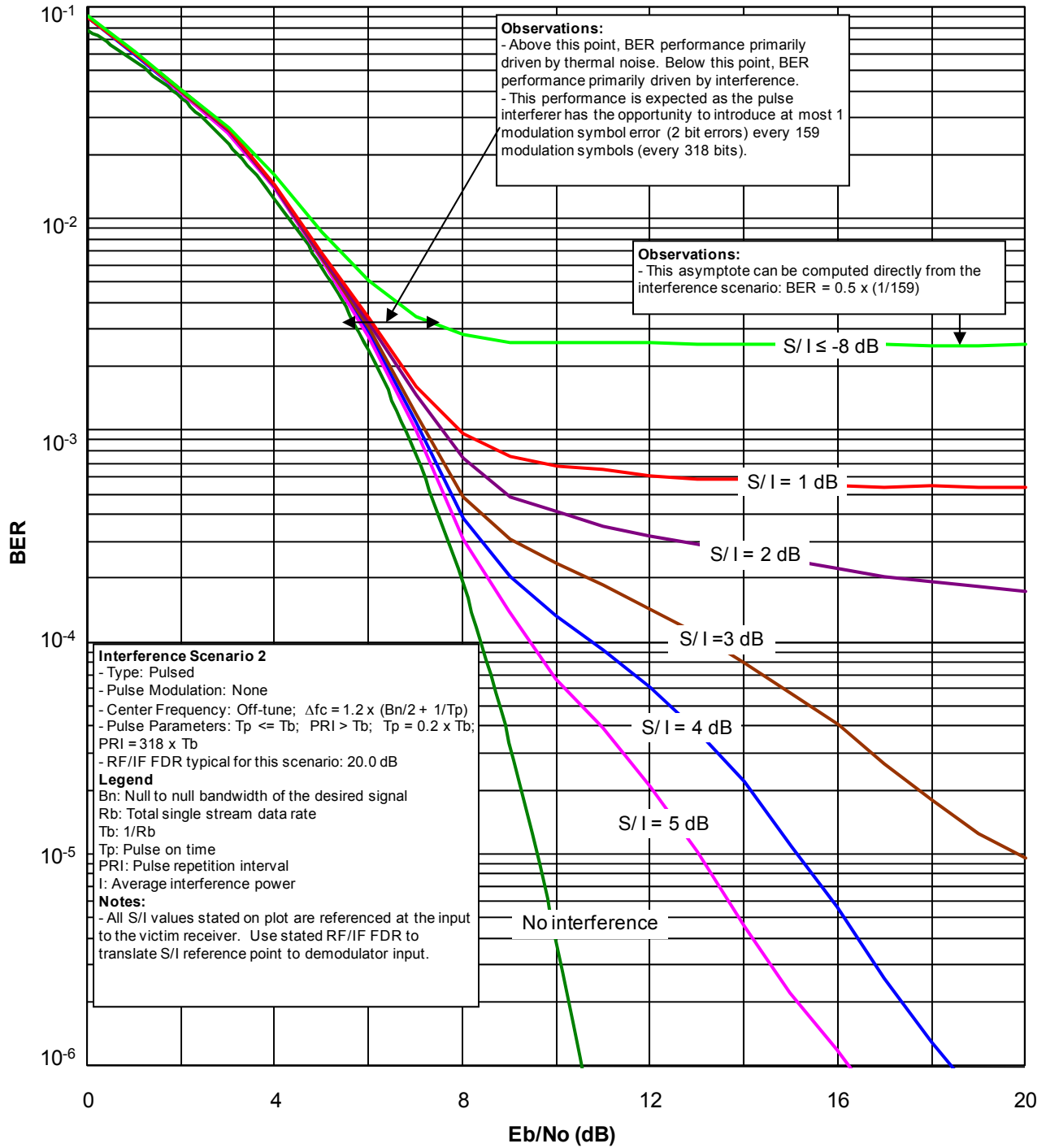

Figure 6.6-17. BER vs. E_b/N_o Curves for PSK Receiver ($M = 4$) with Off-Tune Pulsed Interference Scenario 2

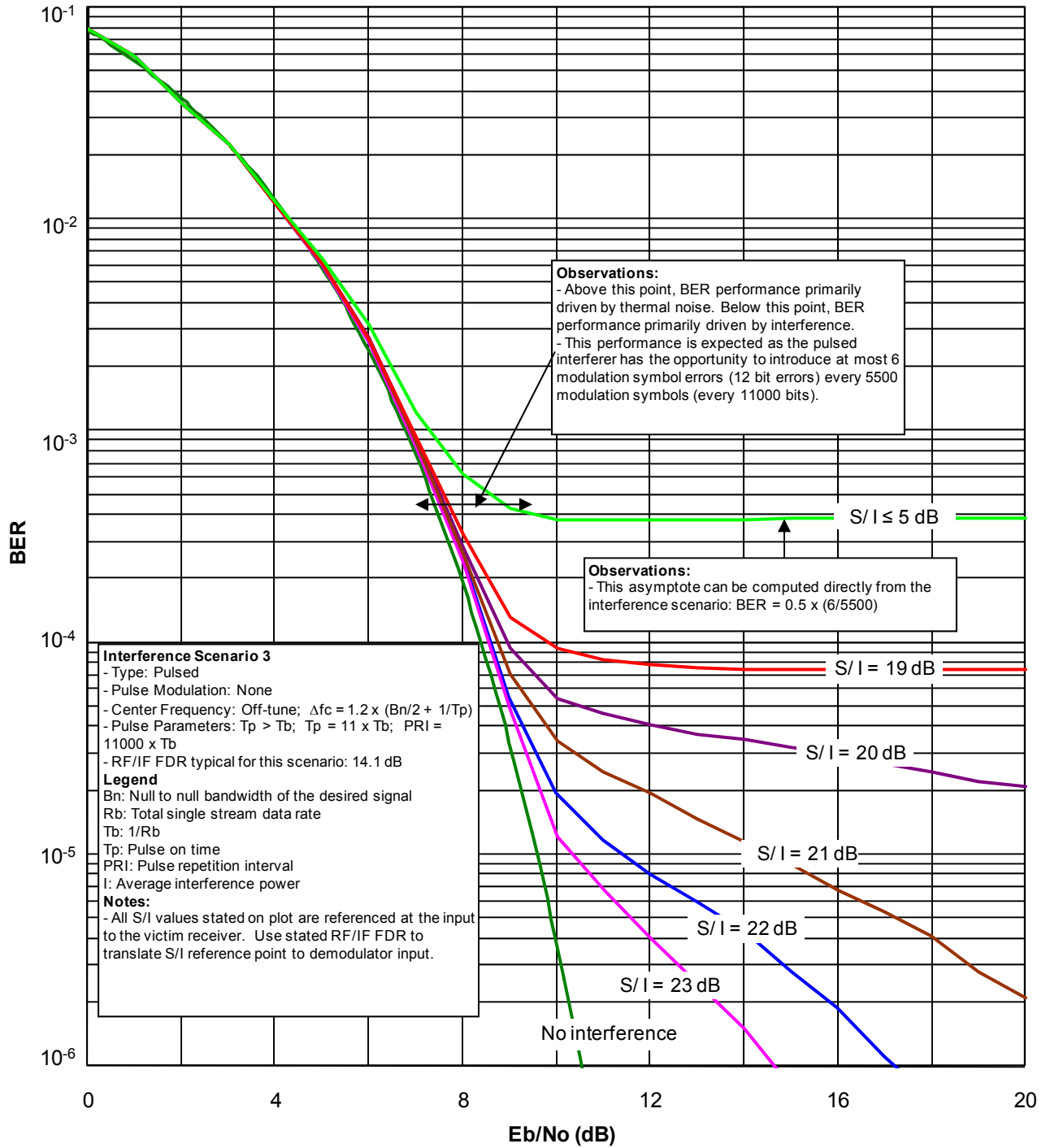

Figure 6.6-18. BER vs. E_b/N_o Curves for PSK Receiver ($M = 4$) with Off-Tune Pulsed Interference Scenario 3

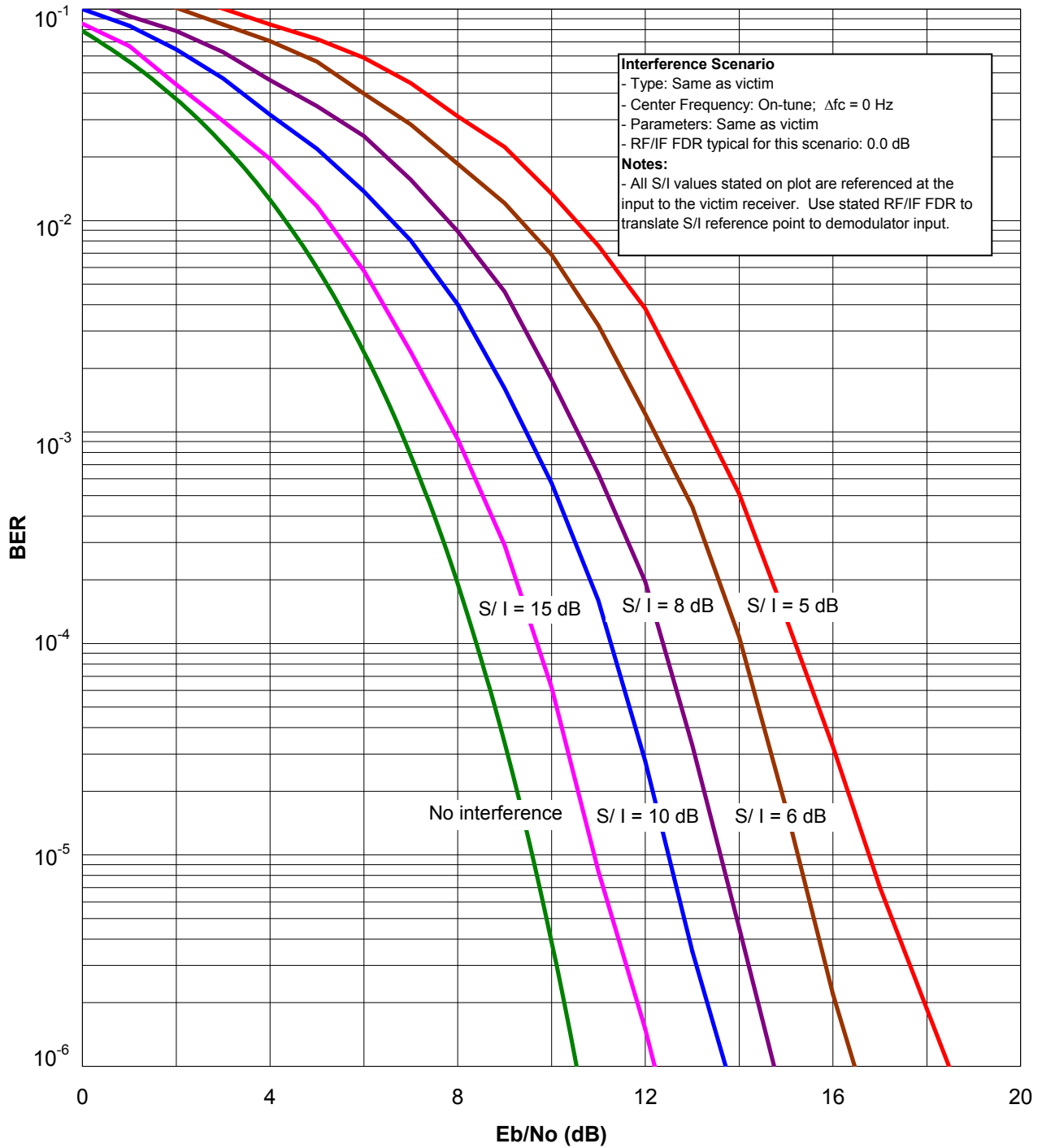

Figure 6.6-19. BER vs. E_b/N_0 Curves for PSK Receiver ($M = 4$) with Same as Victim Interference

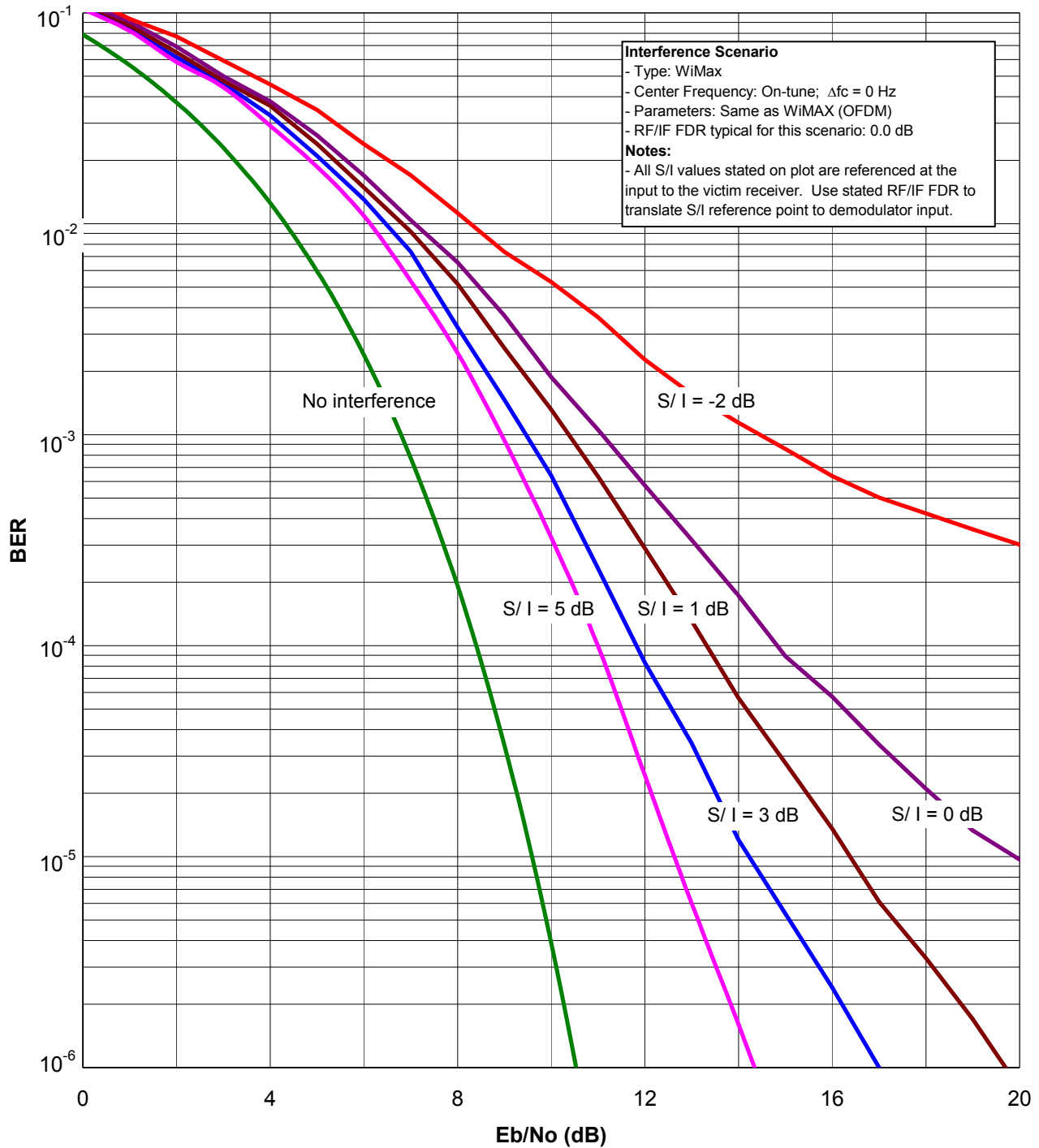

Figure 6.6-20. BER vs. E_b/N_0 Curves for PSK Receiver ($M = 4$) with WiMax (OFDM) Interference

6.7 DIFFERENTIAL PHASE-SHIFT KEYING

DPSK is a noncoherent modulation scheme. In coherent reception, the receiver regenerates the carrier from the received signal and then uses the regenerated carrier as a reference for determining the phase of the modulating signal. In DPSK, the receiver does not regenerate the carrier. The demodulator compares the phase of the current bit waveform to the phase of the previous bit

waveform rather than to the carrier. Although DPSK permits a simpler receiver implementation, the error performance is not as good as the coherent case. Coherent PSK is presented in Section 6.6.

6.7.1 Description

The waveforms for DPSK are the same as for PSK as shown in Equations 6-17, 6-20, and 6-23. However, the phase term in the equation has a different interpretation. In coherent PSK, a waveform has the phase $i2\pi/M$ when the corresponding symbol value is i . In DPSK, two succeeding waveforms have the phase difference $i2\pi/M$ when the corresponding symbol value is i .

For noise and noise-like interference, the BER for binary DPSK is given by:

$$BER = \frac{1}{2} \exp\left(-\frac{E_b}{N_o}\right) \quad (6-26)$$

For DPSK with $M > 2$, the SER for noise and noise-like interference is given by:

$$SER = \text{erfc}\left[\sqrt{k \frac{E_b}{N_o}} \sin\left(\frac{\pi}{\sqrt{2M}}\right)\right]$$

Thus, it follows from Equation 6-12 that

$$BER = \frac{1}{k} \text{erfc}\left[\sqrt{k \frac{E_b}{N_o}} \sin\left(\frac{\pi}{\sqrt{2M}}\right)\right] \quad (6-27)$$

6.7.2 BER Curves

Figures 6.7-1, 6.7-2, and 6.7-3 show BER curves for a DPSK receiver with $M = 2$, $M = 4$, and $M = 8$, respectively. In these graphs, the term “interference” and the variable I refer to CW interference. Any noise-like interference power is simply assumed to be added (in mW) to the noise power. For example, suppose there are two interfering signals: a CW signal and a noise-like signal. The S/I parameter is the ratio of the desired signal power to the CW interfering signal power, and the x-axis variable E_b/N_o is calculated with Equation 6-4, where N is the total noise-like power (including the receiver noise and the noise-like interfering signal).

The curves were generated by simulation. Each figure displays six curves. Each curve is a plot of BER vs. E_b/N_o . The curve labeled “No interference” applies to the case in which there is no CW interference. The other five curves are for cases with CW interference. Each of those five curves is labeled with the S/I for that curve. As expected, each curve shows that the BER decreases as the E_b/N_o increases. As also expected, for a given E_b/N_o the BER decreases as the S/I increases.

Figures 6.7-4, 6.7-5, 6.7-6, and 6.7-7 show BER curves for a 4-ary DPSK receiver with various on-tune pulsed interference scenarios (as annotated on the plots).

Figures 6.7-8, 6.7-9, and 6.7-10 show BER curves for a 4-ary DPSK receiver with various off-tune pulsed interference scenarios (as annotated on the plots).

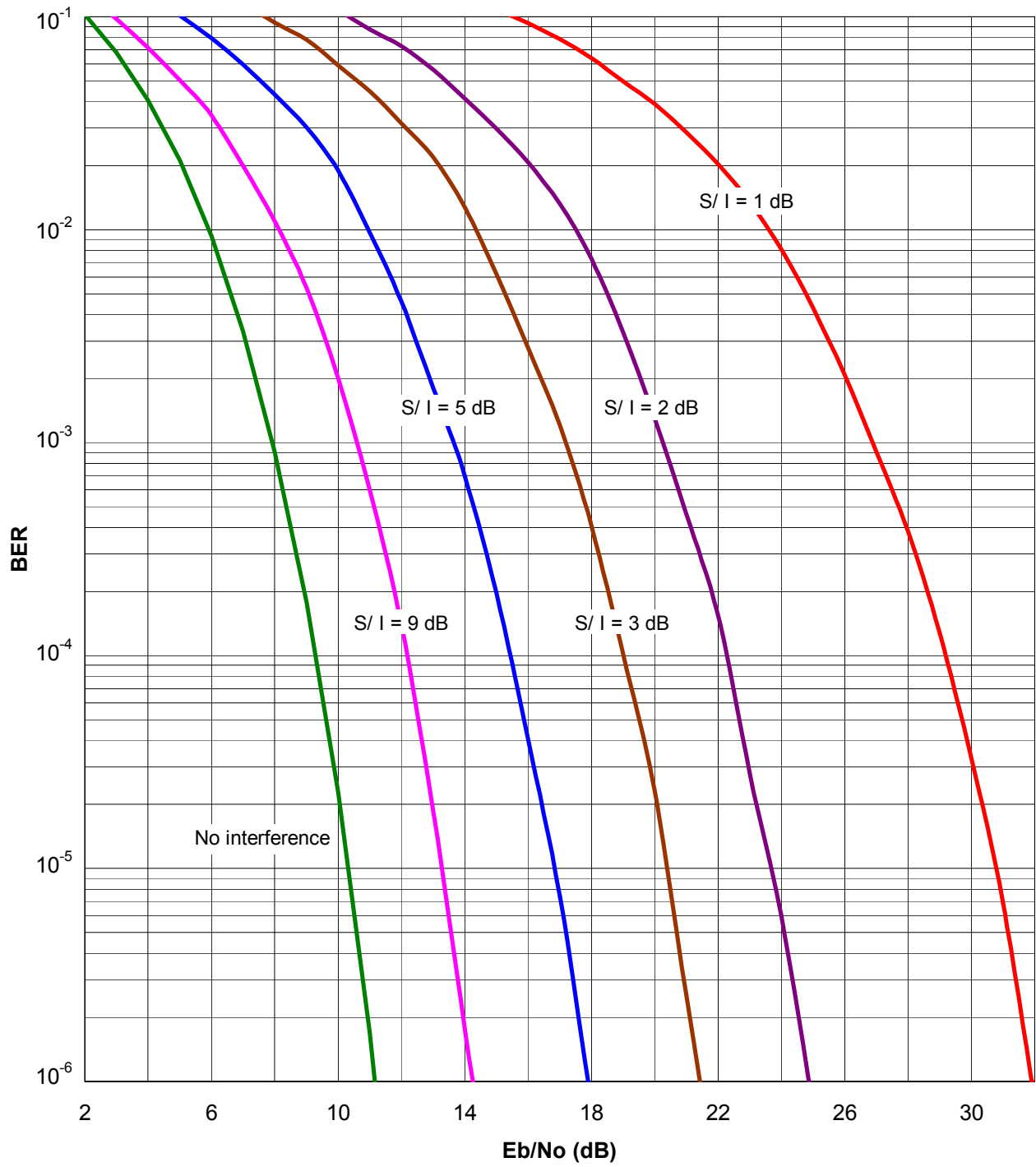

Figure 6.7-1. BER vs. E_b/N_o Curves for DPSK Receiver ($M = 2$) with CW Interference

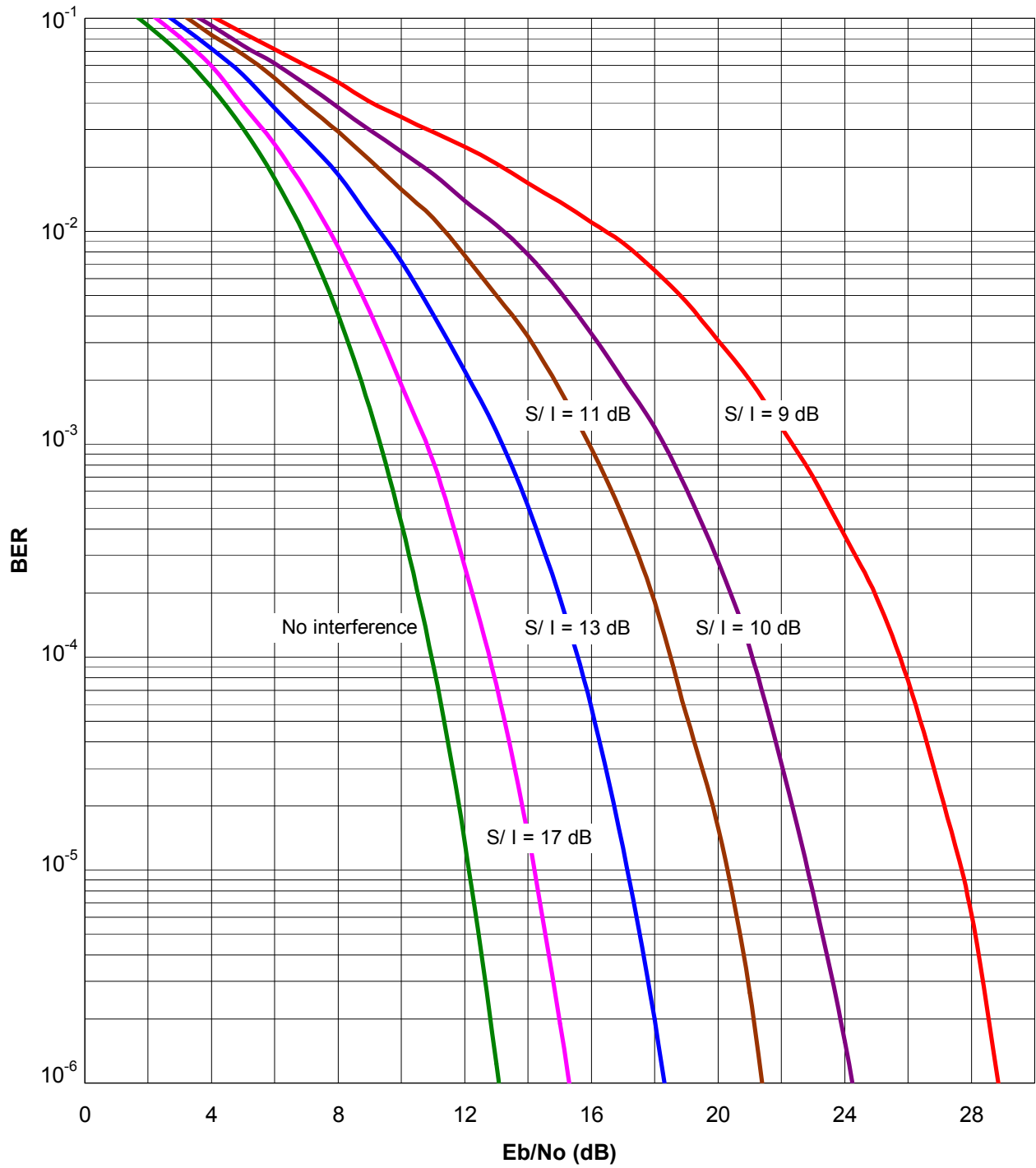

Figure 6.7-2. BER vs. E_b/N_o Curves for DPSK Receiver ($M = 4$) with CW Interference

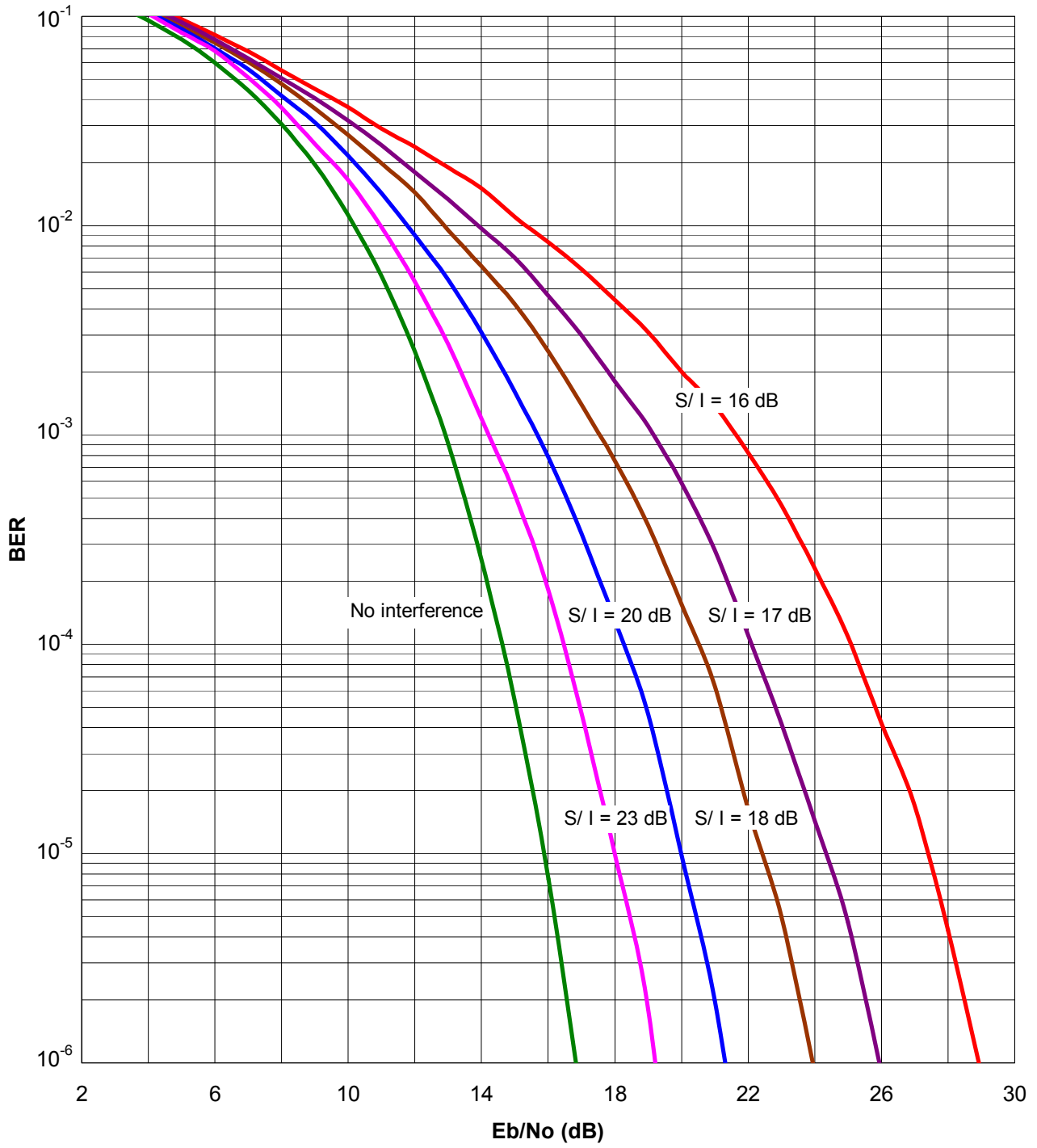

Figure 6.7-3. BER vs. E_b/N_o Curves for DPSK Receiver ($M = 8$) with CW Interference

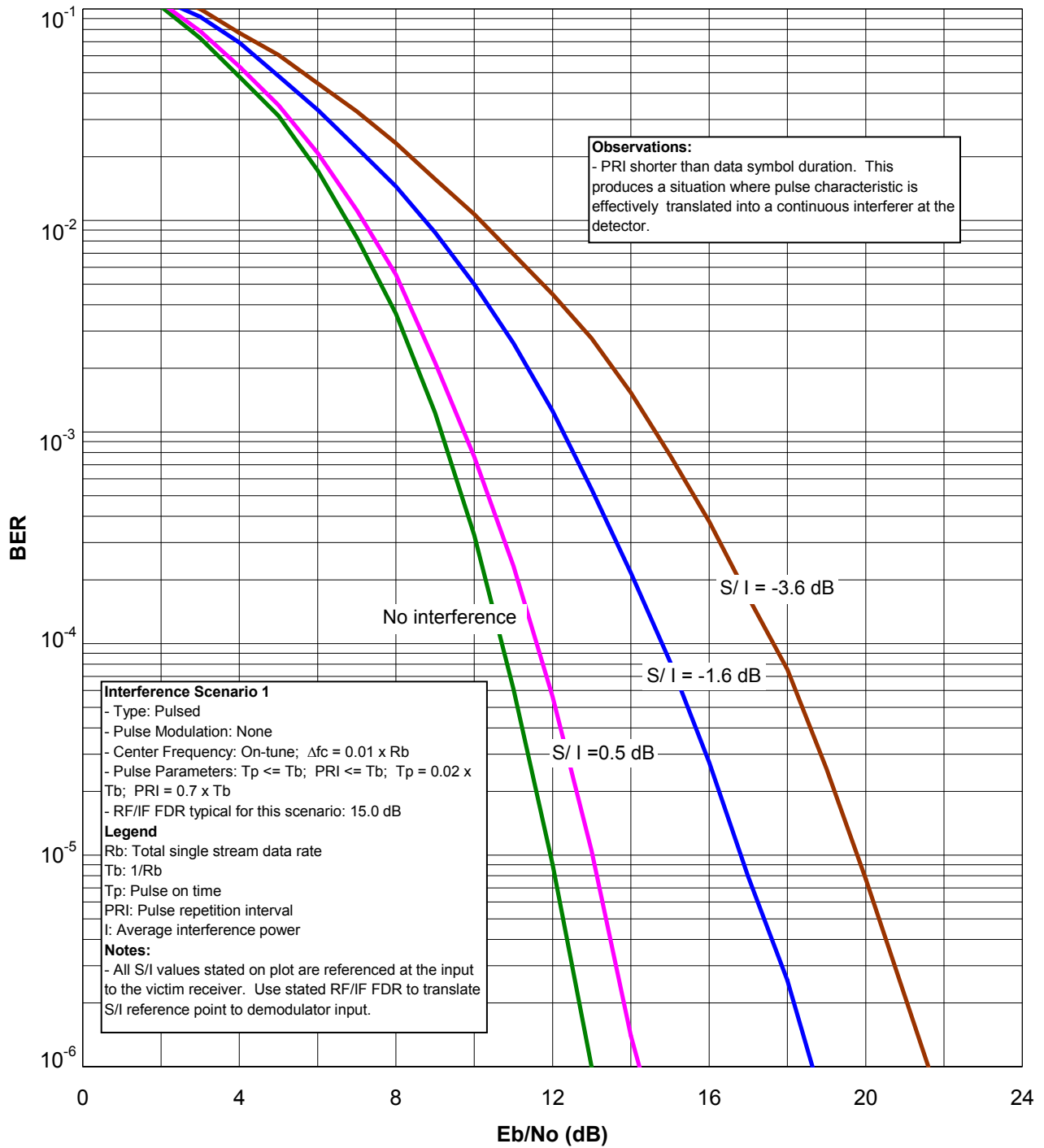

Figure 6.7-4. BER vs. E_b/N_o Curves for DPSK Receiver ($M = 4$) with On-Tune Pulsed Interference Scenario 1

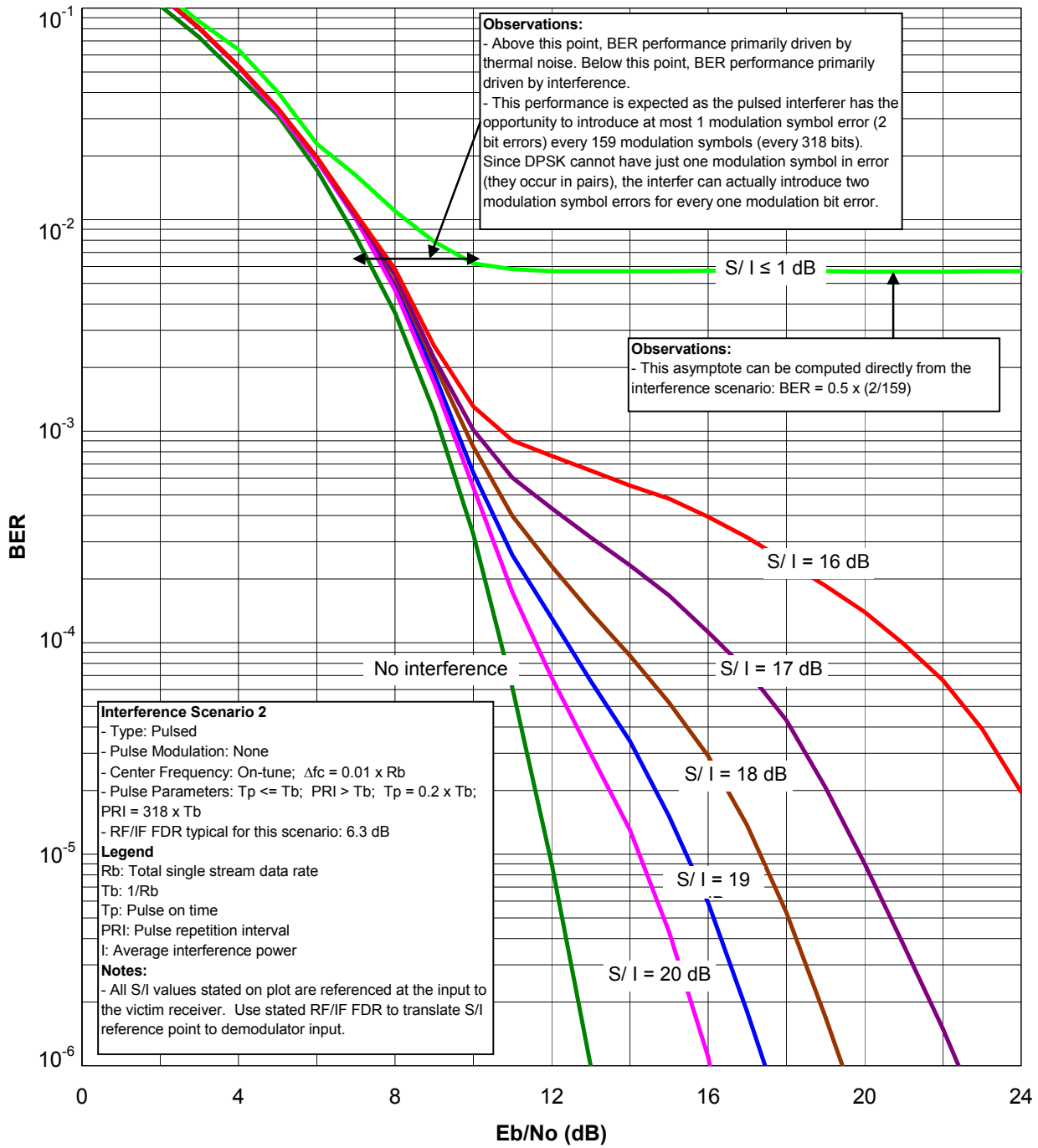

Figure 6.7-5. BER vs. E_b/N_o Curves for DPSK Receiver ($M = 4$) with On-Tune Pulsed Interference Scenario 2

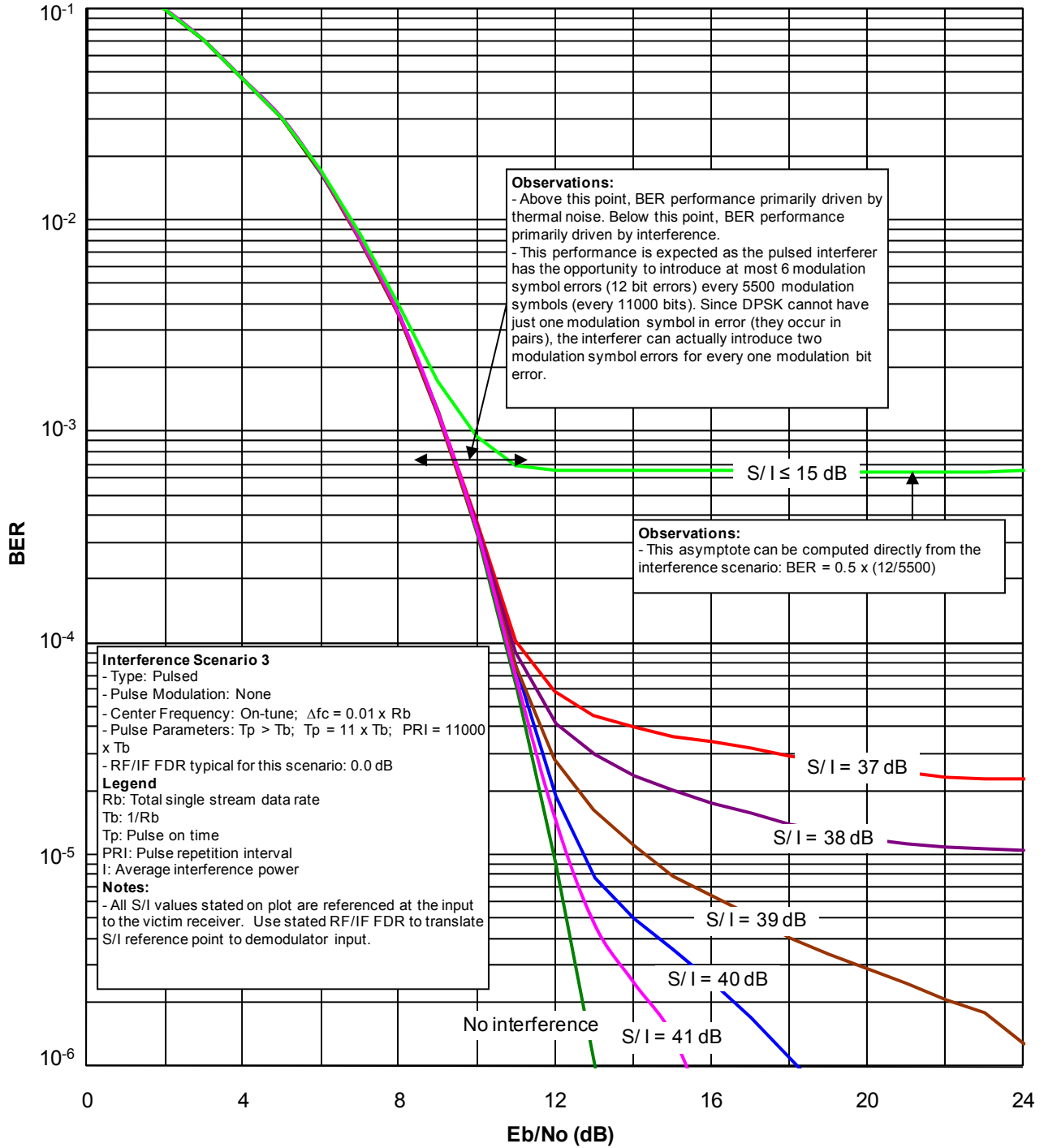

Figure 6.7-6. BER vs. E_b/N_o Curves for DPSK Receiver ($M = 4$) with On-Tune Pulsed Interference Scenario 3

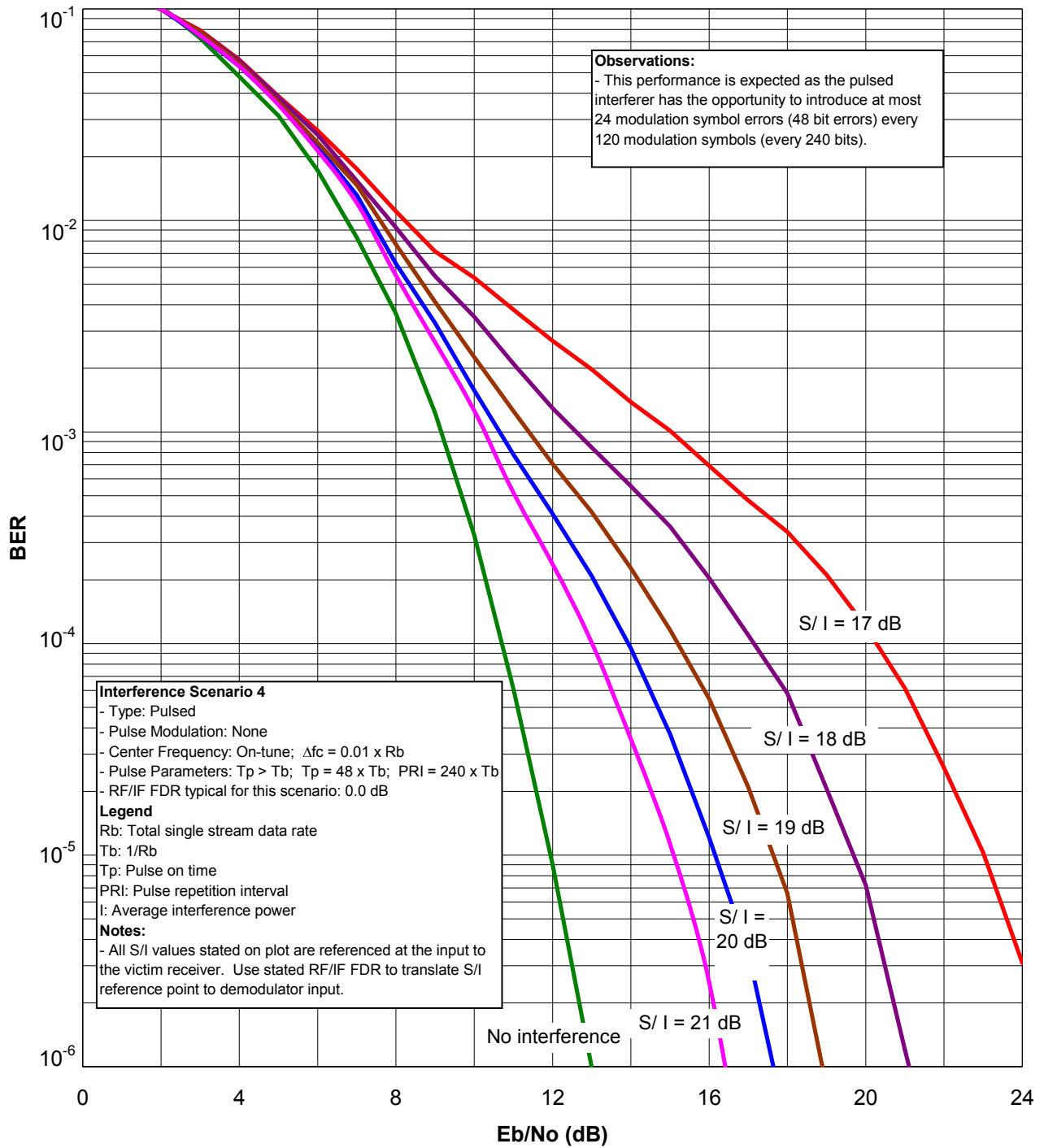

Figure 6.7-7. BER vs. E_b/N_o Curves for DPSK Receiver ($M = 4$) with On-Tune Pulsed Interference Scenario 4

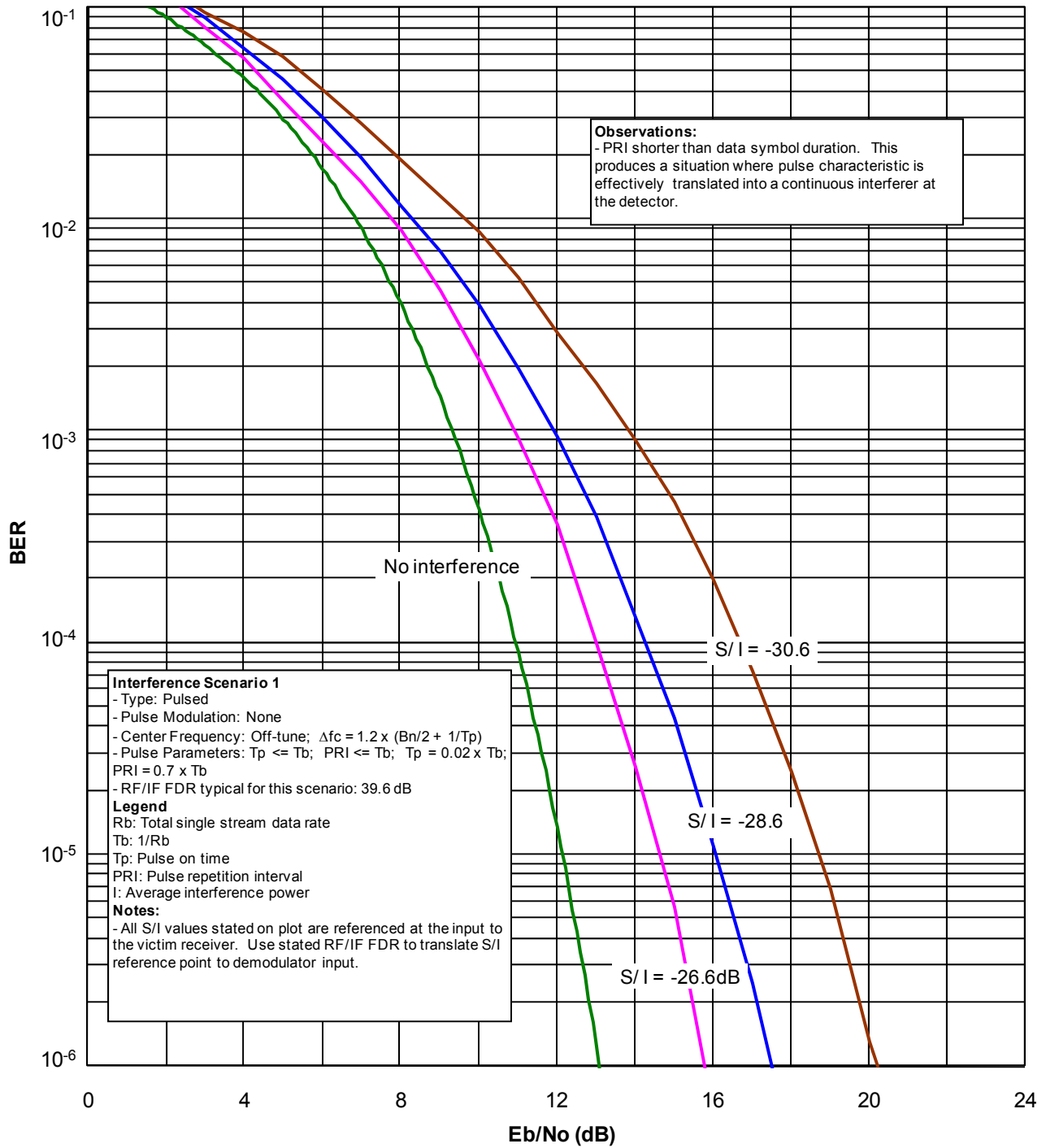

Figure 6.7-8. BER vs. E_b/N_o Curves for DPSK Receiver ($M = 4$) with Off-Tune Pulsed Interference Scenario 1

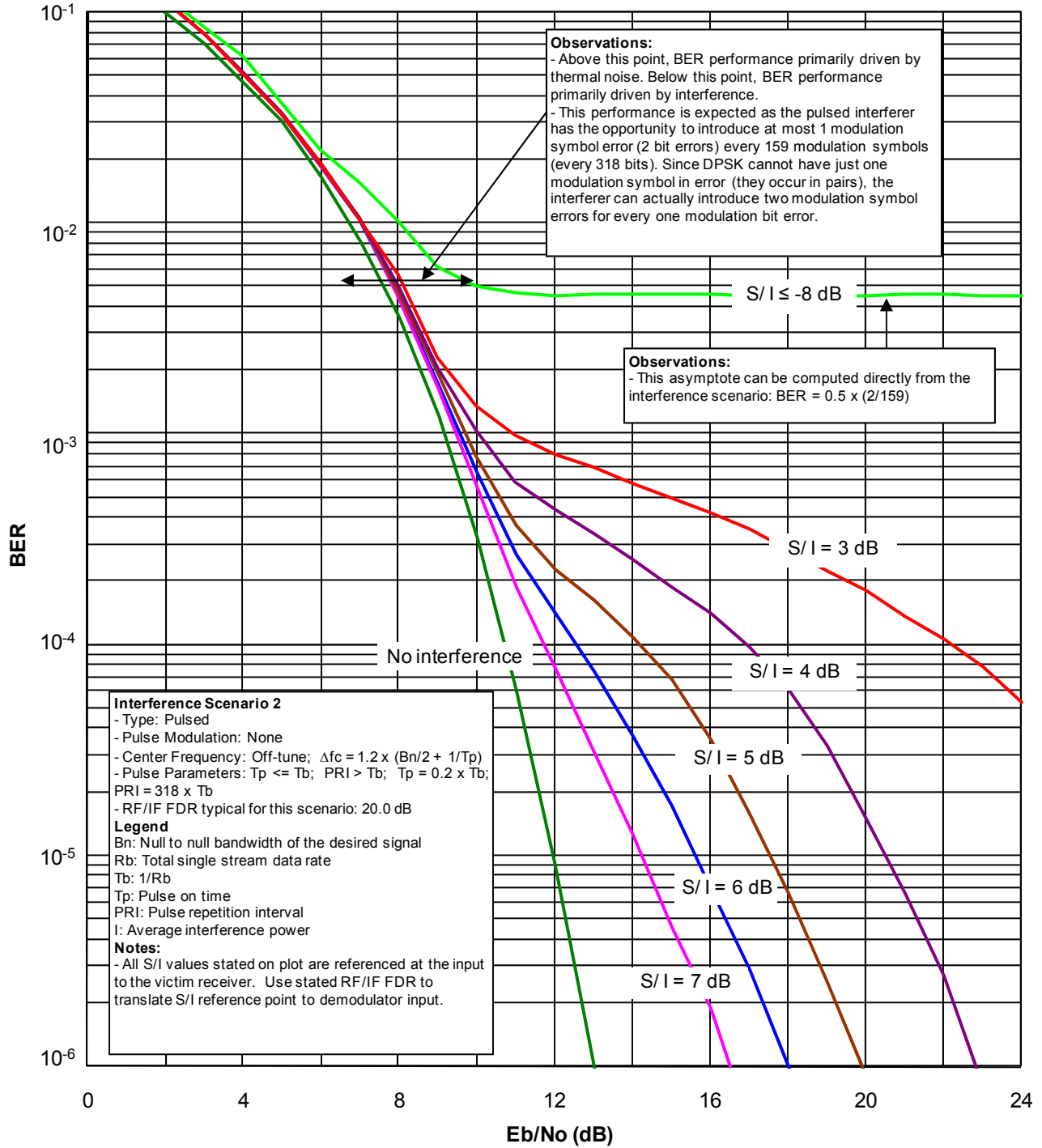

Figure 6.7-9. BER vs. E_b/N_o Curves for DPSK Receiver ($M = 4$) with Off-Tune Pulsed Interference Scenario 2

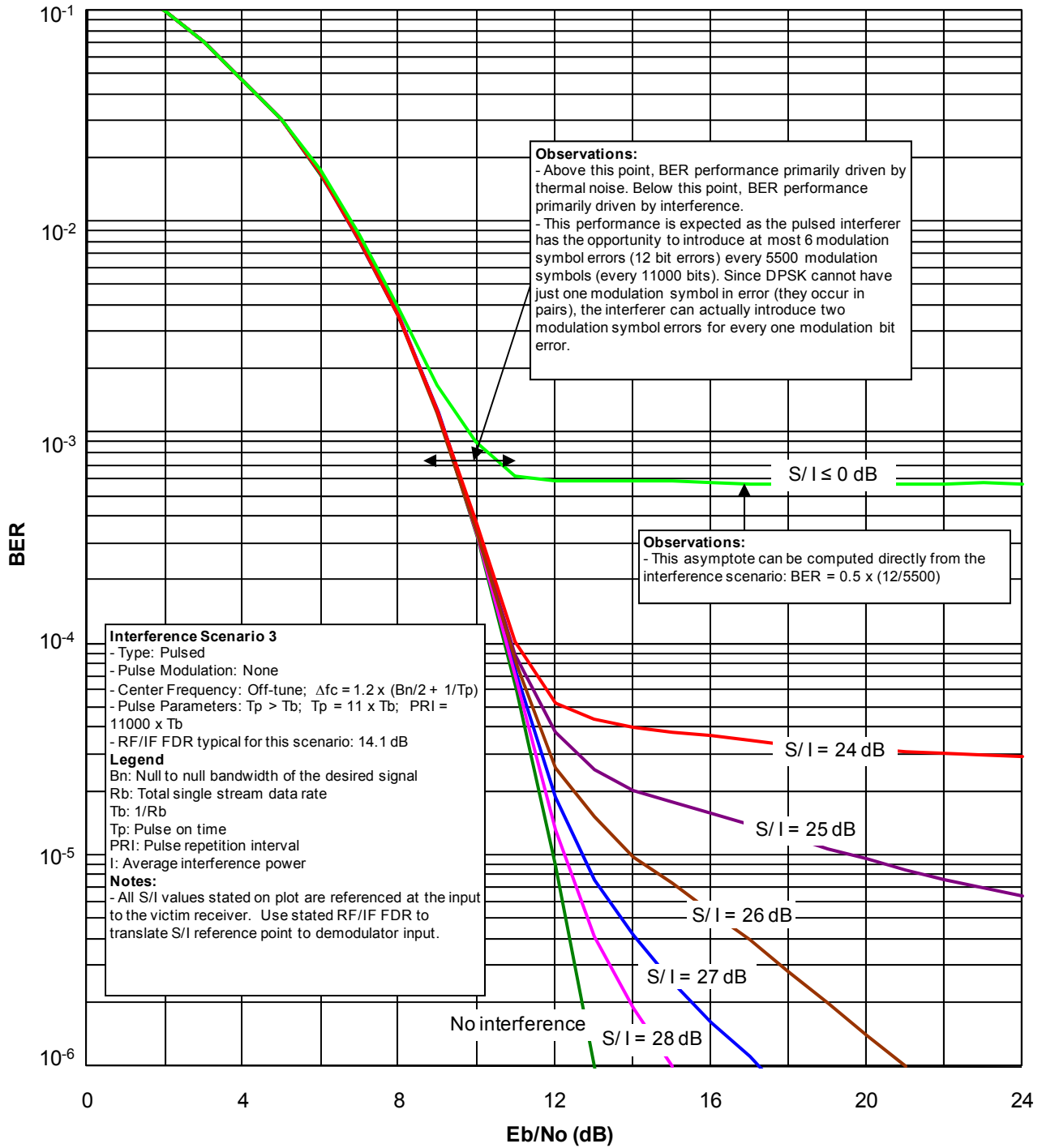

Figure 6.7-10. BER vs. E_b/N_o Curves for DPSK Receiver ($M = 4$) with Off-Tune Pulsed Interference Scenario 3

6.8 FREQUENCY-SHIFT KEYING

6.8.1 Description

FSK uses M different frequencies to transmit the digital data. These signaling frequencies are equally spaced and centered about the RF carrier frequency. The waveform of the FSK signal may be expressed:

$$v_i(t) = A \cos(2\pi f_i t) \quad (6-28)$$

where

$$f_i = \text{symbol frequency, in Hz.}$$

The separation between adjacent frequencies ($\Delta f = f_i - f_{i-1}$) affects the required bandwidth and the BER. The optimum (smallest) BER occurs when the signaling frequencies are orthogonal. The frequencies are orthogonal when $2\Delta f$ is an integer multiple of the symbol rate R_s .

Coherent reception means that the demodulator is phase-locked to the received signal. For noise and noise-like interference, the BER for coherent FSK (CFSK) is:

$$BER = \frac{M-1}{2} \operatorname{erfc} \left(\sqrt{\frac{k E_b}{2 N_o}} \right) \quad (6-29)$$

This equation assumes orthogonal signaling frequencies.

The FSK demodulator can be simplified by employing two bandpass filters to noncoherently detect the signaling frequencies. Such a scheme results in degraded performance relative to coherent detection. For noise and noise-like interference, the SER for noncoherent FSK (NCFSK) is:

$$SER = \sum_{j=1}^{M-1} (-1)^{j+1} \frac{(M-1)!}{j!(M-1-j)!} \frac{1}{j+1} \exp \left(-\frac{jk E_b}{j+1 N_o} \right) \quad (6-30)$$

Equation 6-13 can be used with Equation 6-30 to estimate the BER for noncoherent FSK. For the binary case ($k = 1$ and $M = 2$), Equation 6-30 reduces to:

$$BER = \frac{1}{2} \exp \left(-\frac{1 E_b}{2 N_o} \right) \quad (6-31)$$

6.8.2 BER Curves

Figure 6.8-1 shows BER curves for a binary CFSK receiver. Figures 6.8-2, 6.8-3, and 6.8-4 show BER curves for a NCFSK receiver with $M = 2$, $M = 4$, and $M = 8$, respectively. In these graphs, the term “interference” and the variable I refer to CW interference. Any noise-like interference power is simply assumed to be added (in mW) to the noise power. For example, suppose there are two interfering signals: a CW signal and a noise-like signal. The S/I parameter is the ratio of the desired signal power to the CW interfering signal power, and the x-axis variable E_b/N_o is calculated with Equation 6-4, where N is the total noise-like power (including the receiver noise and the noise-like interfering signal).

The curves were generated from analytic expressions. The expressions involving CW interference required numerical integration. Each figure displays six curves. Each curve is a plot of BER vs.

E_b/N_0 . The curve labeled “No interference” applies to the case in which there is no CW interference. The other five curves are for cases with CW interference. Each of those five curves is labeled with the S/I for that curve. In all cases, the CW interference was close in frequency to one of the M signaling frequencies. As expected, each curve shows that the BER decreases as the E_b/N_0 increases. As also expected, for a given E_b/N_0 the BER decreases as the S/I increases.

Figures 6.8-5, 6.8-6, and 6.8-7 show BER curves for a binary NCFSK receiver with various on-tune pulsed interference scenarios (as annotated on the plots).

Figures 6.8-8 and 6.8-9 show BER curves for a binary NCFSK receiver with various off-tune pulsed interference scenarios (as annotated on the plots).

Figure 6.8-10 shows BER curves for a binary FSK receiver with an interferer identical to the victim signal (i.e., two user signals competing for the same frequency).

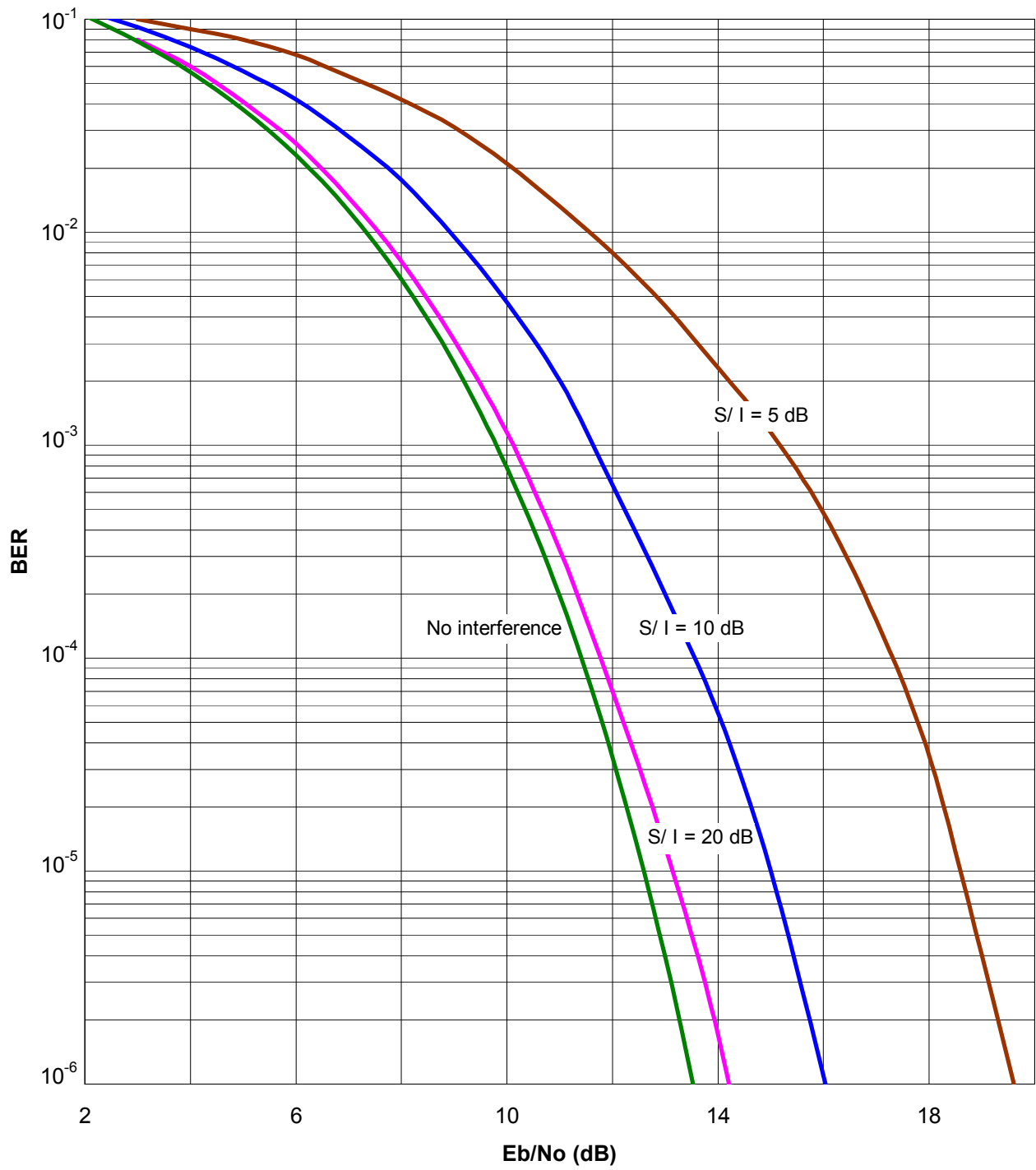

Figure 6.8-1. BER vs. E_b/N_o Curves for CFSK Receiver ($M = 2$) with CW Interference

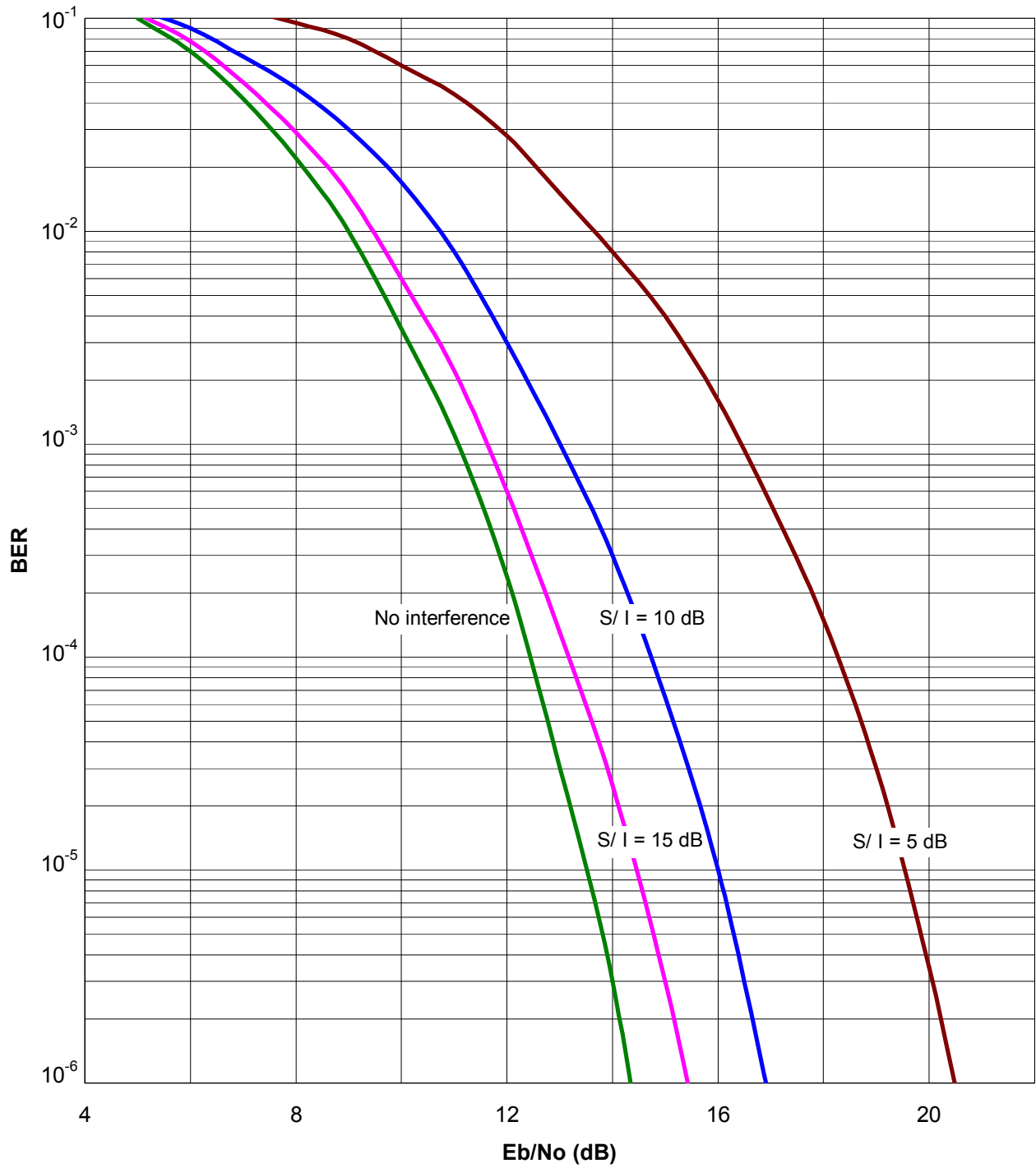

Figure 6.8-2. BER vs. E_b/N_0 Curves for NCFSK Receiver ($M = 2$) with CW Interference

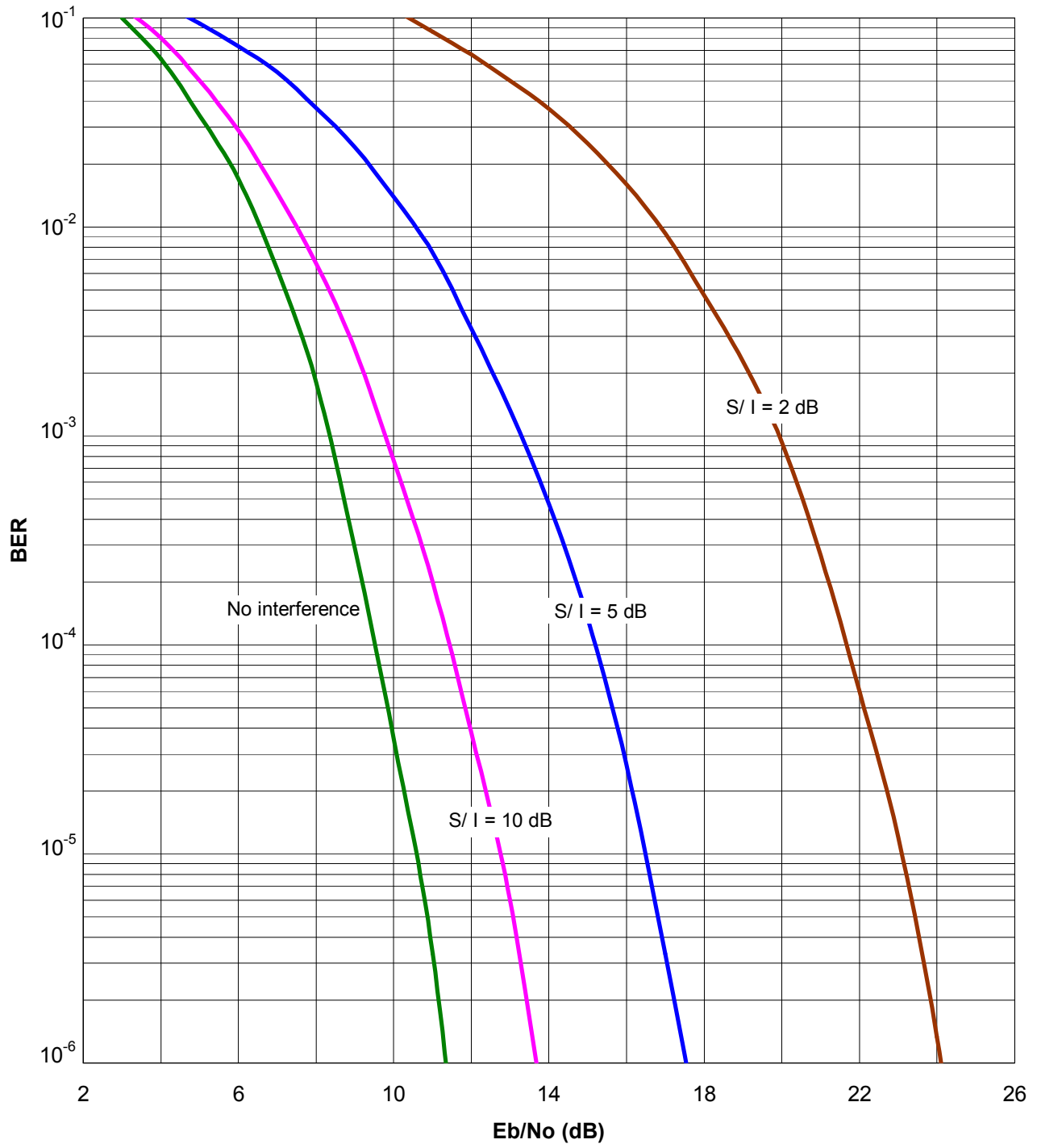

Figure 6.8-3. BER vs. E_b/N_o Curves for NCFSK Receiver ($M = 4$) with CW Interference

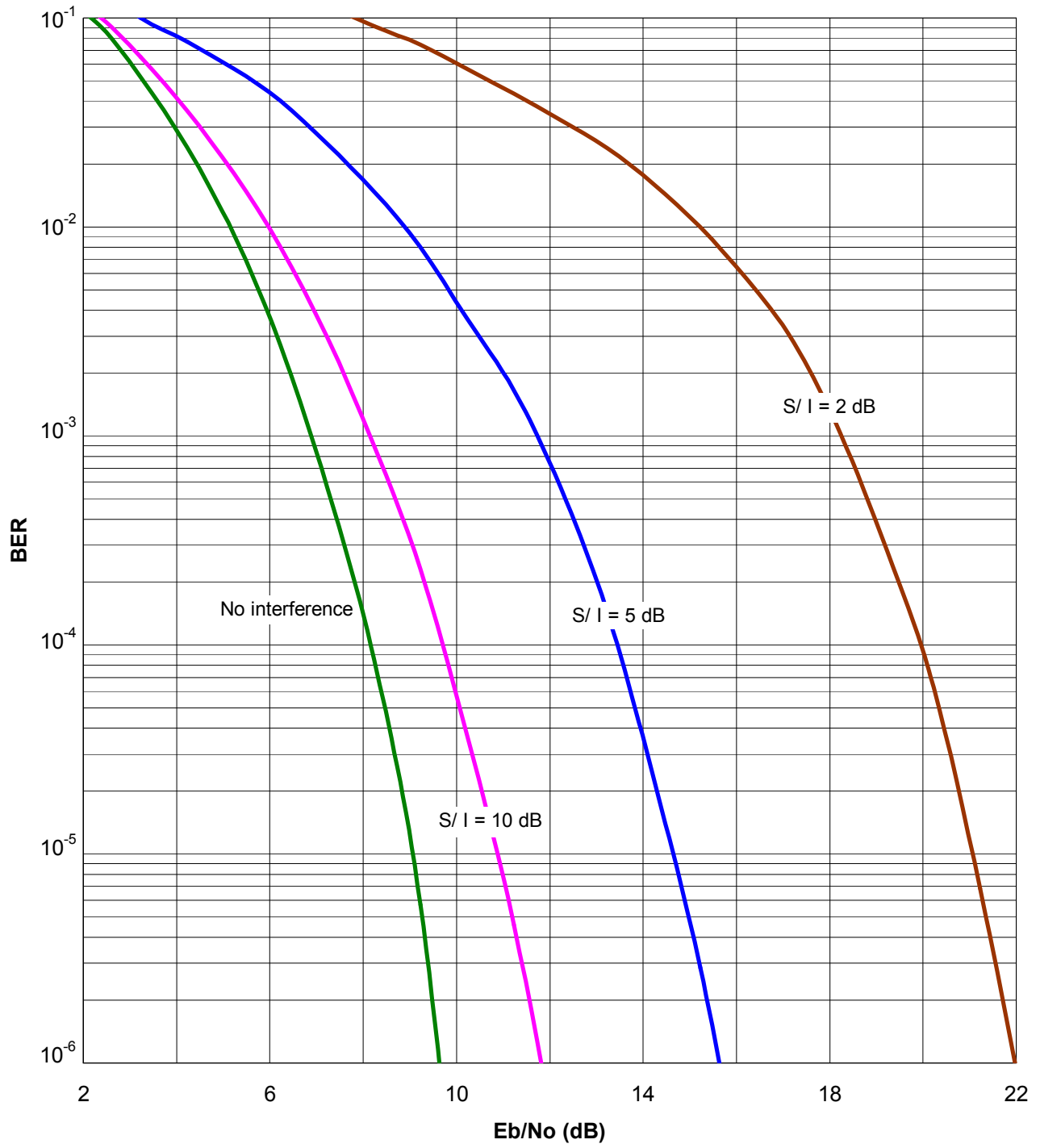

Figure 6.8-4. BER vs. E_b/N_o Curves for NCFSK Receiver ($M = 8$) with CW Interference

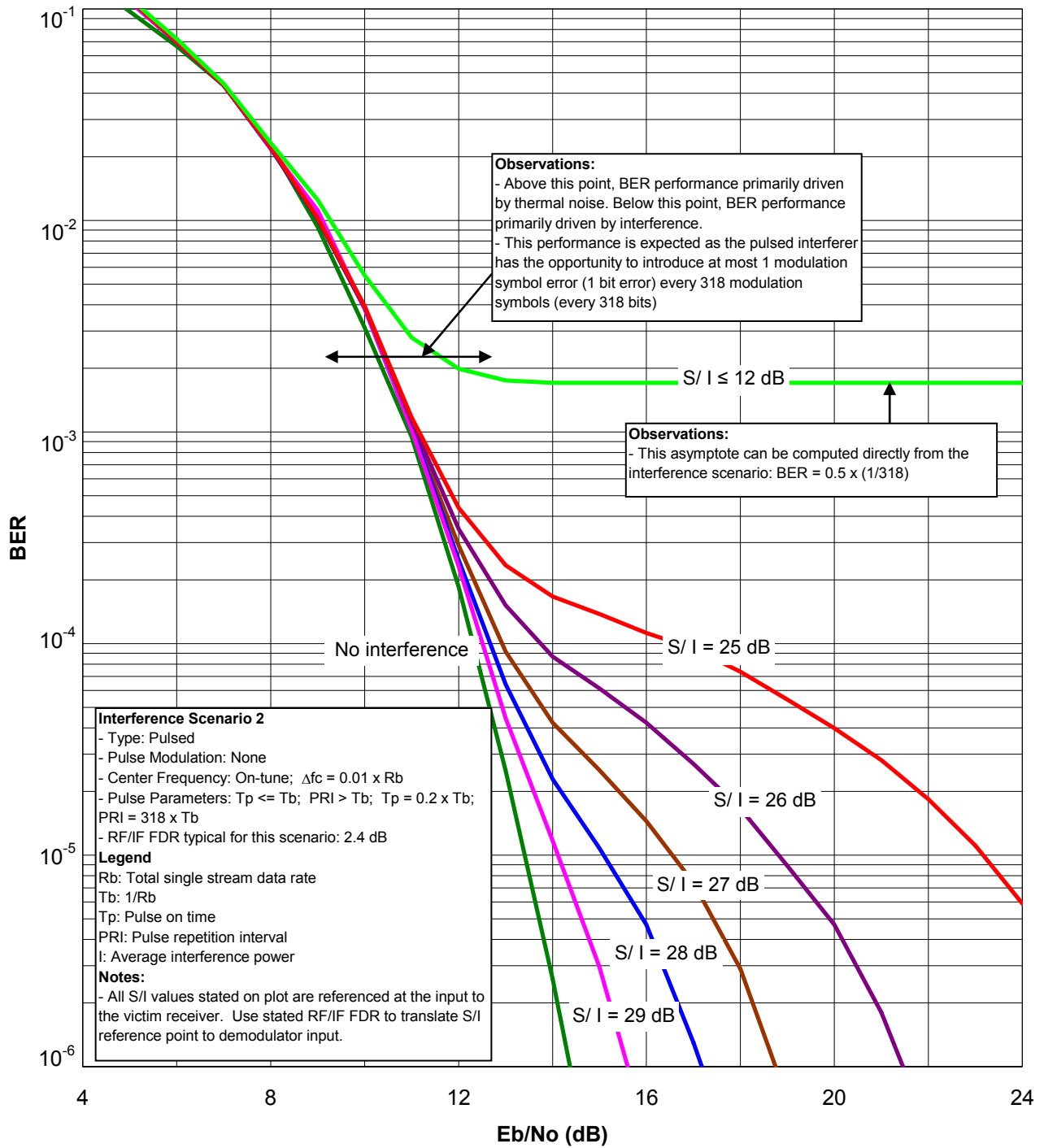

Figure 6.8-5. BER vs. E_b/N_o Curves for NCFSK Receiver ($M = 2$) with On-Tune Pulsed Interference Scenario 2

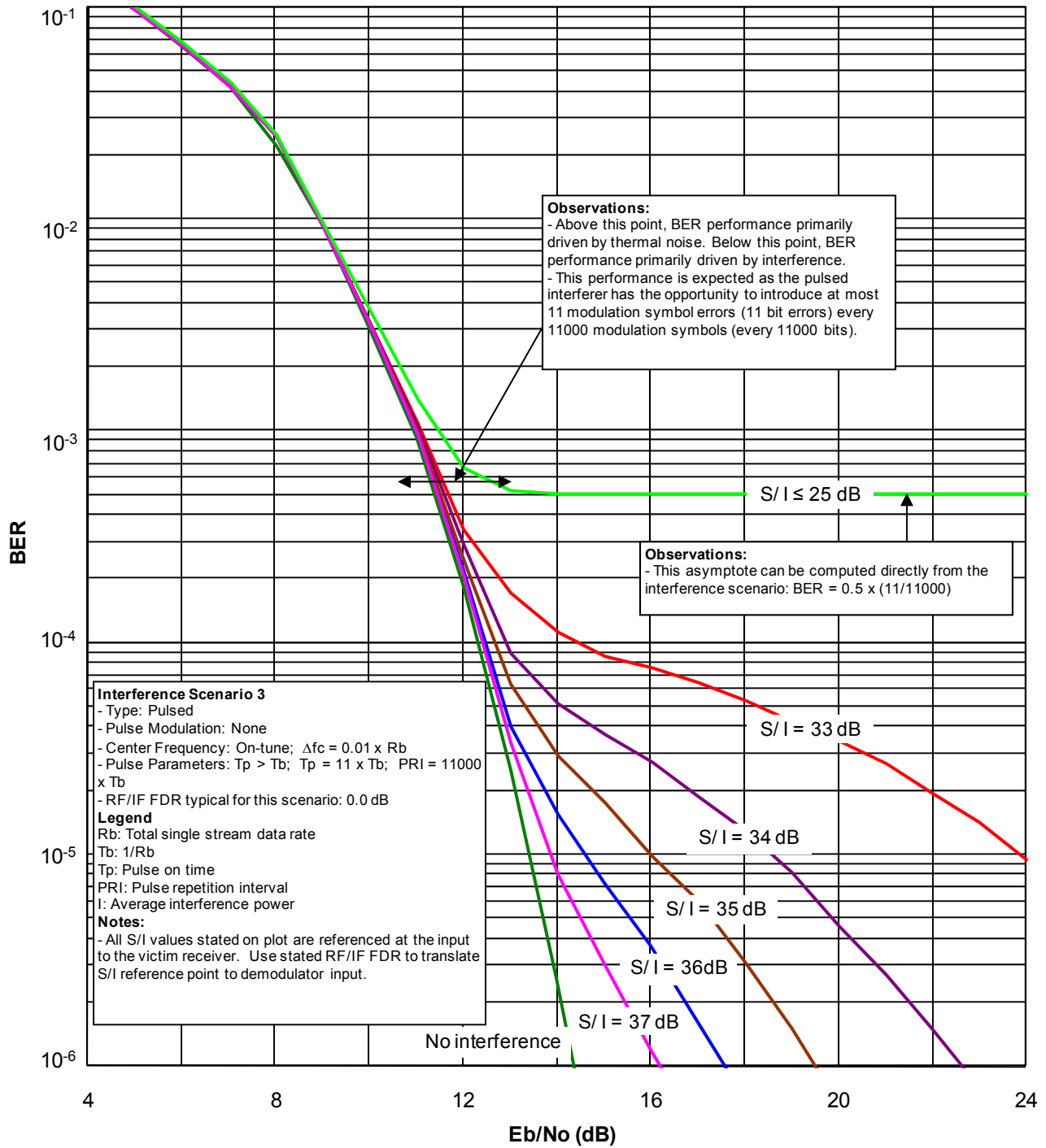

Figure 6.8-6. BER vs. E_b/N_o Curves for NCFSK Receiver ($M = 2$) with On-Tune Pulsed Interference Scenario 3

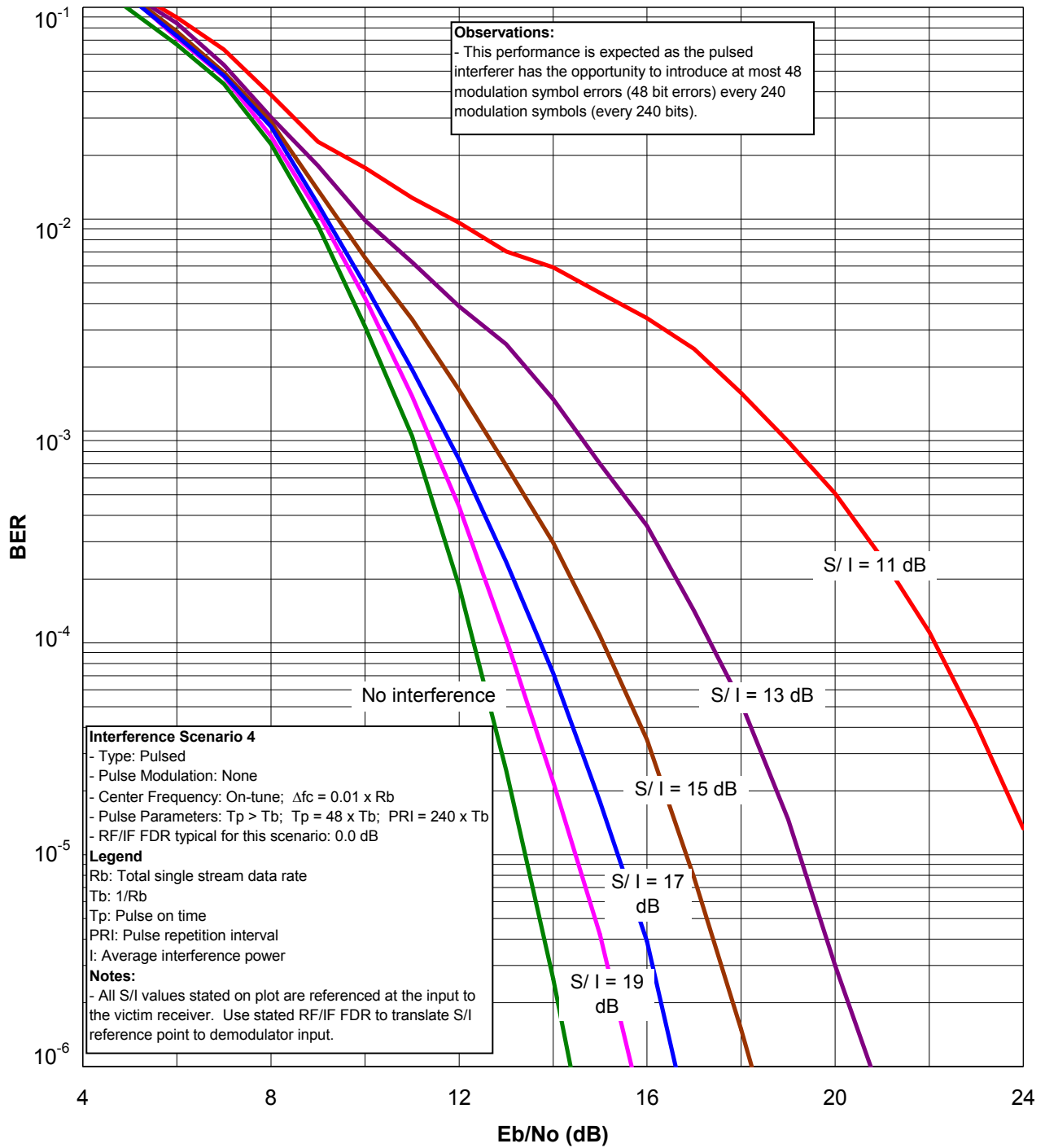

Figure 6.8-7. BER vs. E_b/N_o Curves for NCFSK Receiver ($M = 2$) with On-Tune Pulsed Interference Scenario 4

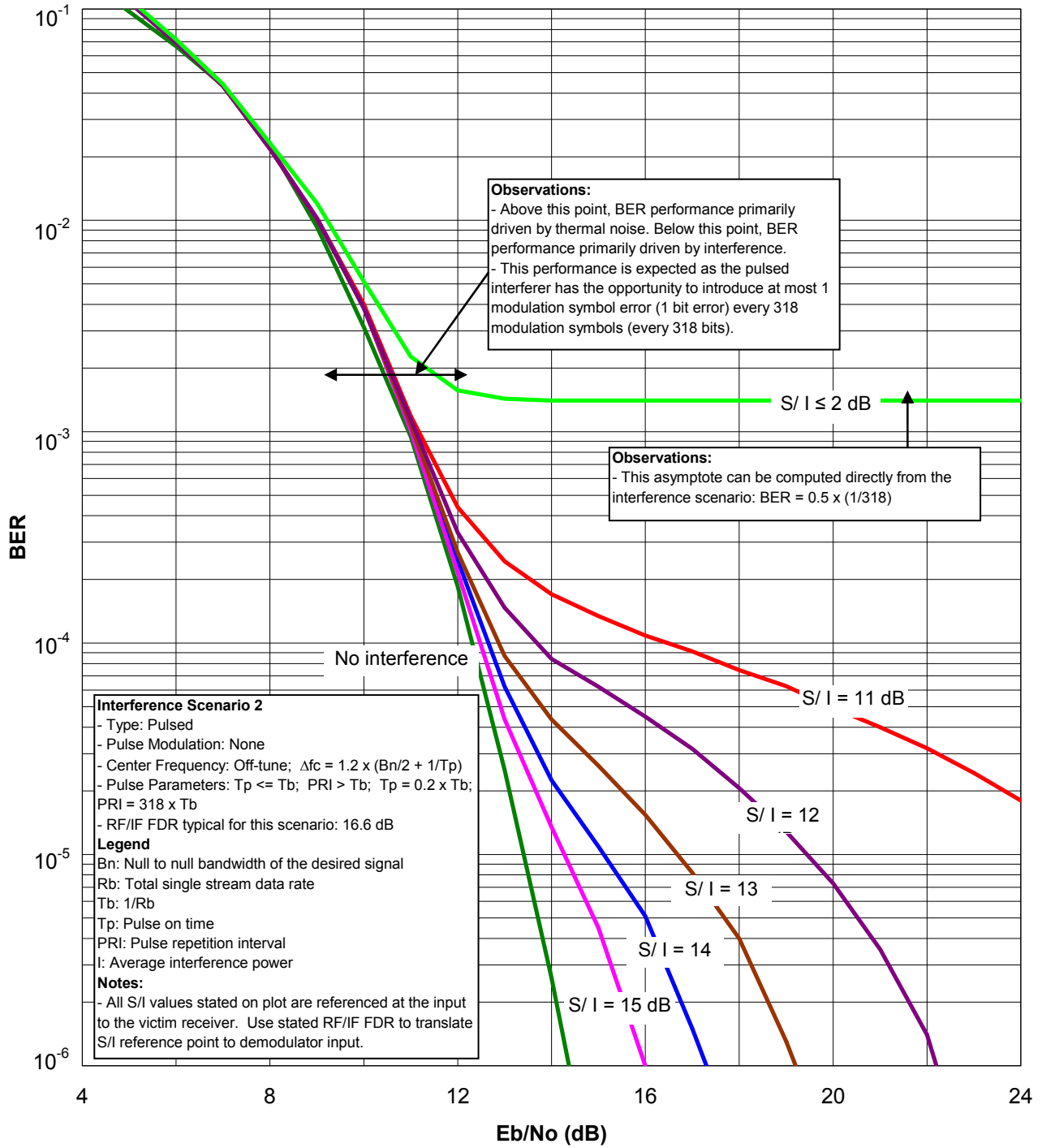

Figure 6.8-8. BER vs. E_b/N_o Curves for NCFSK Receiver ($M = 2$) with Off-Tune Pulsed Interference Scenario 2

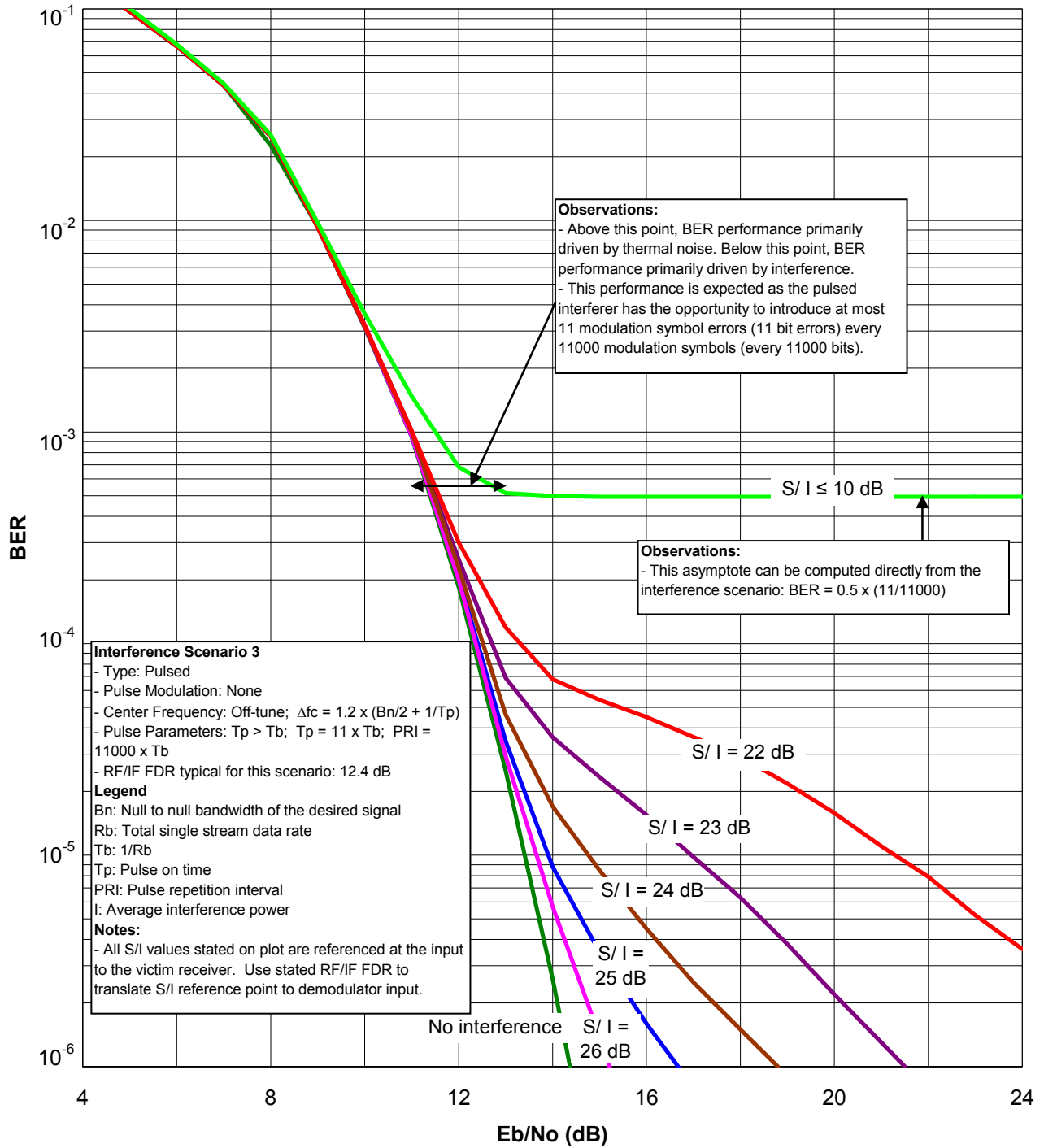

Figure 6.8-9. BER vs. E_b/N_o Curves for NCFSK Receiver ($M = 2$) with Off-Tune Pulsed Interference Scenario 3

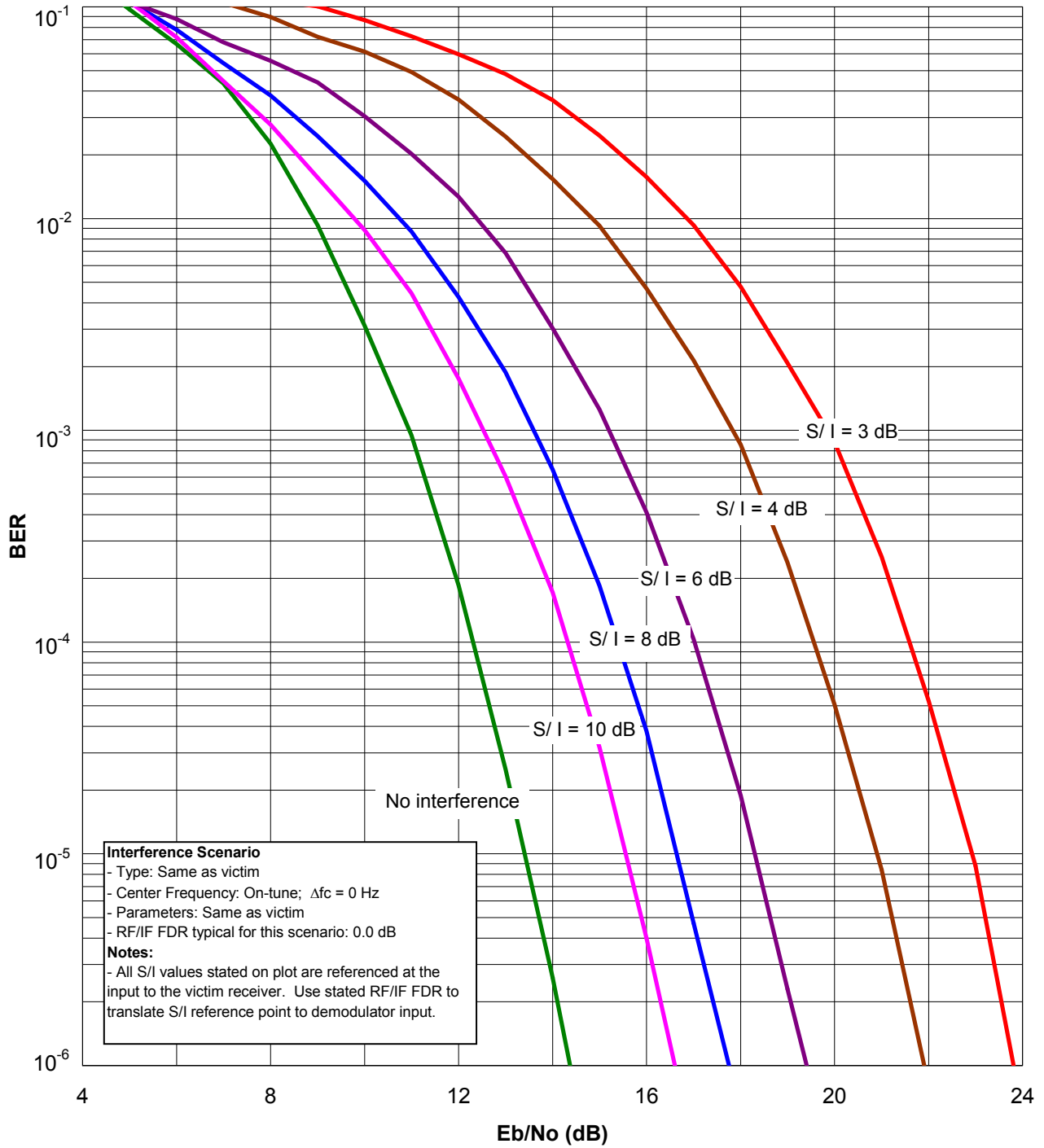

Figure 6.8-10. BER vs. E_b/N_o Curves for NCFSK Receiver ($M = 2$) with Same as Victim Interference

6.9 MINIMUM-SHIFT KEYING

6.9.1 Description

A Minimum Shift Keying (MSK) waveform can be represented as an FSK waveform with the two signaling frequencies separated by $R_b/2$. This is the minimum separation that allows orthogonality. MSK can also be represented as a form of QPSK, with the additional specifications that:

- The quadrature carriers are offset in time by T_b (offset QPSK or OQPSK),
- Even bits appear on the in-phase channel and odd bits appear on the quadrature channel, and
- The baseband (modulating) pulses are sinusoidal, rather than rectangular.

Because of the waveform complexity, it is necessary to give the waveform of the entire bit sequence rather than the waveform for a single bit. The entire MSK waveform is:

$$v(t) = A \left[\sum_{n=-\infty}^{\infty} I_{2n} u(t - 2nT_b) \right] \cos(2\pi f_c t) + A \left[\sum_{n=-\infty}^{\infty} I_{2n+1} u(t - [2n+1]T_b) \right] \sin(2\pi f_c t) \quad (6-32)$$

where

$\sum_{n=-\infty}^{\infty} I_{2n}$ represents the sequence of even-numbered information bits ($I_{2n} = \pm 1$)

$\sum_{n=-\infty}^{\infty} I_{2n+1}$ represents the sequence of odd-numbered information bits ($I_{2n+1} = \pm 1$)

The sinusoidal pulse-shaping function is:

$$u(t) = \sin(\pi t / 2T_b) \quad 0 \leq t \leq 2T_b \quad (6-33)$$

Note that $u(t)$ extends over two bit intervals. These MSK properties eliminate phase discontinuities that would otherwise occur when the waveform changes state in accordance with the modulating signal. For this reason, MSK is more spectrally efficient than either standard QPSK or OQPSK with rectangular modulating pulses.

This expression for the MSK waveform clearly shows the information bits, the pulse-shaping function, and the quadrature carriers. A variety of modulation types can be derived from OQPSK by varying the pulse-shaping function. Some communications systems are capable of varying the pulse-shaping function in response to operational conditions.

The BER for MSK is the same as for standard QPSK:

$$BER = \frac{1}{2} \operatorname{erfc} \left(\sqrt{\frac{E_b}{N_o}} \right) \quad (6-34)$$

6.9.2 BER Curves

Figure 6.9-1 shows BER curves for an MSK receiver. In this graph, the term “interference” and the variable I refer to CW interference. Any noise-like interference power is simply assumed to be added (in mW) to the noise power. For example, suppose there are two interfering signals: a CW signal and a noise-like signal. The S/I parameter is the ratio of the desired signal power to the CW

interfering signal power, and the x-axis variable E_b/N_o is calculated with Equation 6-4, where N is the total noise-like power (including the receiver noise and the noise-like interfering signal).

The curves are the same as the QPSK curves, which were generated from analytic expressions. The expressions involving CW interference required numerical integration. The figure displays six curves. Each curve is a plot of BER vs. E_b/N_o . The curve labeled “No interference” applies to the case in which there is no CW interference. The other five curves are for cases with CW interference. Each of those five curves is labeled with the S/I for that curve. As expected, each curve shows that the BER decreases as the E_b/N_o increases. As also expected, for a given E_b/N_o the BER decreases as the S/I increases.

Figures 6.9-2, 6.9-3, and 6.9-4 show BER curves for a MSK receiver with various on-tune pulsed interference scenarios (as annotated on the plots).

Figures 6.9-5 and 6.9-6 show BER curves for a MSK receiver with various off-tune pulsed interference scenarios (as annotated on the plots).

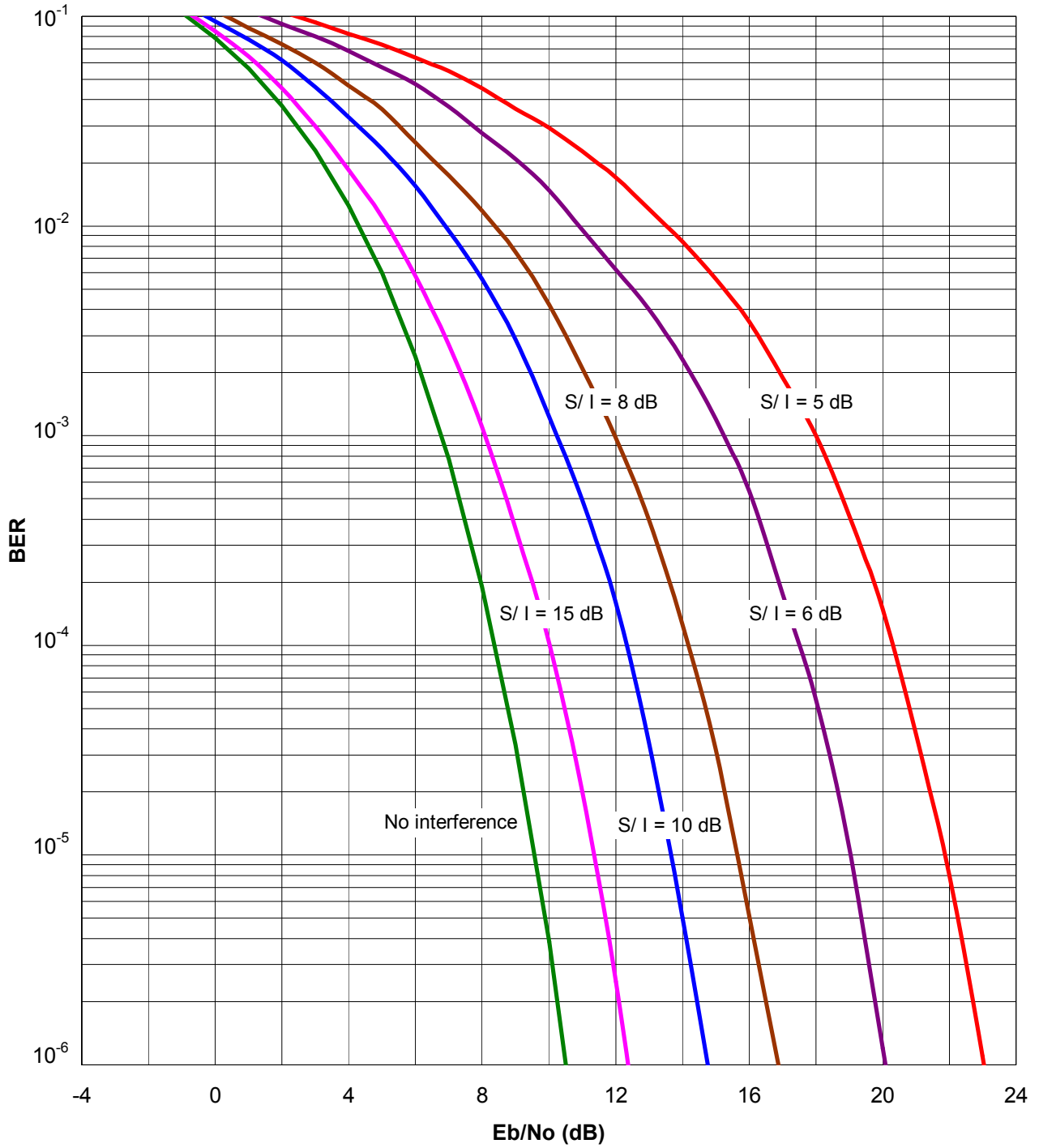

Figure 6.9-1. BER Curves for an MSK Receiver with CW Interference

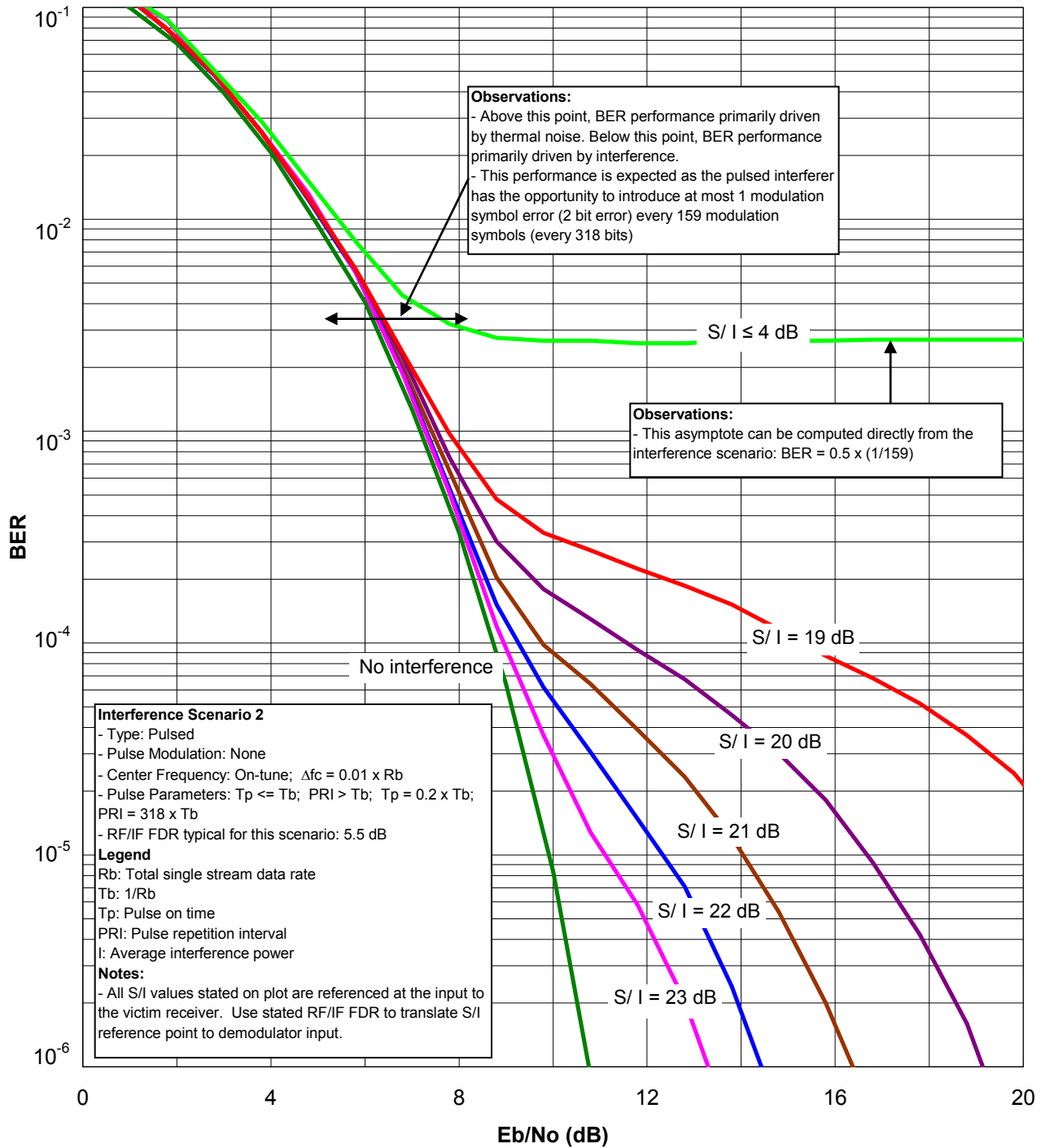

Figure 6.9-2. BER vs. E_b/N_o Curves for MSK Receiver with On-Tune Pulsed Interference Scenario 2

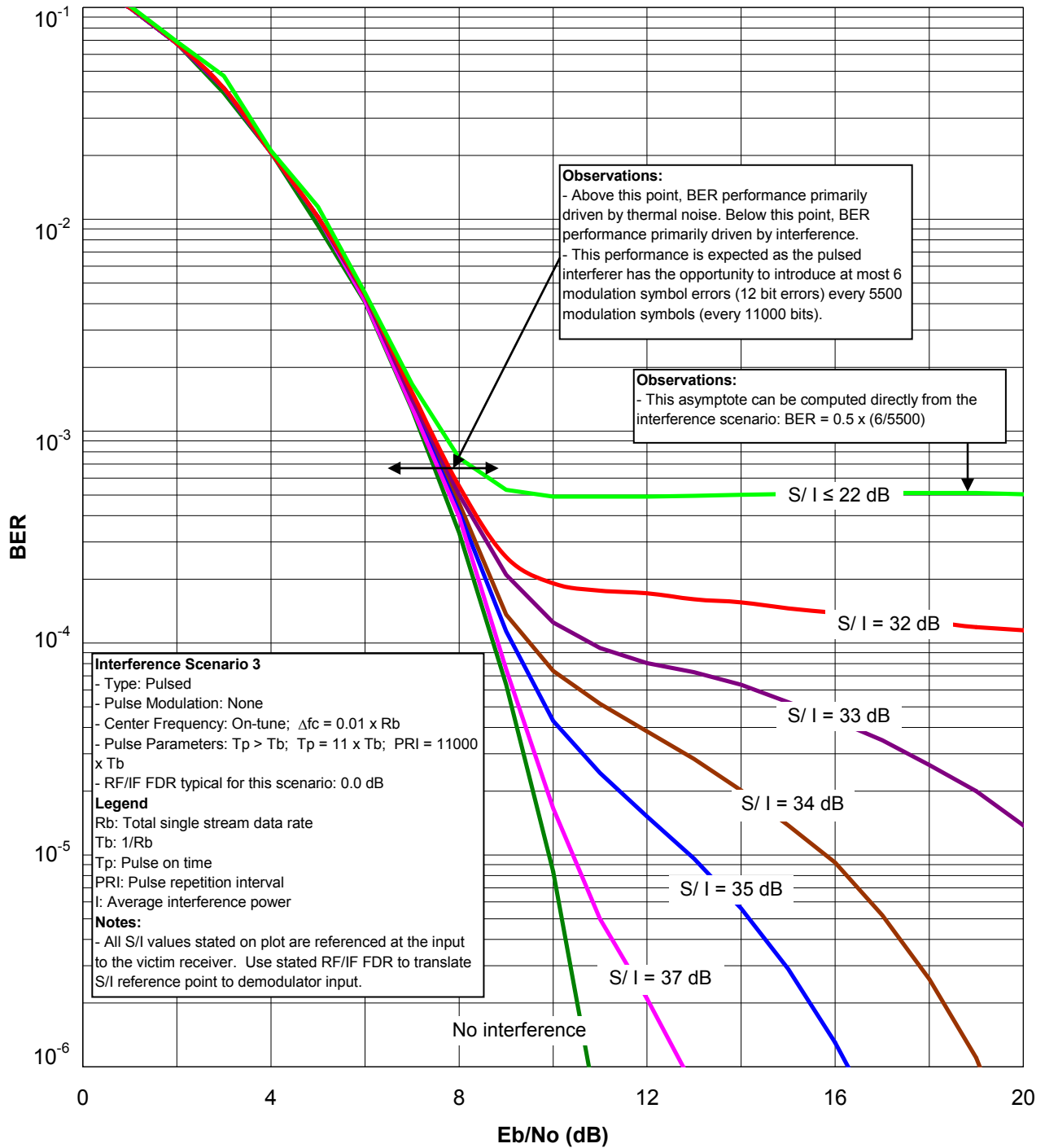

Figure 6.9-3. BER vs. E_b/N_o Curves for MSK Receiver with On-Tune Pulsed Interference Scenario 3

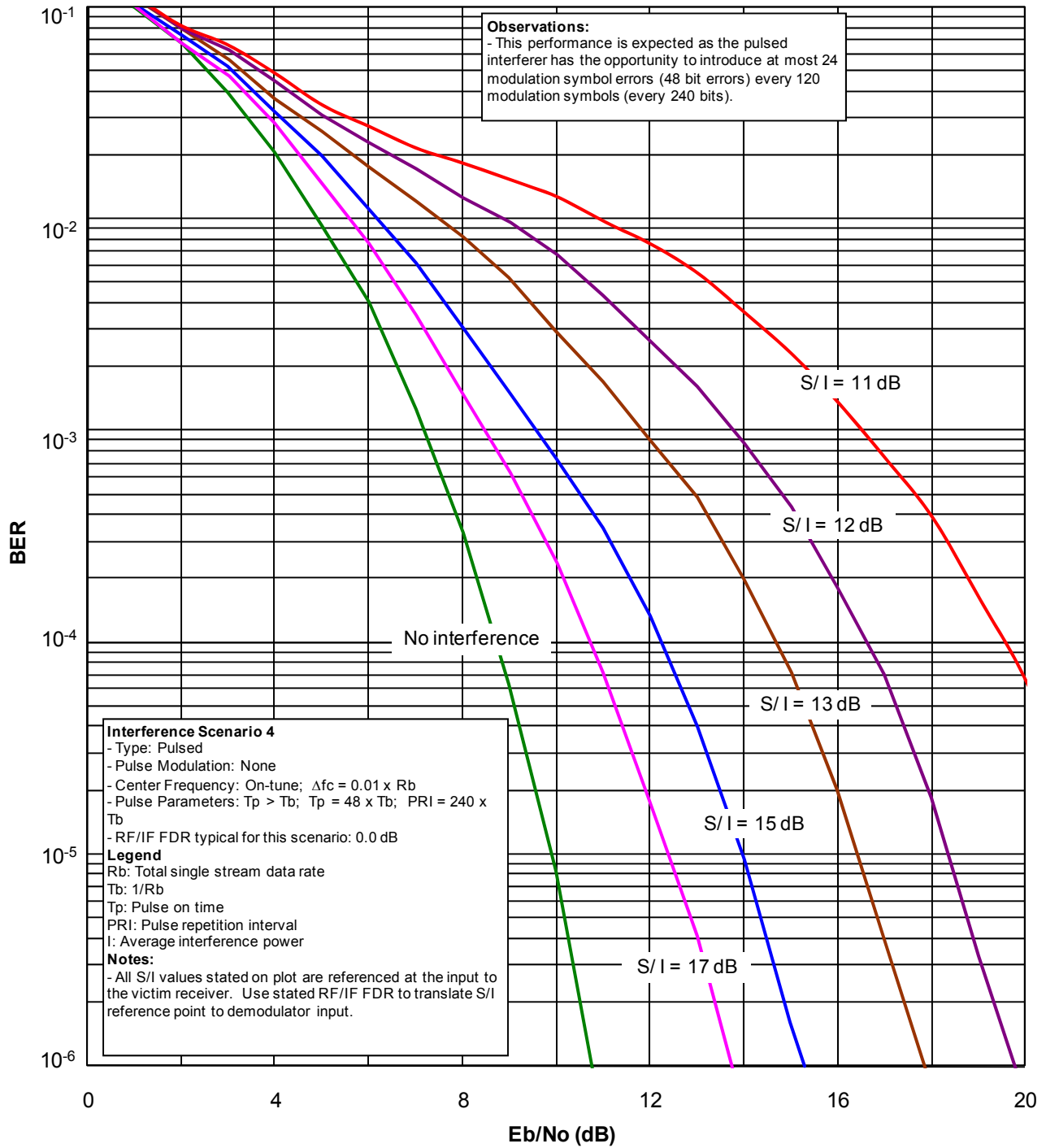

Figure 6.9-4. BER vs. E_b/N_0 Curves for MSK Receiver with On-Tune Pulsed Interference Scenario 4

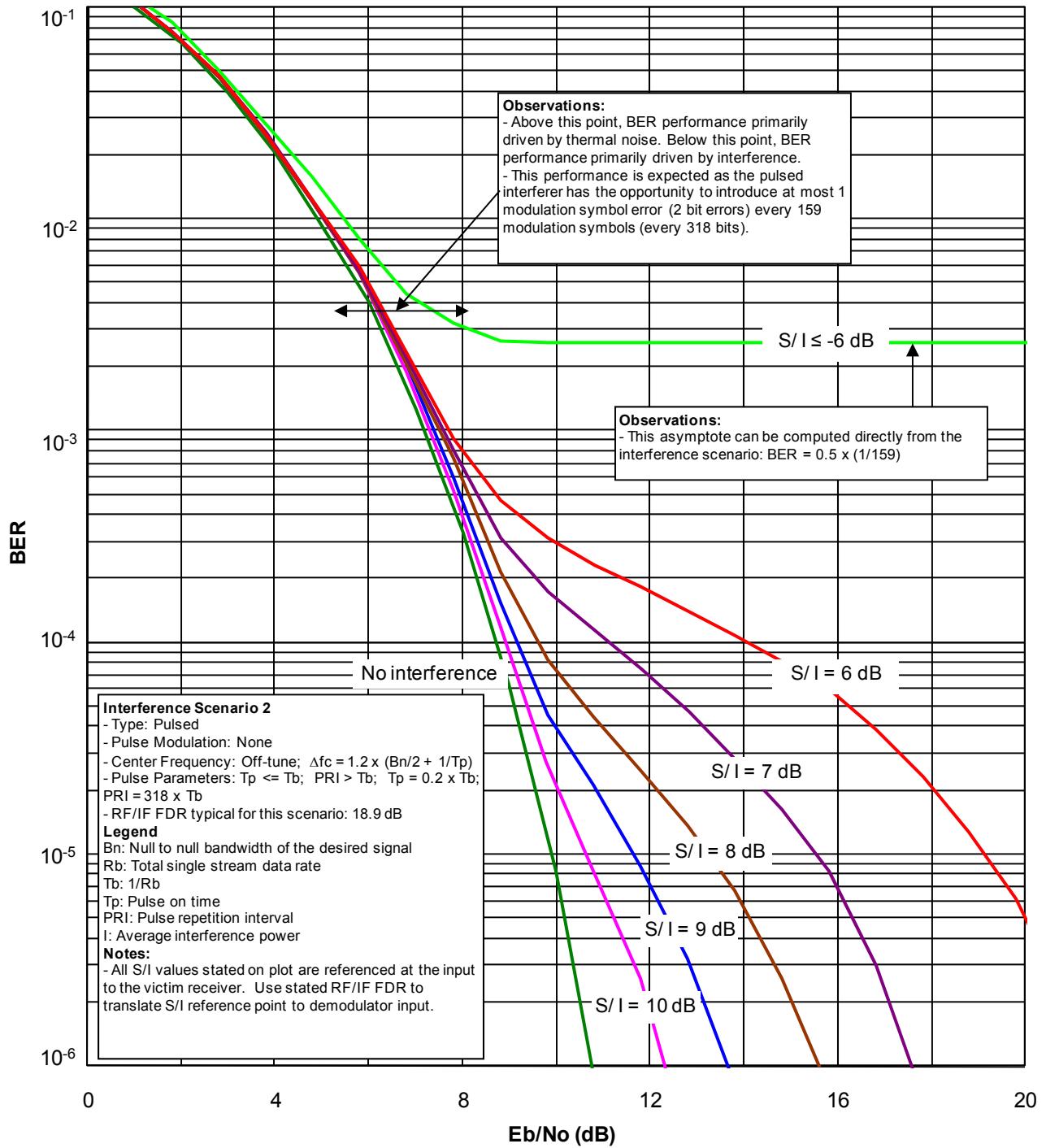

Figure 6.9-5. BER vs. E_b/N_o Curves for MSK Receiver with Off-Tune Pulsed Interference Scenario 2

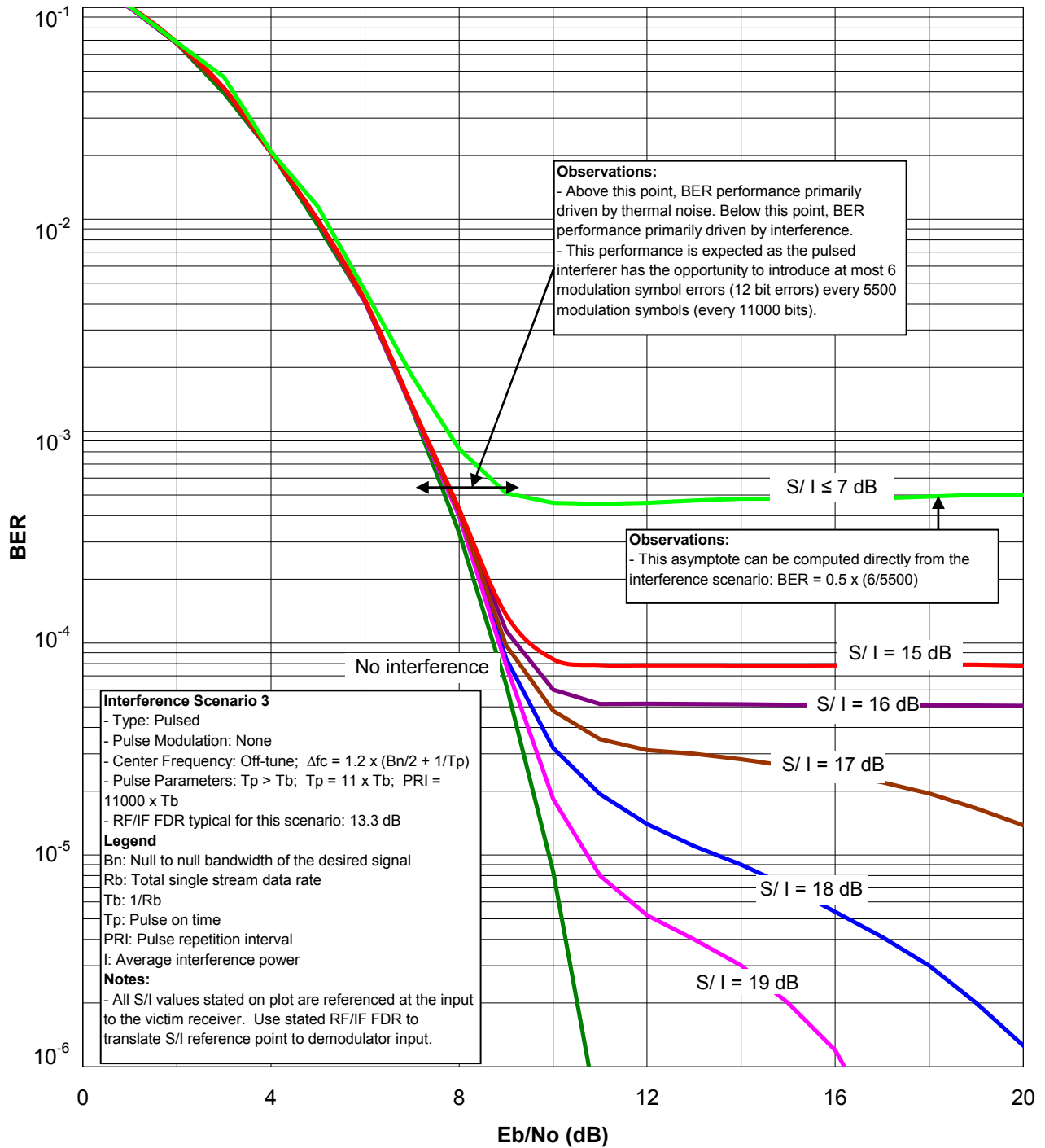

Figure 6.9-6. BER vs. E_b/N_o Curves for MSK Receiver with Off-Tune Pulsed Interference Scenario 3

6.10 QUASI-BANDLIMITED MINIMUM-SHIFT KEYING

6.10.1 Description

Quasi-bandlimited Minimum-Shift Keying (QBL-MSK) is a variation of MSK. In the MSK waveform as shown in Equations 6-32 and 6-33, a pulse shaping function $u(t)$ is applied to rectangular pulses that represent the input bit sequence. The pulse-shaping function is used to provide smooth transitions between bit periods, as seen in the time domain. The result of this pulse-shaping, as seen in the frequency domain, is that more of the signal power is concentrated around the RF carrier. This in turn allows for greater bandwidth efficiency, which is the ratio of the bit rate to the bandwidth required for transmission at that bit rate.

Bandwidth efficiency is indirectly related to error performance. While it may be useful to compare the error performance (BER vs. E_b/N_o) of modulation types assuming no band-limiting, any practical system must operate within a predetermined bandwidth. This constraint favors modulation types that have high bandwidth efficiency. For a given bit rate, bandwidth efficiency can be adjusted by employing different pulse-shaping functions.

The wide variety of pulse-shaping functions that have been studied can be classified as constant-envelope or varying-envelope, referring to the modulated RF signal. The type of envelope affects the power efficiency of the communications system. A signal with a non-constant envelope requires linear amplification. If the amplification is not linear, the bandwidth of the signal will be increased. Linear amplification is not required for signals with a constant-envelope. A typical amplifier is linear over only part of its operating range. Consequently, a signal with a non-constant envelope can utilize only a portion of the available operating range of an amplifier.

Certain pulse-shaping functions that exhibit high bandwidth efficiency result in modulated signals that have non-constant envelopes. This property reduces the power efficiency of the transmitter. Either a more linear or a more powerful amplifier will be required, or else the transmitted power will be reduced.

Bandwidth efficiency and power efficiency are competing interests for signal designers. Consideration of these interests has led to the development of modulation types that offer a compromise. QBL-MSK is an example of such a modulation type. It offers relatively good bandwidth efficiency, while maintaining the constant-envelope property. Thus, power efficiency is not compromised.

The waveform of the MSK signal includes a sinusoidal pulse-shaping function $u(t)$. For QBL-MSK, the pulse-shaping function is:

$$u(t) = \left(\frac{\sin(\pi t / T_b)}{\pi t / T_b} \right)^n \quad -2T_b \leq t \leq 2T_b \quad (6-35)$$

where typically $n = 3$.

The result of employing this pulse-shaping technique to bandlimit the signal is a modest (2 dB or less) improvement in error-performance with respect to standard MSK. The precise improvement depends on the precise bandwidth.

6.10.2 BER Curves

Figure 6.10-1 shows BER curves for a QBL-MSK receiver with $n = 3$ (Equation 6-35). In this graph, the term “interference” and the variable I refer to CW interference. Any noise-like interference power is simply assumed to be added (in mW) to the noise power. For example, suppose there are two interfering signals: a CW signal and a noise-like signal. The S/I parameter is the ratio of the desired signal power to the CW interfering signal power, and the x-axis variable E_b/N_o is calculated with Equation 6-4, where N is the total noise-like power (including the receiver noise and the noise-like interfering signal).

The curves were generated by simulation. The figure displays three curves. Each curve is a plot of BER vs. E_b/N_o . The curve labeled “No interference” applies to the case in which there is no CW interference. The other two curves are for cases with CW interference. Each of those two curves is labeled with the S/I for that curve. As expected, each curve shows that the BER decreases as the E_b/N_o increases. As also expected, for a given E_b/N_o the BER decreases as the S/I increases.

Figures 6.10-2, 6.10-3, and 6.10-4 show BER curves for a QBL-MSK receiver with various on-tune pulsed interference scenarios (as annotated on the plots).

Figures 6.10-5 and 6.10-6 show BER curves for a QBL-MSK receiver with various off-tune pulsed interference scenarios (as annotated on the plots)

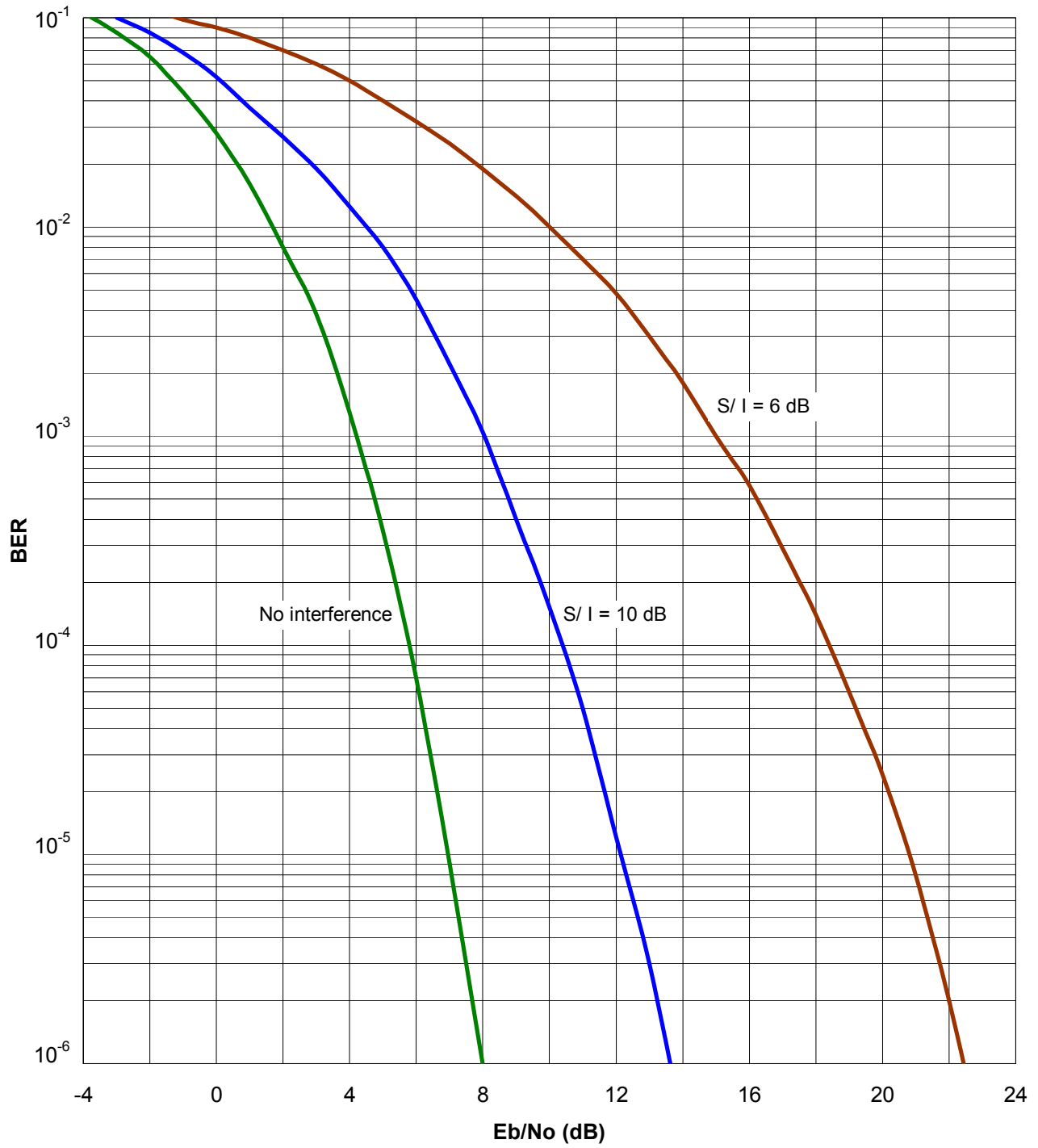

Figure 6.10-1. BER vs. E_b/N_o Curves for QBL-MSK Receiver with CW Interference

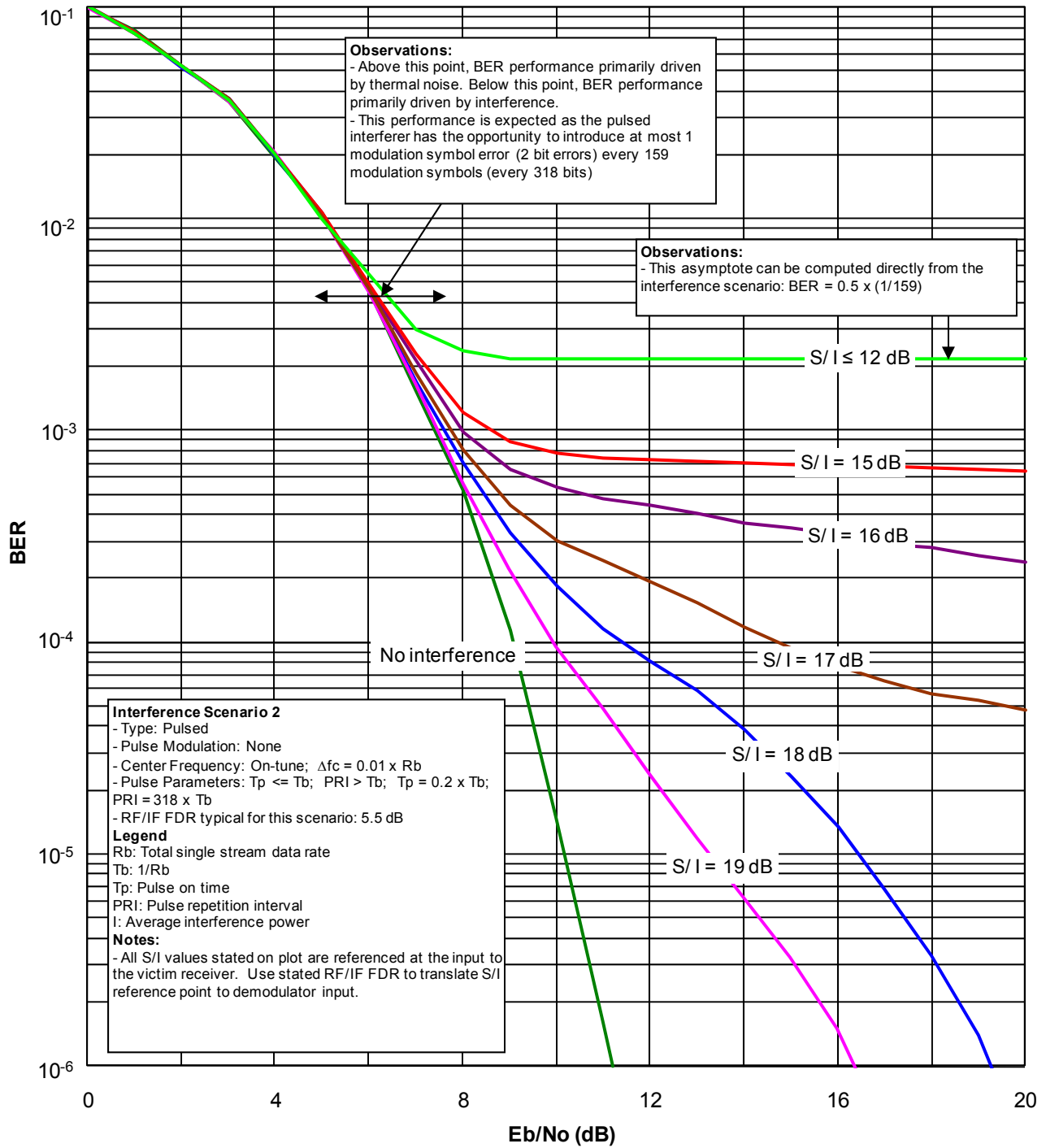

Figure 6.10-2. BER vs. E_b/N_o Curves for QBL-MSK Receiver with On-Tune Pulsed Interference Scenario 2

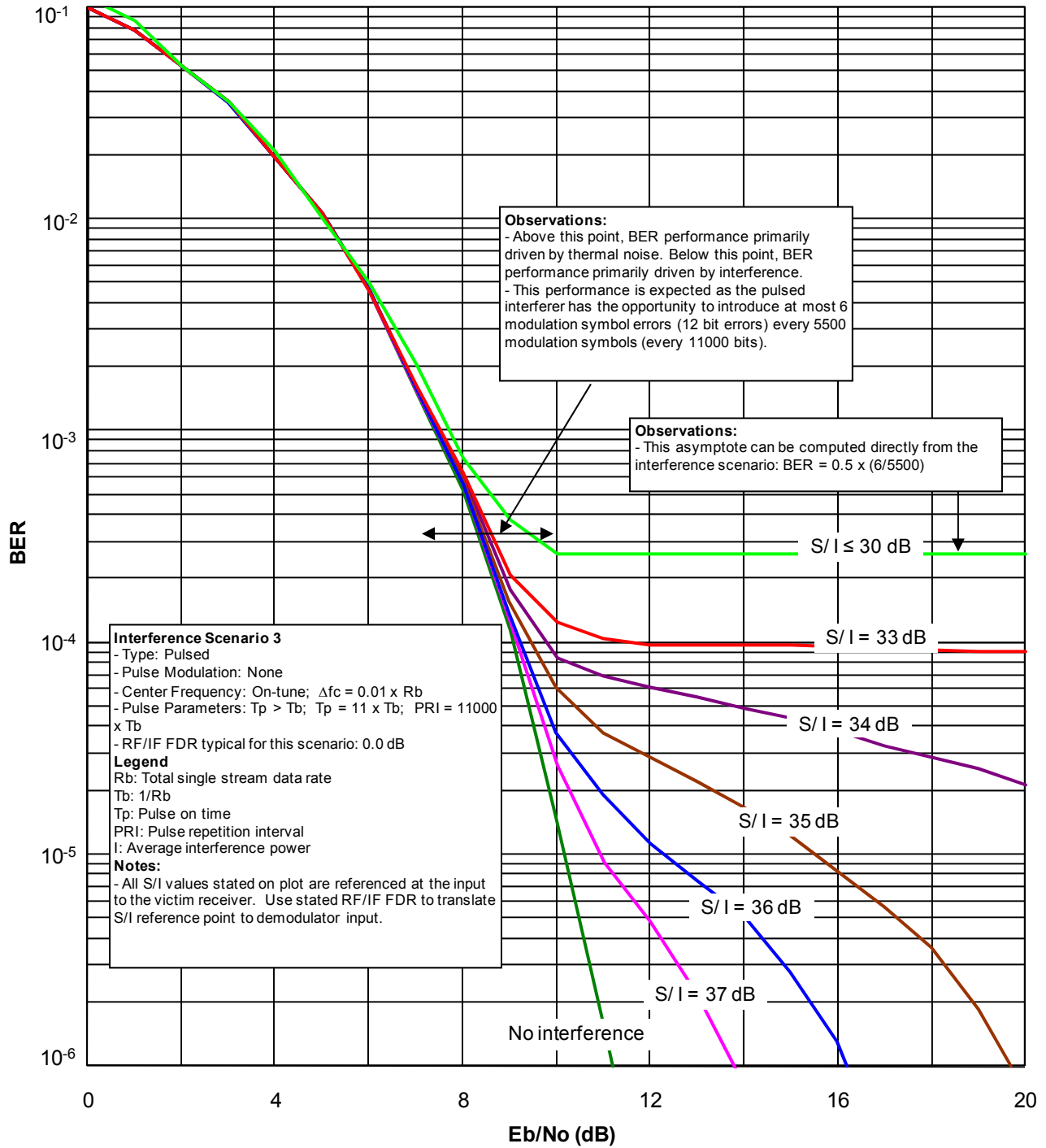

Figure 6.10-3. BER vs. E_b/N_o Curves for QBL-MSK Receiver with On-Tune Pulsed Interference Scenario 3

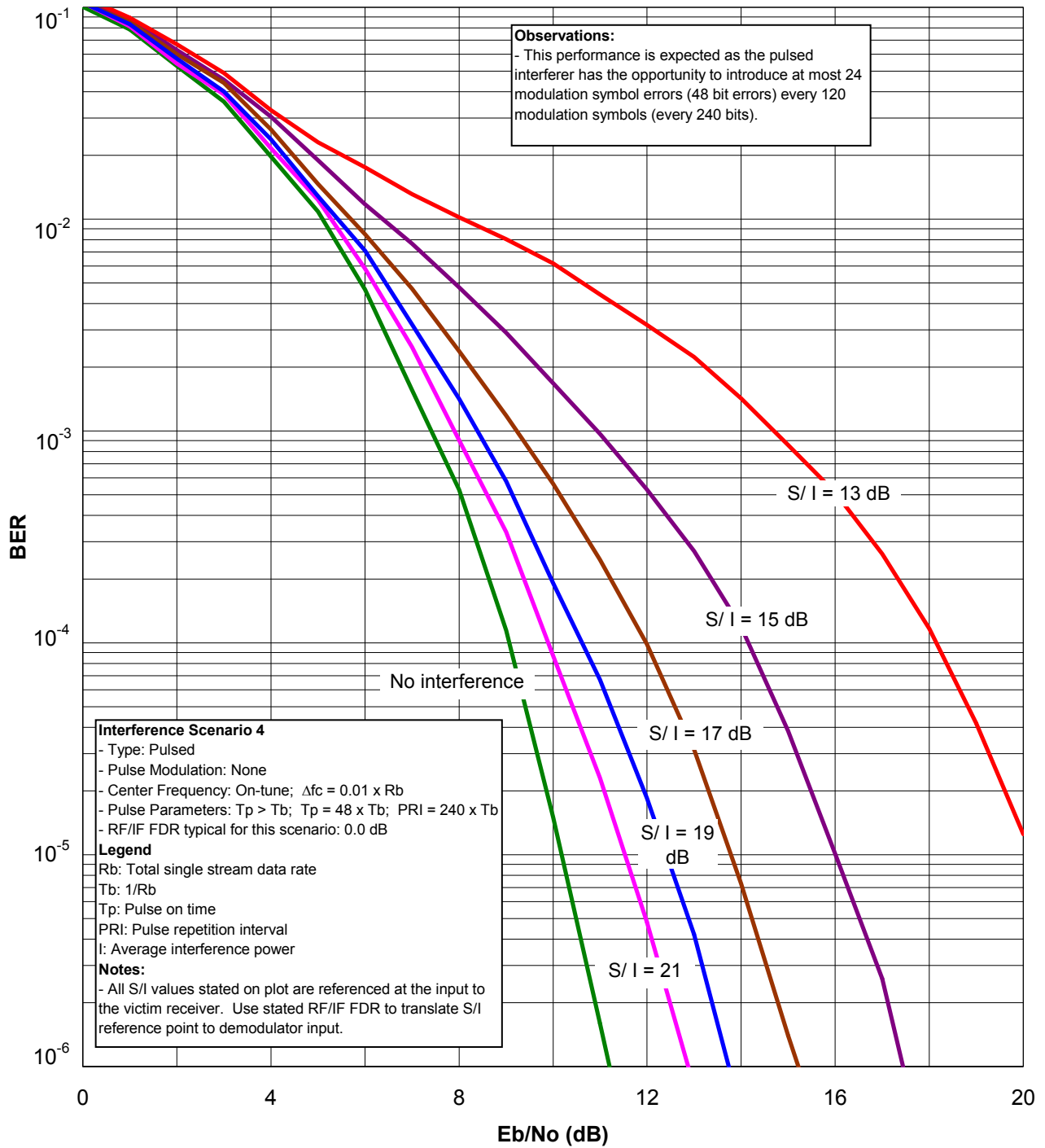

Figure 6.10-4. BER vs. E_b/N_0 Curves for QBL-MSK Receiver with On-Tune Pulsed Interference Scenario 4

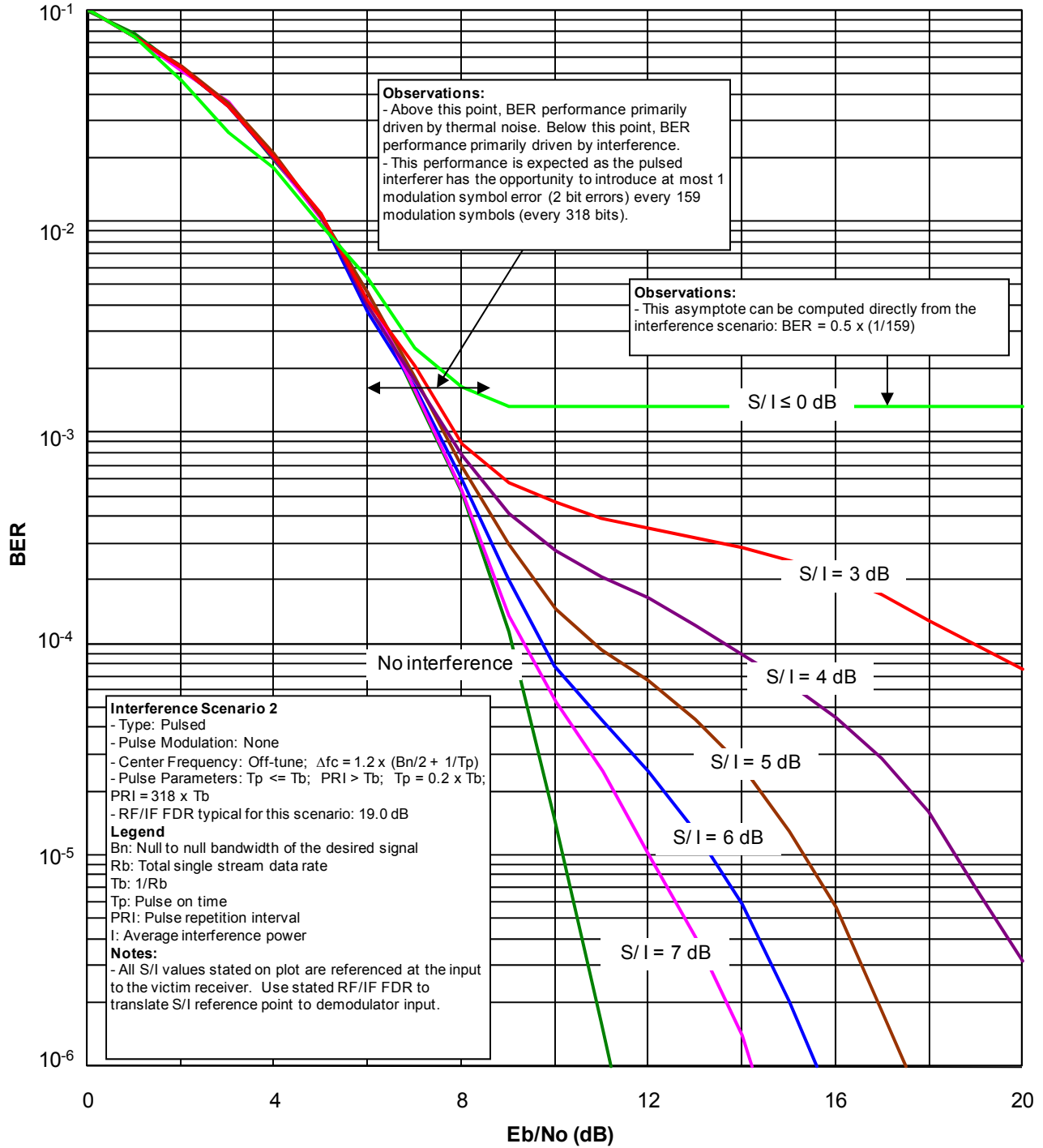

Figure 6.10-5. BER vs. E_b/N_o Curves for QBL-MSK Receiver with Off-Tune Pulsed Interference Scenario 2

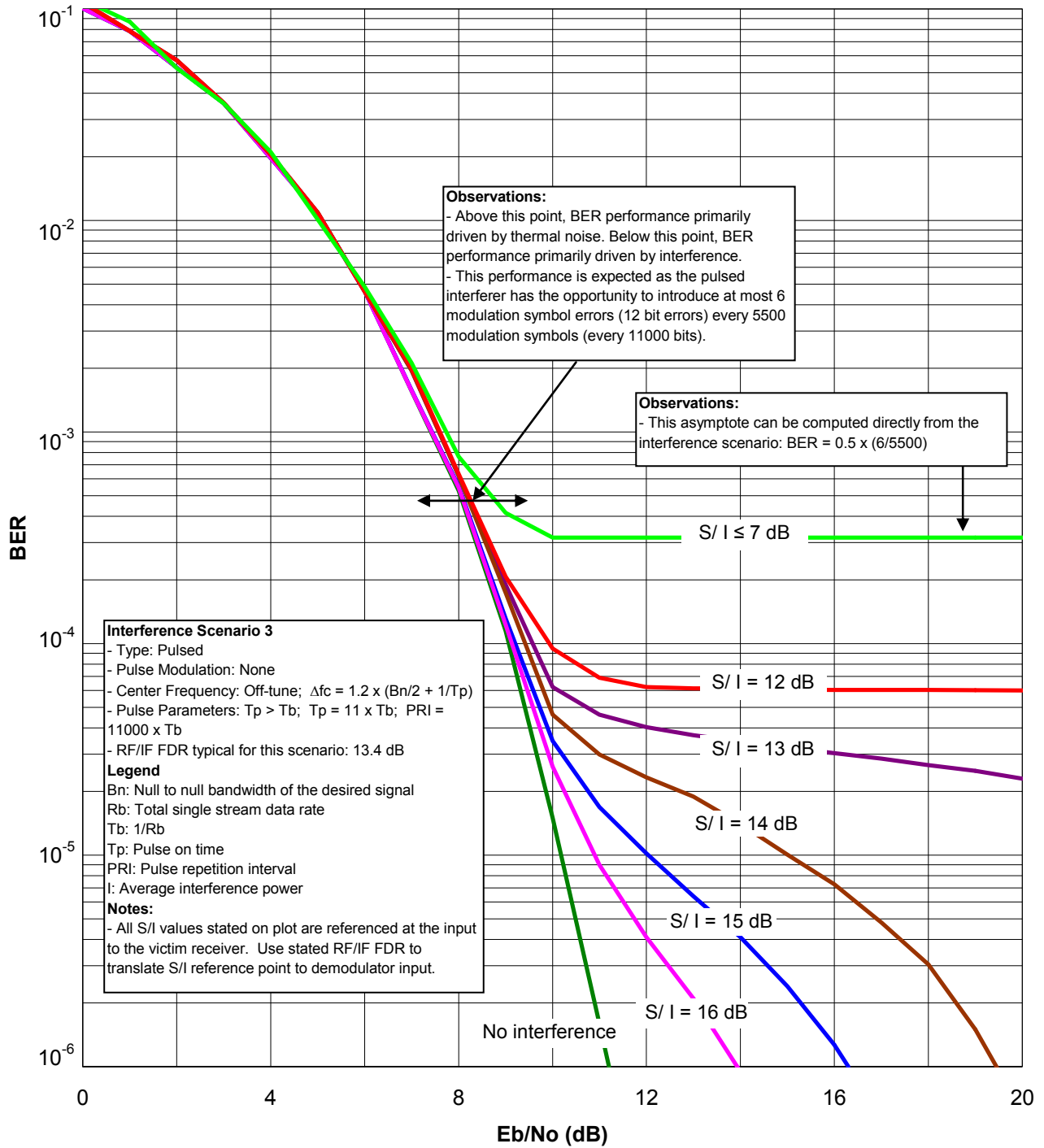

Figure 6.10-6. BER vs. E_b/N_o Curves for QBL-MSK Receiver with Off-Tune Pulsed Interference Scenario 3

6.11 GAUSSIAN MINIMUM-SHIFT KEYING

6.11.1 Description

Pre-modulation Gaussian filtered Minimum-Shift Keying (GMSK) is a variation of MSK. A pre-modulation Gaussian filter has narrow bandwidth and sharp cutoff, which suppresses high frequency components thereby resulting in a bandwidth efficient modulation. GMSK offers good bandwidth efficiency and reasonably good power efficiency, while maintaining the constant envelope property.

The impulse response of a GMSK pre-modulation filter is:

$$h_G(t) = \frac{\sqrt{\pi}}{\alpha} \exp\left(-\frac{\pi^2}{\alpha^2} t^2\right) \quad (6-36)$$

And the transfer function is:

$$H_G(f) = \exp(-\alpha^2 f^2) \quad (6-37)$$

where $\alpha = \frac{\sqrt{\ln 2}}{\sqrt{2B}}$

B is the 3 dB bandwidth of $H_G(f)$

6.11.2 BER Curves

Figure 6-11-1 shows BER curves for a GMSK receiver with on-tune broadband AWGN interference. Figure 6.11-2 shows BER curves for a GMSK receiver with on-tune CW interference.

Figures 6.11-3, 6.11-4, 6.11-5, and 6.11-6 show BER curves for a GMSK receiver with various on-tune pulsed interference scenarios (as annotated on the plots).

Figures 6.11-7 and 6.11-8 show BER curves for a GMSK receiver with various off-tune pulsed interference scenarios (as annotated on the plots).

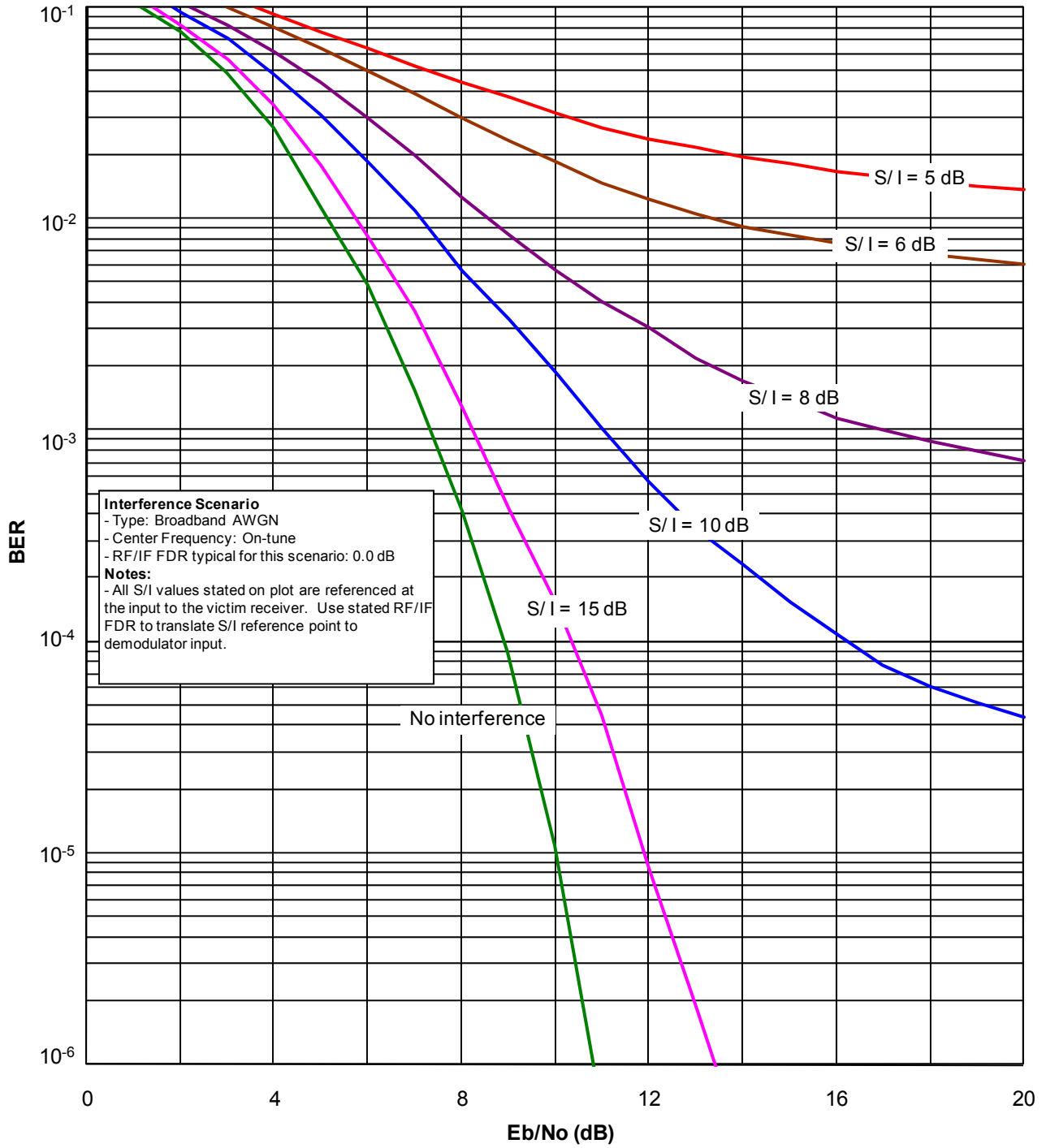

Figure 6.11-1. BER vs. E_b/N_0 Curves for GMSK Receiver with On-Tune Broadband AWGN Interference

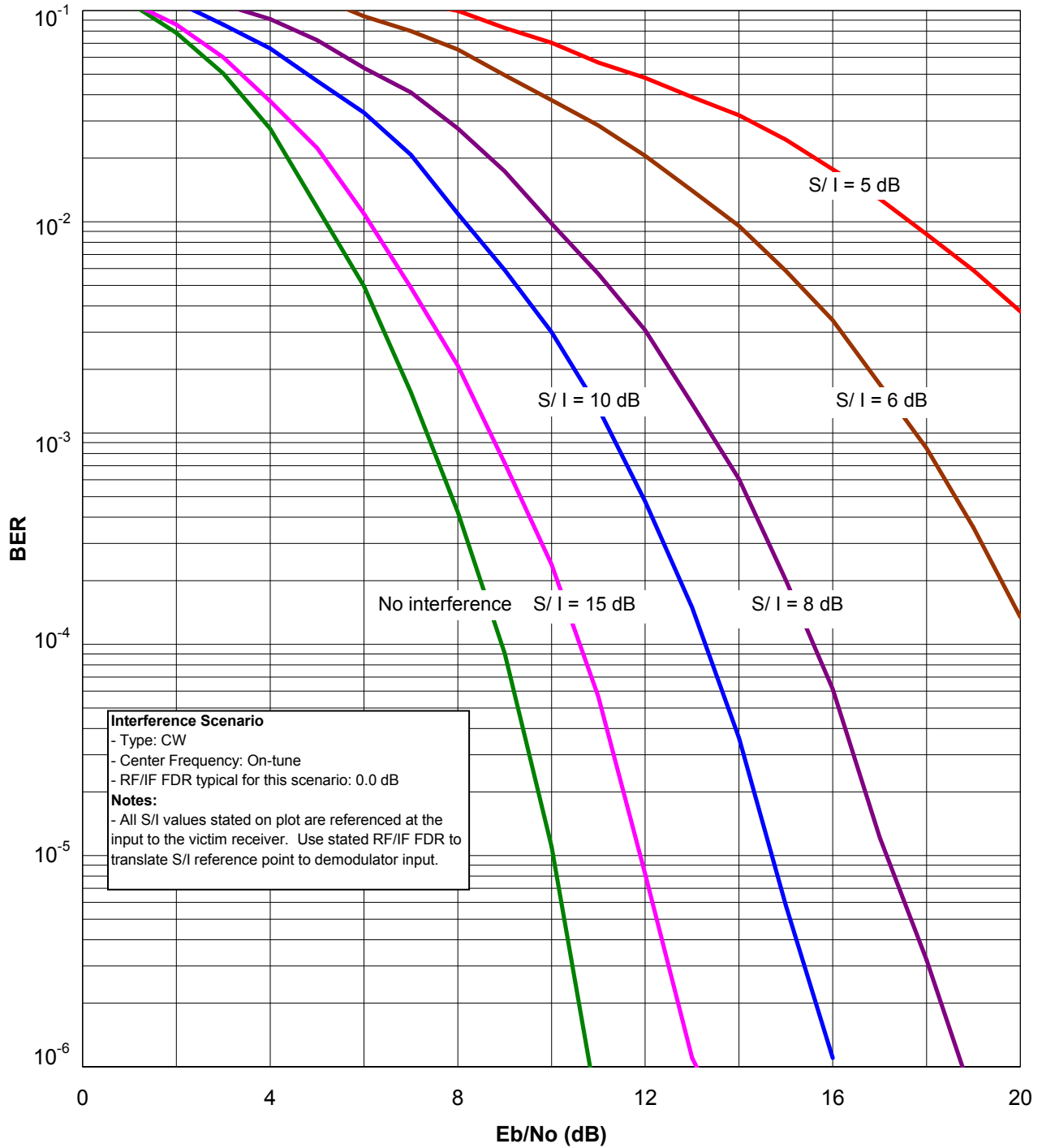

Figure 6.11-2. BER vs. E_b/N_0 Curves for GMSK Receiver with On-Tune CW Interference

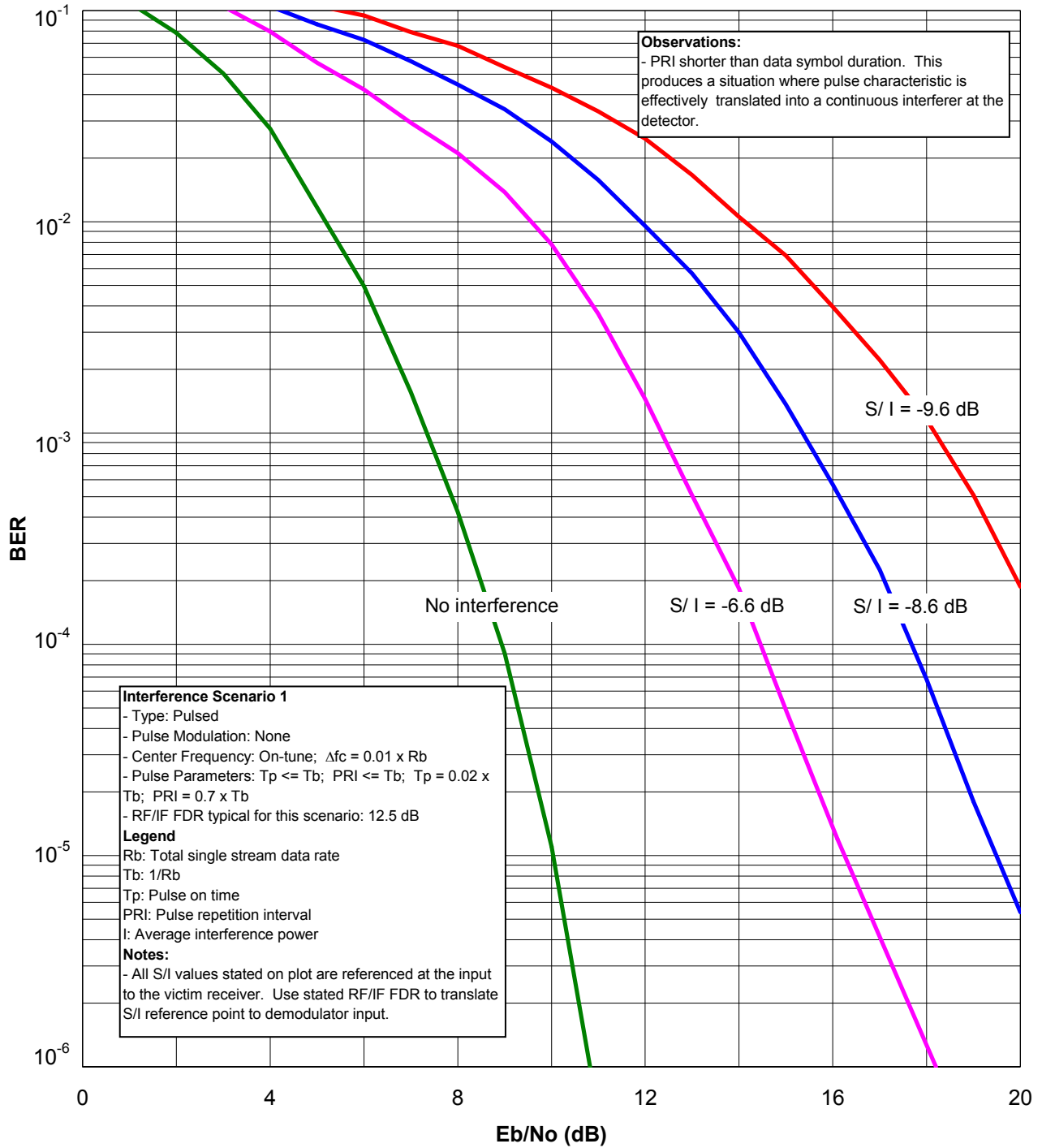

Figure 6.11-3. BER vs. E_b/N_o Curves for GMSK Receiver with On-Tune Pulsed Interference Scenario 1

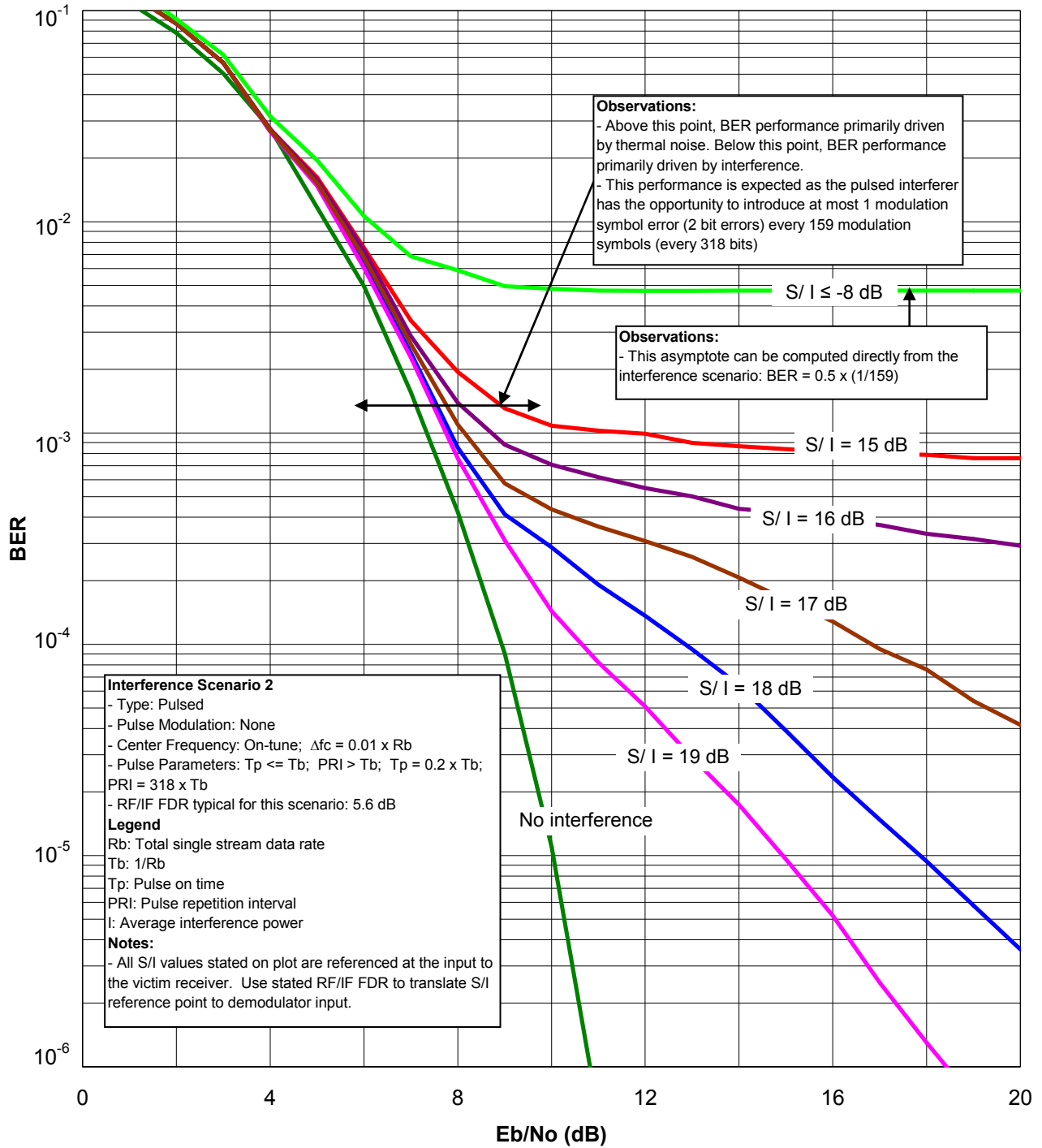

Figure 6.11-4. BER vs. E_b/N_0 Curves for GMSK Receiver with On-Tune Pulsed Interference Scenario 2

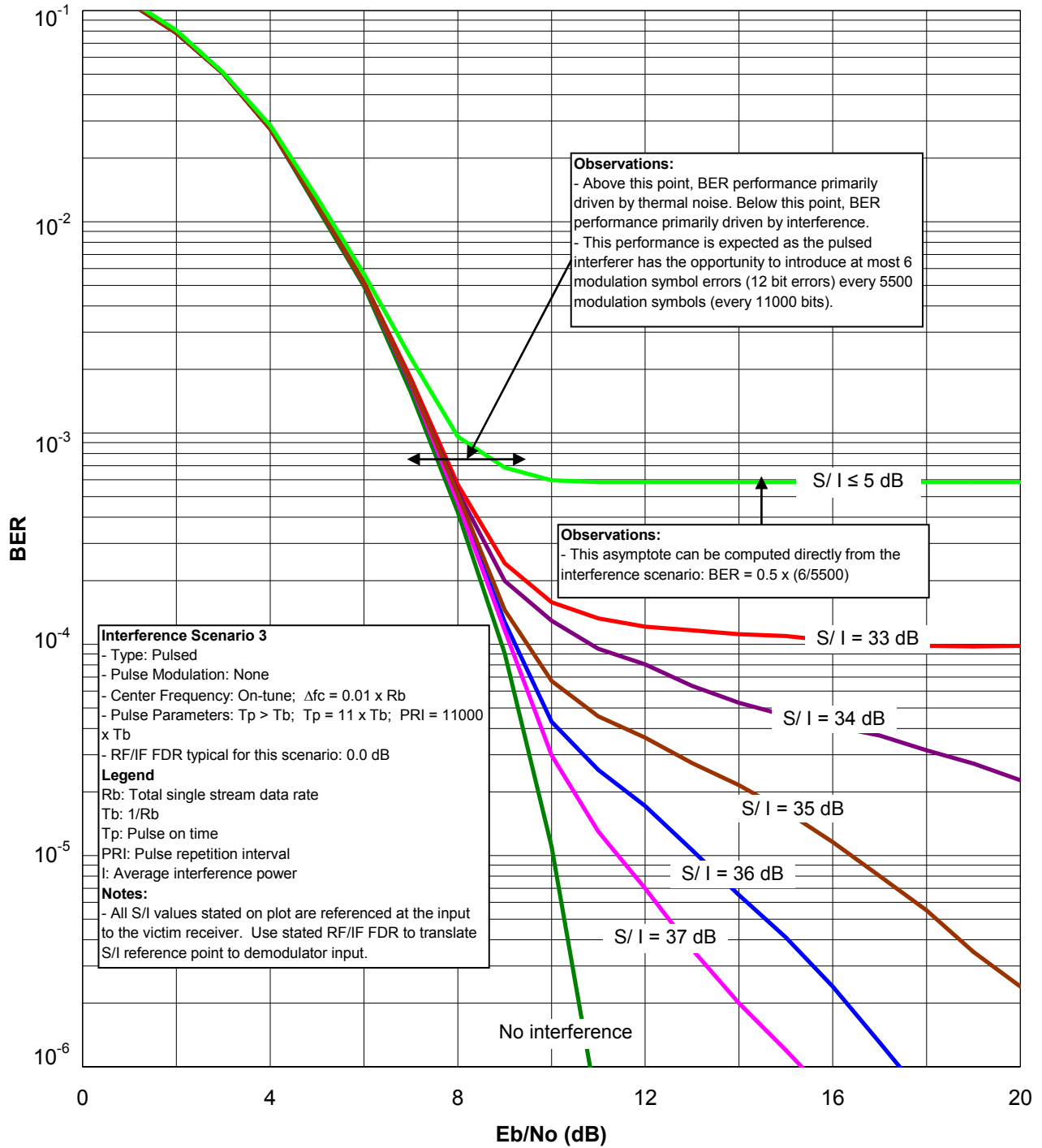

Figure 6.11-5. BER vs. E_b/N_o Curves for GMSK Receiver with On-Tune Pulsed Interference Scenario 3

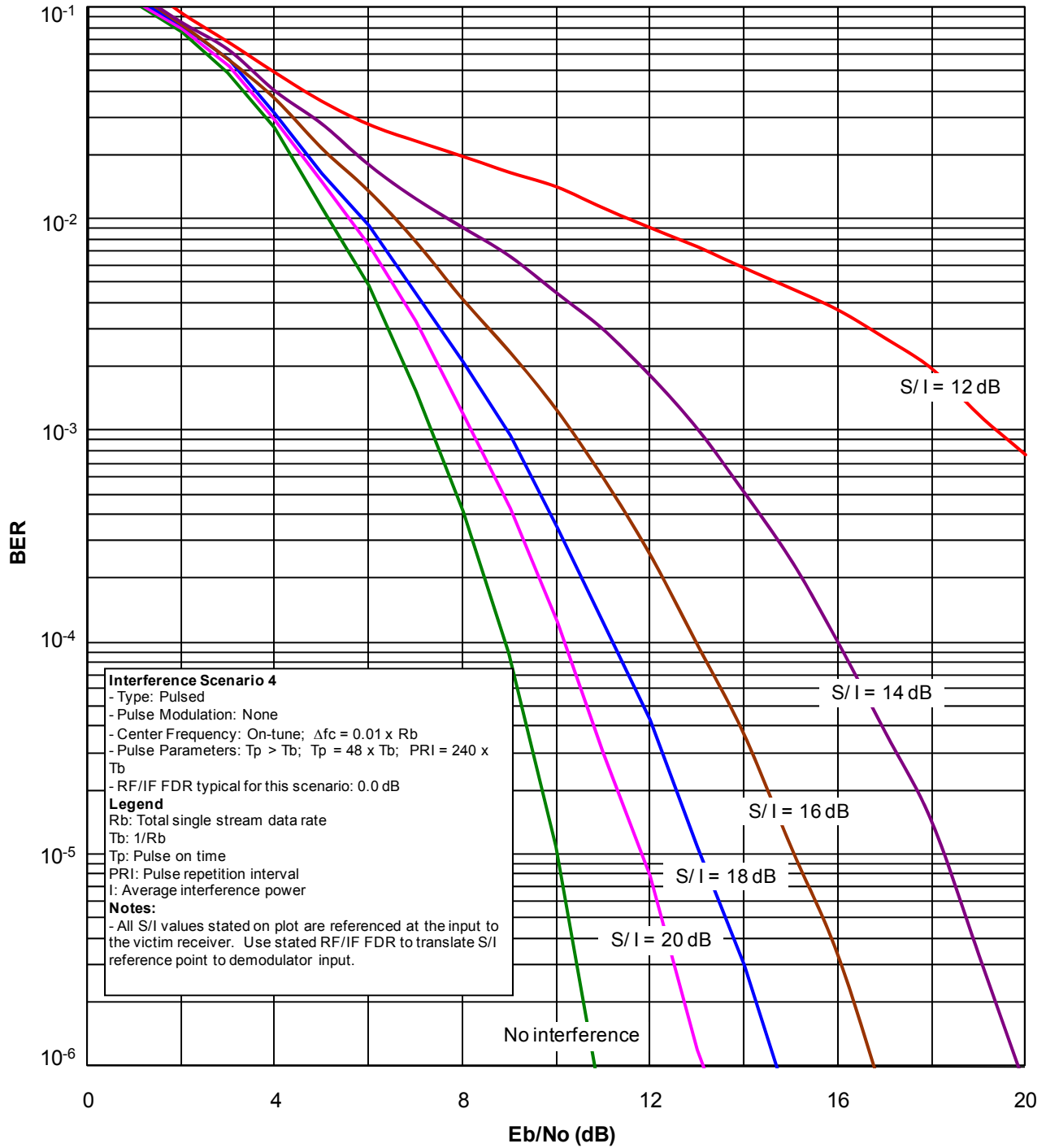

Figure 6.11-6. BER vs. E_b/N_0 Curves for GMSK Receiver with On-Tune Pulsed Interference Scenario 4

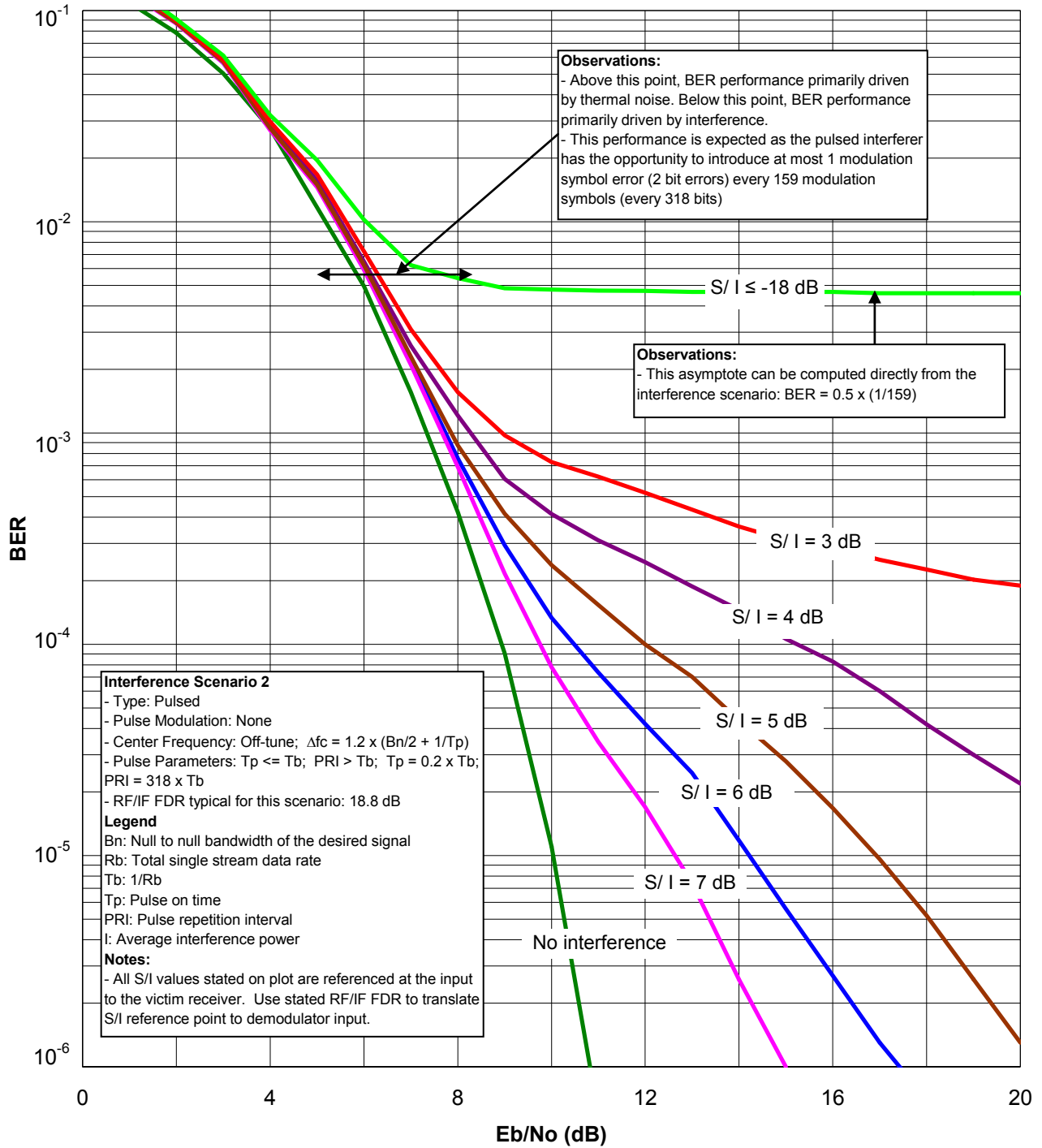

Figure 6.11-7. BER vs. E_b/N_o Curves for GMSK Receiver with Off-Tune Pulsed Interference Scenario 2

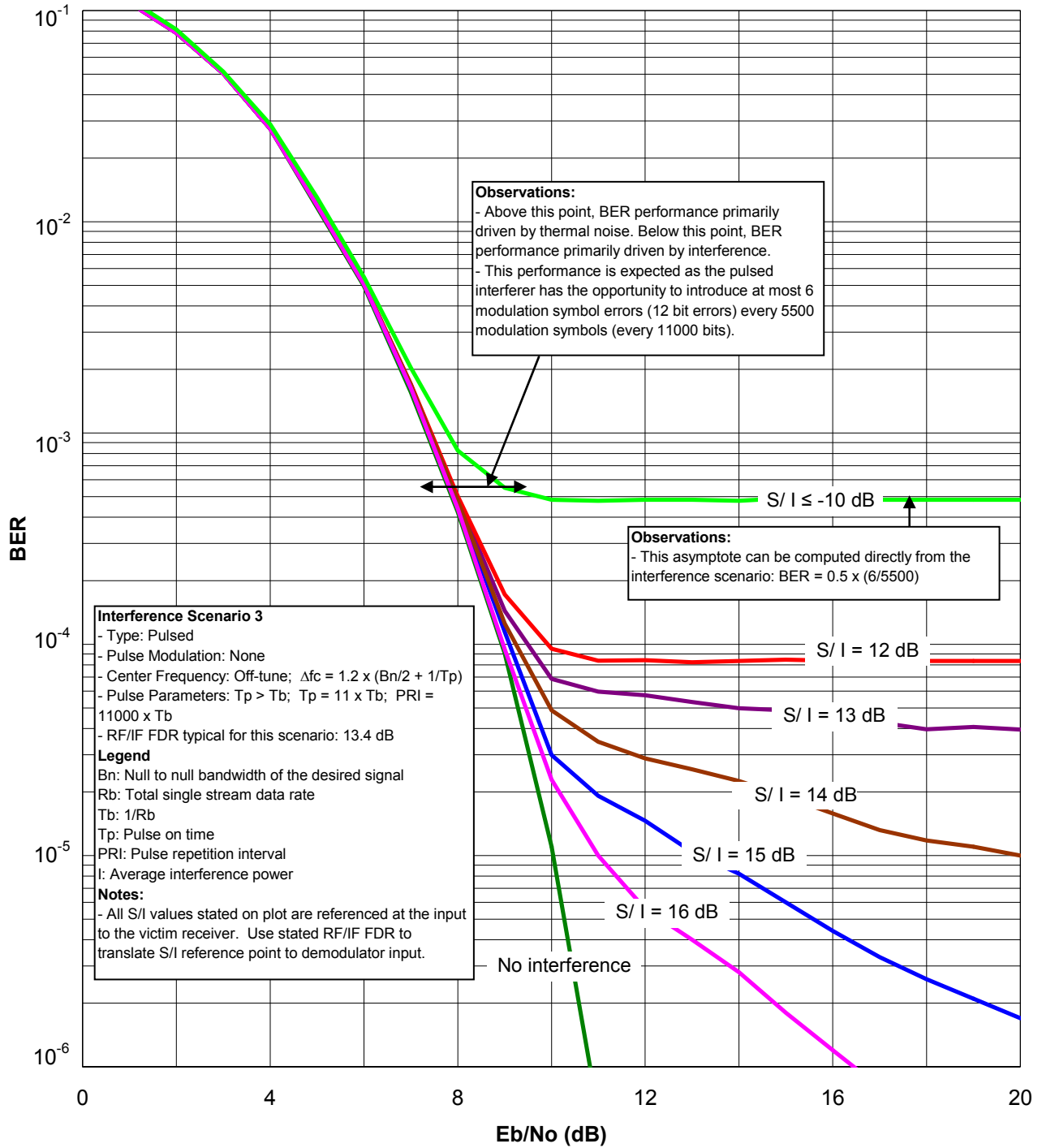

Figure 6.11-8. BER vs. E_b/N_o Curves for GMSK Receiver with Off-Tune Pulsed Interference Scenario 3

6.12 AMPLITUDE-SHIFT KEYING

6.12.1 Description

ASK uses M different equally spaced amplitudes to transmit the digital data. Each M -ary symbol represents k bits of information. The waveform of the ASK signal may be expressed:

$$v_i(t) = A_i u(t) \cos(2\pi ft) \quad (6-38)$$

where A_i is amplitude for symbol i , in V, and $u(t)$ is a pulse-shaping function. If the pulses are rectangular, then $u(t) = 1$. Other pulse shapes may be employed to reduce the required bandwidth of the transmitted signal.

Coherent reception means that the demodulator is phase-locked to the received signal. If the system is coherent, the detector can distinguish phase reversals. In that case, A and $-A$ are two distinct amplitudes. A *unipolar* system uses only non-negative amplitudes, whereas a *bipolar* system uses positive and negative amplitudes. For example, a 4-ary unipolar system has amplitudes $0, a, 2a, 3a$. A 4-ary bipolar system with the same amplitude spacing (a) has amplitudes $-3a/2, -a/2, a/2, 3a/2$.

For noise and noise-like interference, the SER for coherent unipolar M -ary ASK is (reference 8)

$$SER = \frac{M-1}{M} \operatorname{erfc} \left(\sqrt{\frac{3k}{2(M-1)(2M-1)} \frac{E_b}{N_o}} \right) \quad (6-39)$$

For noise and noise-like interference, the SER for coherent bipolar M -ary ASK is⁸

$$SER = \frac{M-1}{M} \operatorname{erfc} \left(\sqrt{\frac{3k}{(M^2-1)} \frac{E_b}{N_o}} \right) \quad (6-40)$$

Thus, it follows from Equation 6-14 for noise and noise-like interference, the BER for coherent unipolar M -ary ASK is

$$BER = \frac{1}{k} \frac{M-1}{M} \operatorname{erfc} \left(\sqrt{\frac{3k}{2(M-1)(2M-1)} \frac{E_b}{N_o}} \right) \quad (6-41)$$

and for noise and noise-like interference, the BER for coherent bipolar M -ary ASK is

$$BER = \frac{1}{k} \frac{M-1}{M} \operatorname{erfc} \left(\sqrt{\frac{3k}{(M^2-1)} \frac{E_b}{N_o}} \right) \quad (6-42)$$

Coherent unipolar binary ASK (with amplitudes 0 and a) is also known as *on-off keying* (OOK). Note that coherent bipolar binary ASK (with amplitudes $-a/2$ and $a/2$) is the same as binary PSK and Equation 6-40 reduces to Equation 6-19 in the binary case. ASK can also be detected noncoherently. In this case, the waveforms must be unipolar. The noncoherent demodulator implementation is simpler, but its performance is not as good as that of coherent detection.

6.12.2 BER Curves

Figures 6.12-1 and 6.12-2 show BER curves for a coherent unipolar ASK receiver with $M = 2$ and $M = 4$, respectively. Figures 6.12-3 and 6.12-4 show BER curves for a coherent bipolar ASK receiver with $M = 4$ and $M = 8$, respectively. Figure 6.12-5 shows BER curves for a noncoherent ASK receiver with no CW interference. In these graphs, the term “interference” and the variable I refer to CW interference. Any noise-like interference power is simply assumed to be added (in mW) to the noise power. For example, suppose there are two interfering signals: a CW signal and a noise-like signal. The S/I parameter is the ratio of the desired signal power to the CW interfering signal power, and the x-axis variable E_b/N_o is calculated with Equation 6-4, where N is the total noise-like power (including the receiver noise and the noise-like interfering signal).

The curves were generated from analytic expressions. The expressions involving CW interference required numerical integration. Figures 6.12-1 through 6.12-4 display six curves of BER vs. E_b/N_o . The curve labeled “No interference” applies to the case in which there is no CW interference. The other five curves are for cases with CW interference. Each of those five curves is labeled with the S/I for that curve. As expected, each curve shows that the BER decreases as the E_b/N_o increases. As also expected, for a given E_b/N_o the BER decreases as the S/I increases.

Figures 6.12-6, 6.12-7, and 6.12-8 show BER curves for an ASK receiver with various on-tune pulsed interference scenarios (as annotated on the plots). Figures 6.12-9 and 6.12-10 show BER curves for an ASK receiver with various off-tune pulsed interference scenarios (as annotated on the plots).

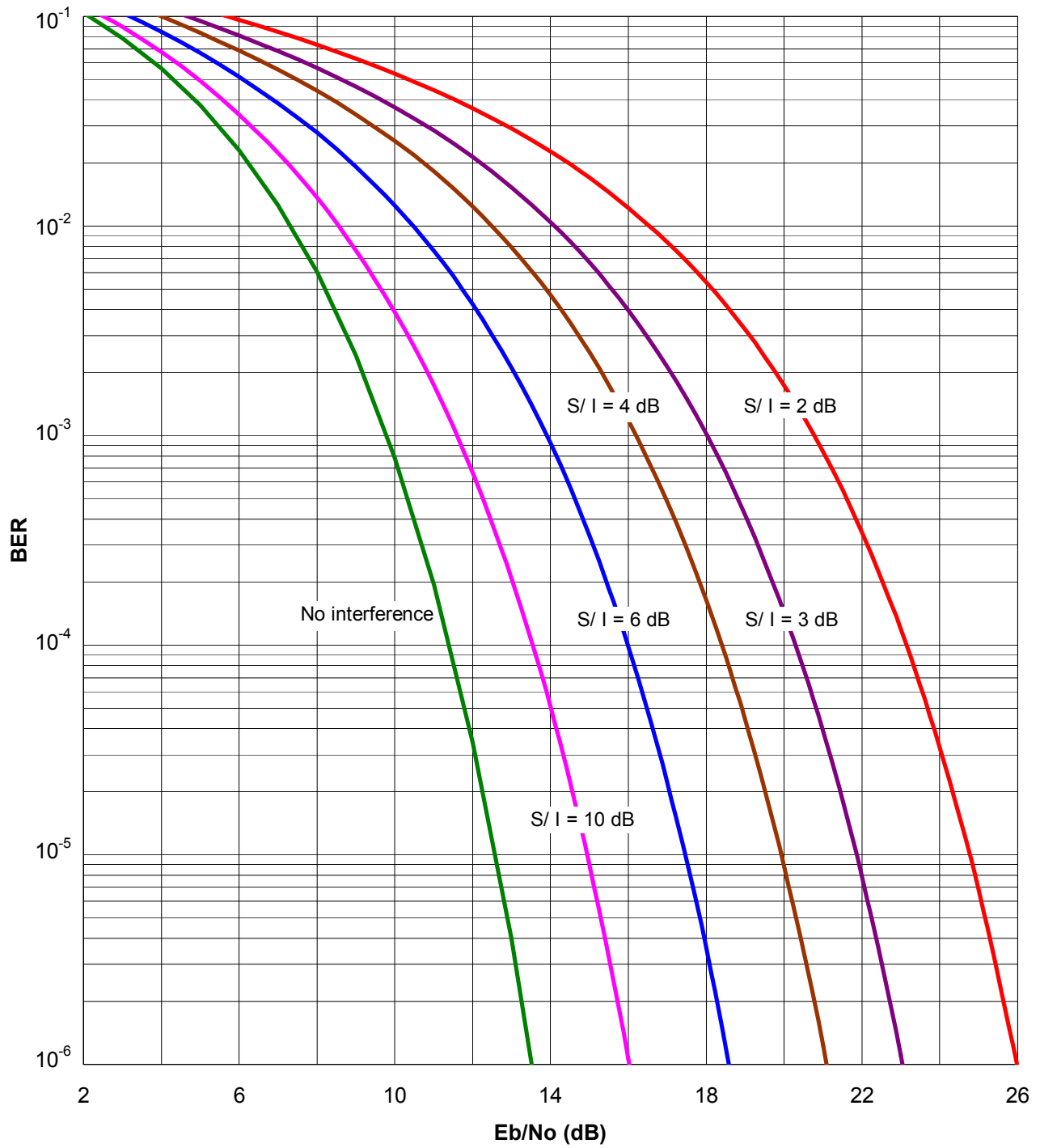

Figure 6.12-1. BER vs. E_b/N_o Curves for Coherent Unipolar ASK Receiver ($M = 2$) with CW Interference

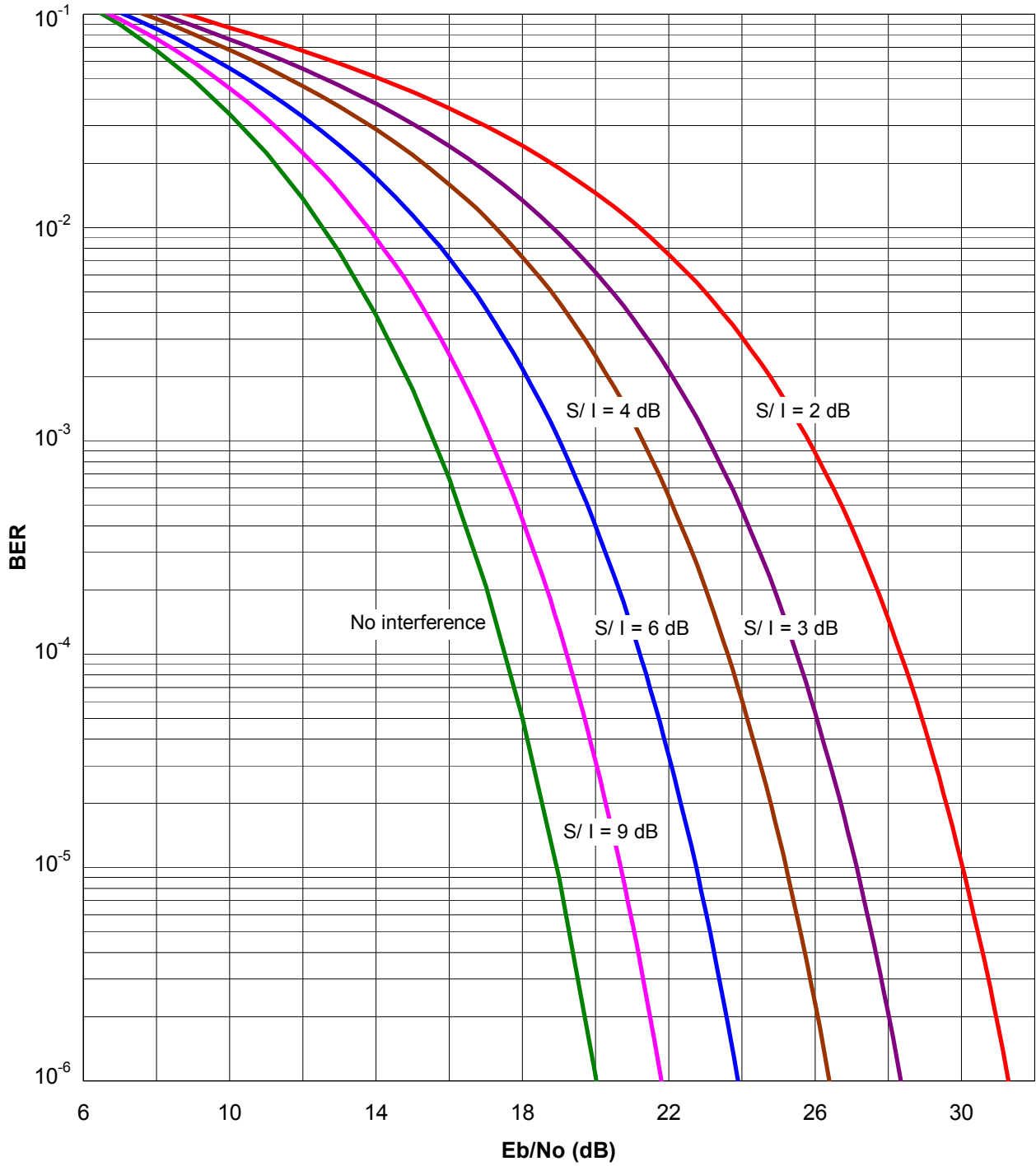

Figure 6.12-2. BER vs. E_b/N_0 Curves for Coherent Unipolar ASK Receiver ($M = 4$) with CW Interference

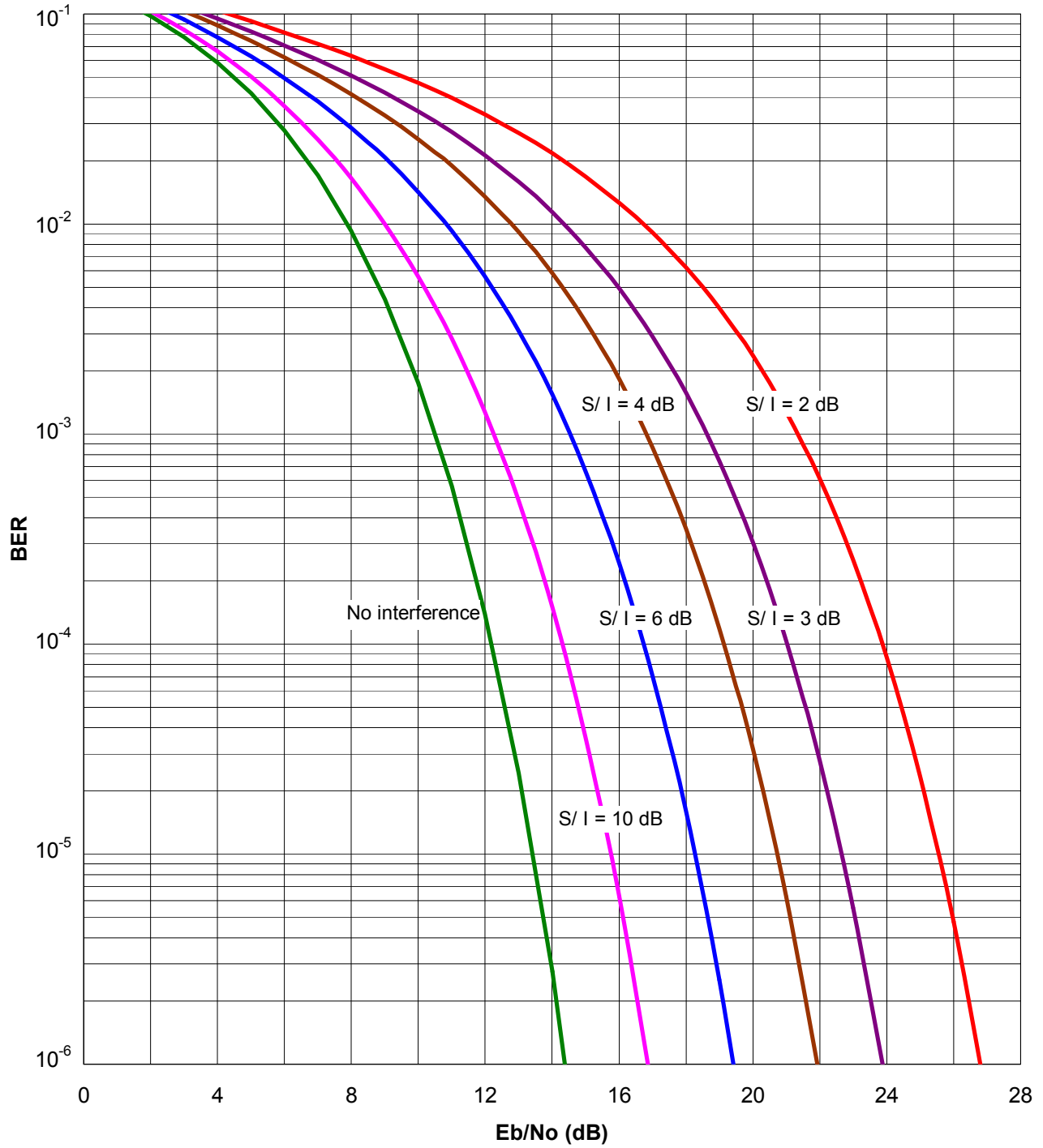

Figure 6.12-3. BER vs. E_b/N_0 Curves for Coherent Bipolar ASK Receiver ($M = 4$) with CW Interference

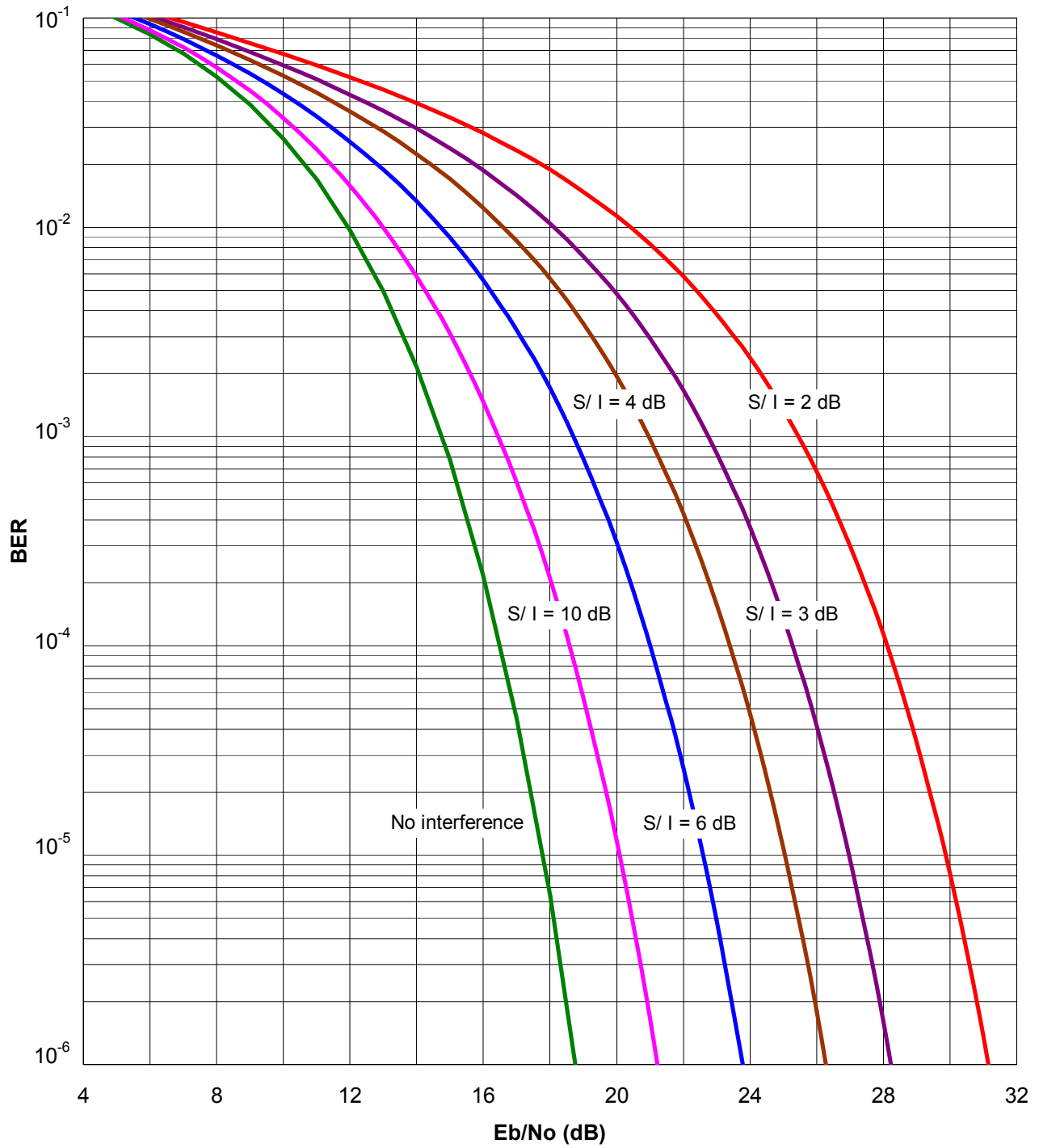

Figure 6.12-4. BER vs. E_b/N_0 Curves for Coherent Bipolar ASK Receiver ($M = 8$) with CW Interference

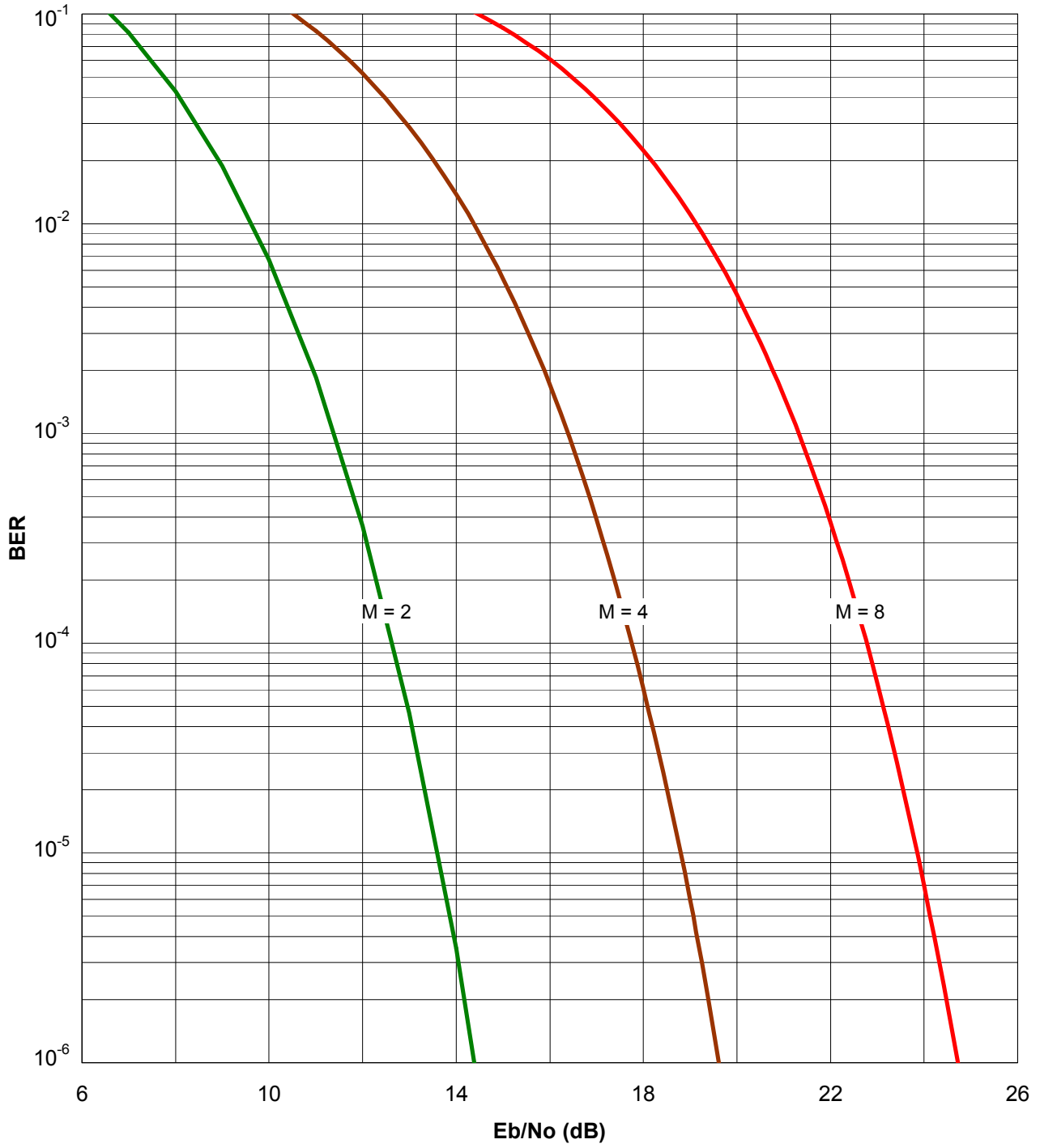

Figure 6.12-5. BER vs. E_b/N_0 Curves for Noncoherent ASK Receiver

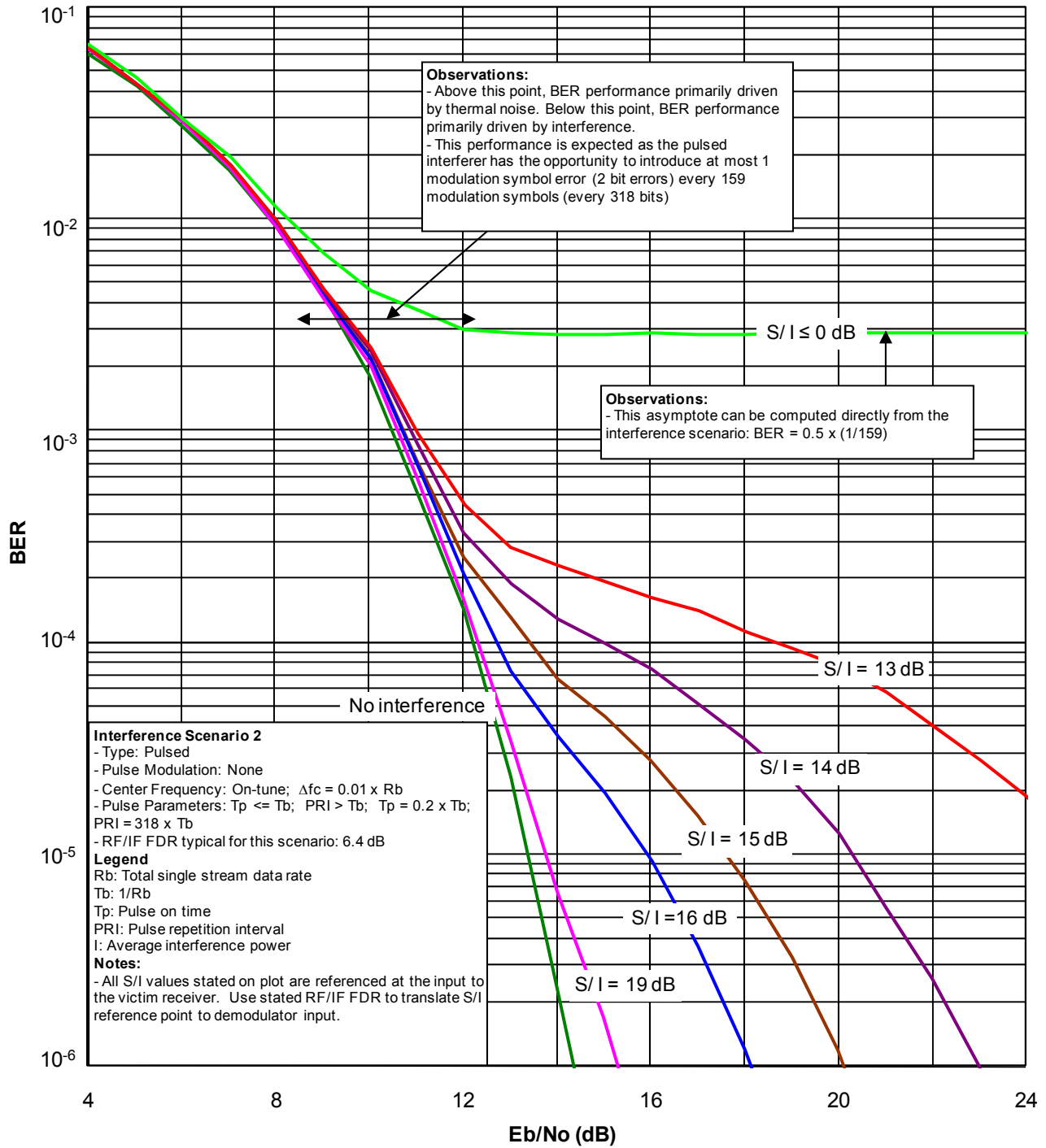

Figure 6.12-6. BER vs. E_b/N_o Curves for ASK Receiver with On-Tune Pulsed Interference Scenario 2

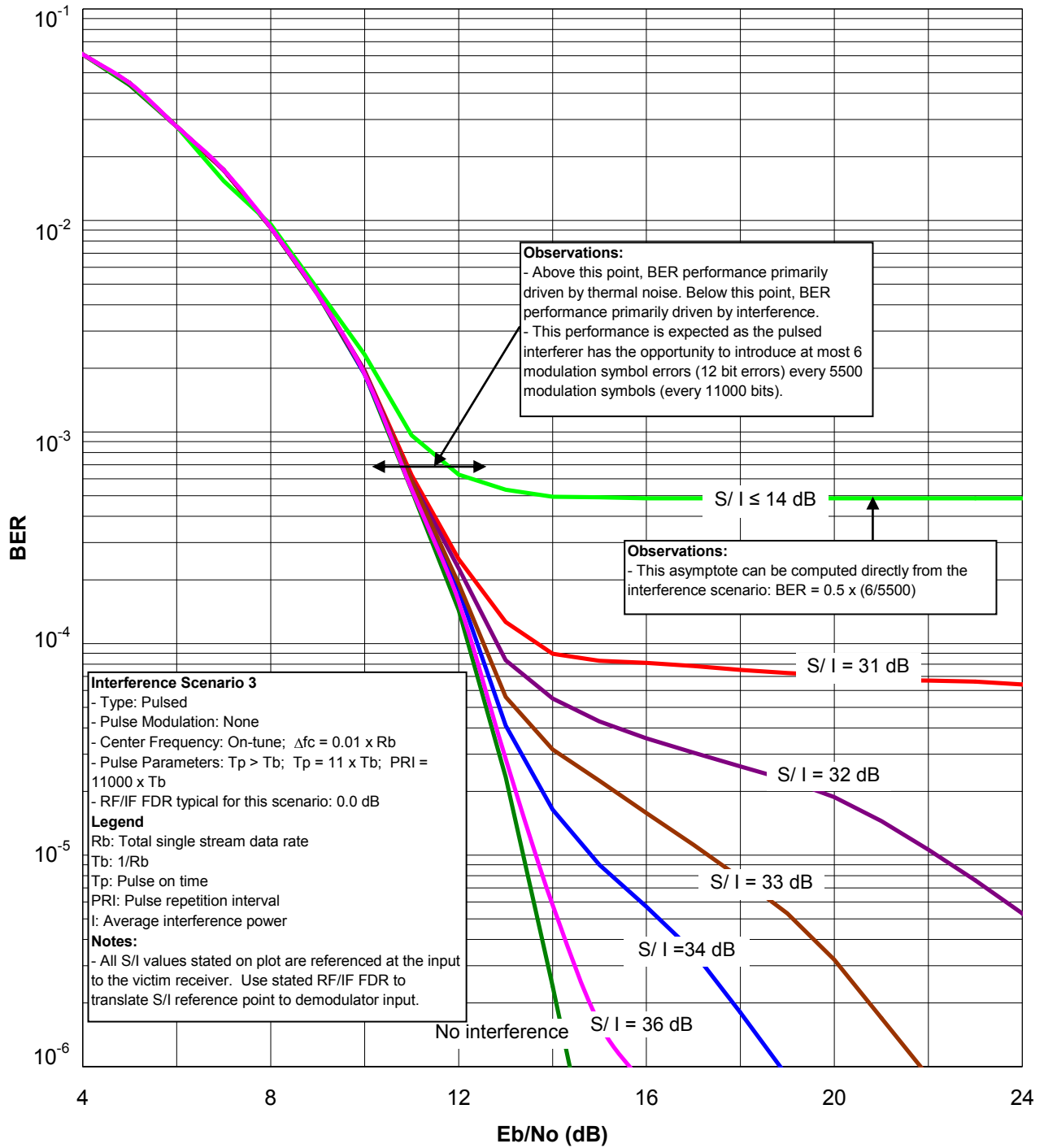

Figure 6.12-7. BER vs. E_b/N_o Curves for ASK Receiver with On-Tune Pulsed Interference Scenario 3

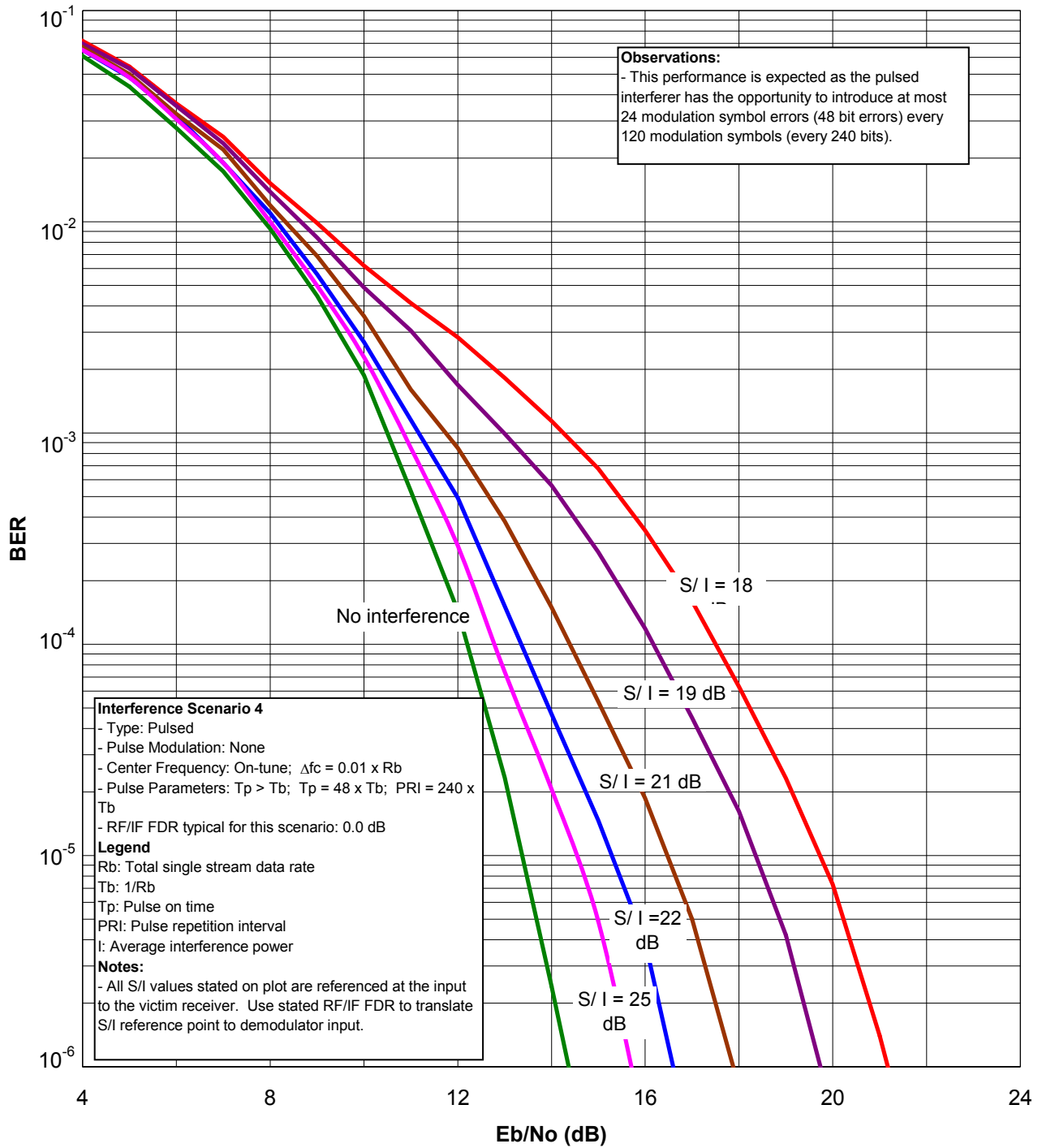

Figure 6.12-8. BER vs. E_b/N_0 Curves for ASK Receiver with On-Tune Pulsed Interference Scenario 4

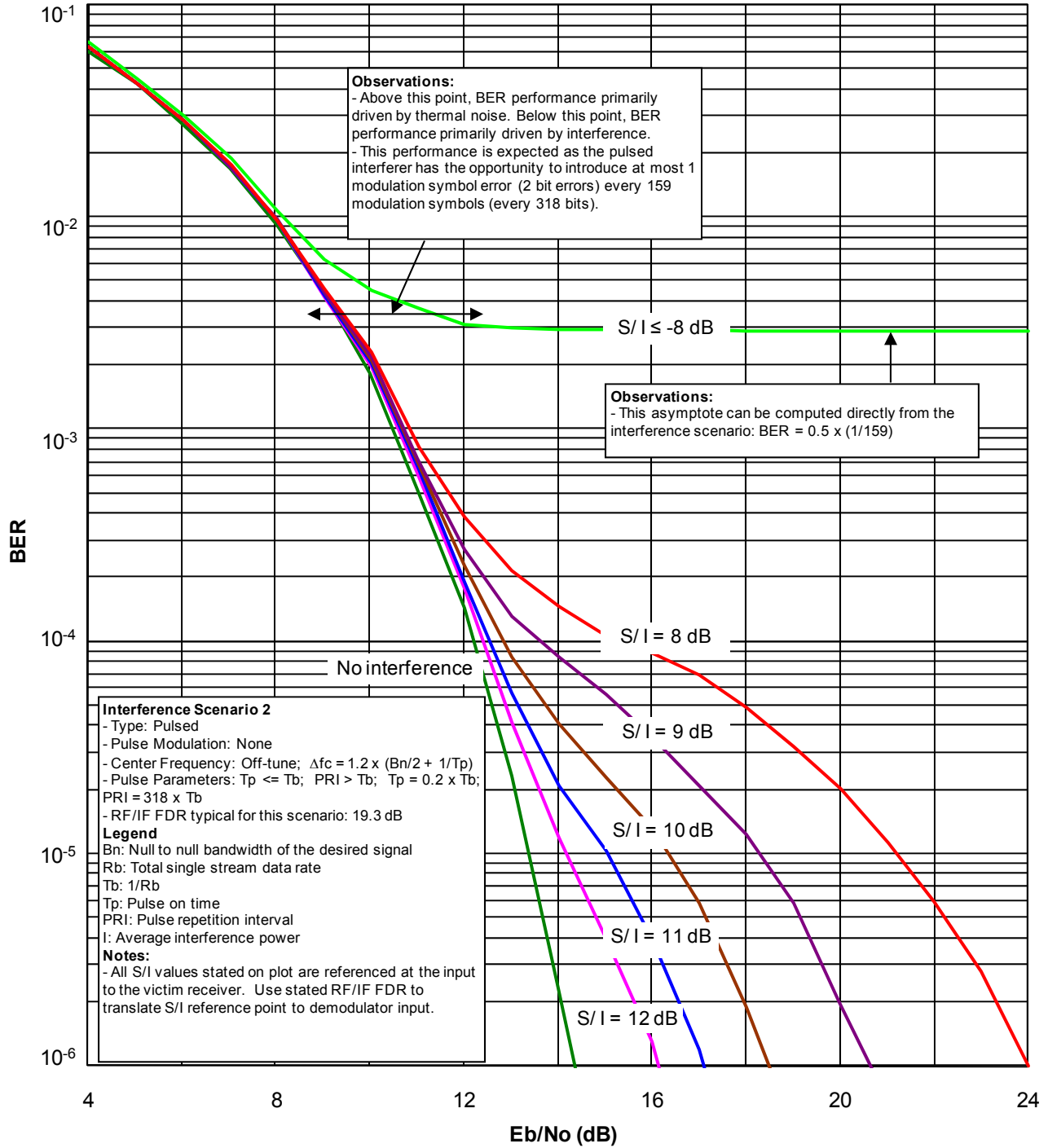

Figure 6.12-9. BER vs. E_b/N_o Curves for ASK Receiver with Off-Tune Pulsed Interference Scenario 2

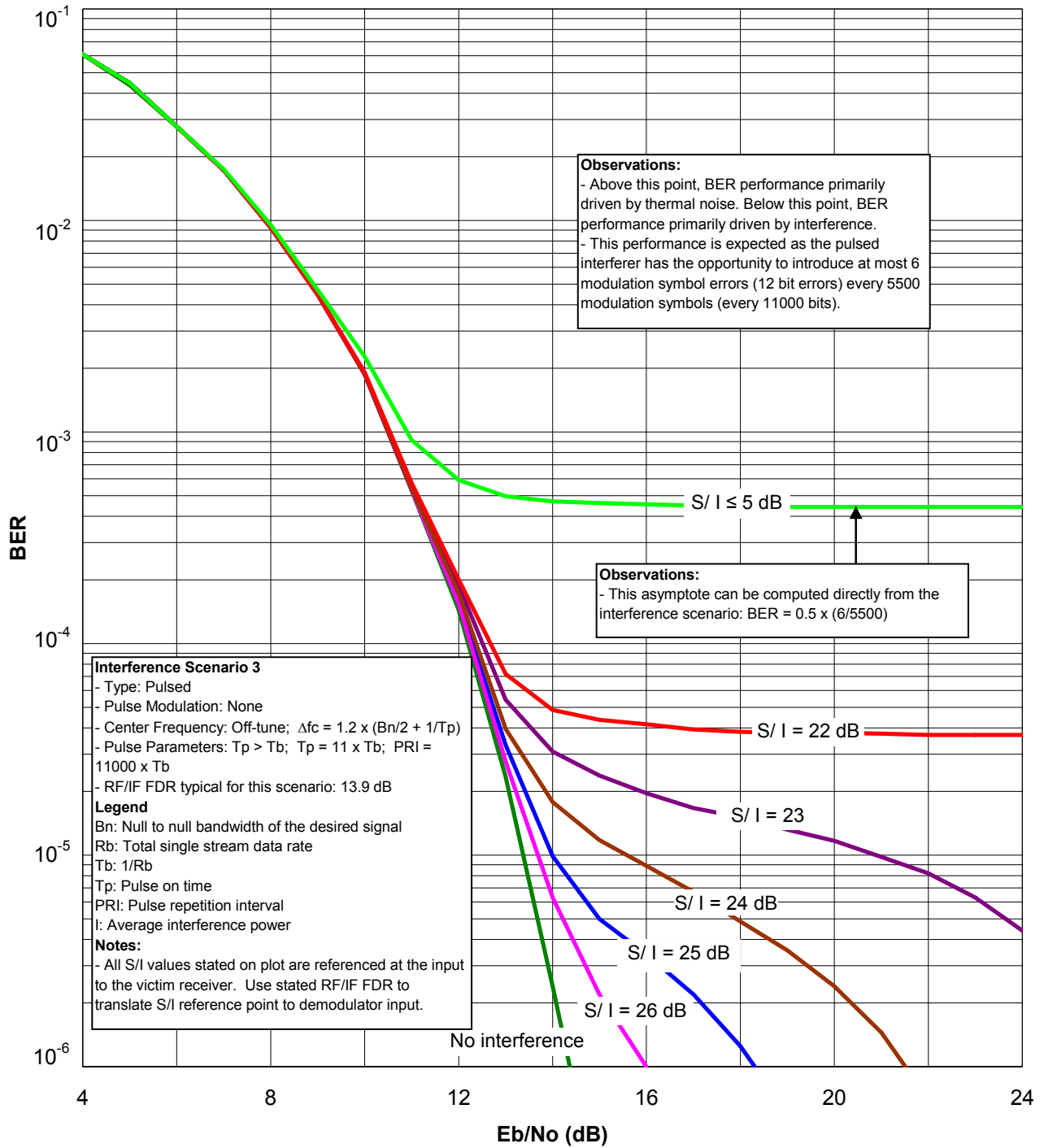

Figure 6.12-10. BER vs. E_b/N_o Curves for ASK Receiver with Off-Tune Pulsed Interference Scenario 3

6.13 QUADRATURE AMPLITUDE-MODULATION

6.13.1 Description

The QAM technique employs two carrier signals in phase quadrature. The QAM-modulated waveform can be expressed:

$$v_i(t) = A_i u(t) \cos(2\pi f_c t) + B_i u(t) \sin(2\pi f_c t) \quad (6-43)$$

where

A_i, B_i = in-phase and quadrature amplitudes for symbol i , in V

$u(t)$ is a pulse-shaping function. If the pulses are rectangular, then $u(t) = 1$. Other pulse shapes may be employed to reduce the required bandwidth of the transmitted signal. Usually, there are 2^m values of A_i and 2^m values of B_i , where m is an integer. Thus, the value of M might be $(2^2)(2^2) = 16$, $(2^3)(2^3) = 64$, $(2^4)(2^4) = 256$, etc. Equation 6-7 ($M = 2^k$) is still applicable, so $M = 256$ when the number of bits per symbol (k) is 16. 4-ary QAM is the same as QPSK.

For noise and noise-like interference, the SER for a QAM system is approximated by:

$$SER = 2 \operatorname{erfc} \left(\sqrt{\frac{3k}{2(M-1)} \frac{E_b}{N_o}} \right) \quad (6-44)$$

QAM can be viewed as two coherent bipolar ASK signals impressed on the quadrature channels. Therefore, the SER with CW interference can be approximately determined by using Equation 6-40 (with $M = \sqrt{M_{\text{QAM}}}$) to determine the SER for each coherent bipolar ASK signal. Then the SER for the QAM signal is given by:

$$SER = 1 - [1 - SER(ASK)]^2 \quad (6-45)$$

where

$SER(ASK)$ = SER from Equation 6-40.

Thus, it follows from Equation 6-14 that for noise and noise-like interference, the BER for a QAM system is approximated by:

$$BER = \frac{2}{k} \operatorname{erfc} \left(\sqrt{\frac{3k}{2(M-1)} \frac{E_b}{N_o}} \right) \quad (6-46)$$

6.13.2 BER Curves

Figures 6.13-1 and 6.13-2 show BER curves for a QAM receiver with $M = 16$ and $M = 64$, respectively. In these graphs, the term “interference” and the variable I refer to CW interference. Any noise-like interference power is simply assumed to be added (in mW) to the noise power. For example, suppose there are two interfering signals: a CW signal and a noise-like signal. The S/I parameter is the ratio of the desired signal power to the CW interfering signal power, and the x-axis variable E_b/N_o is calculated with Equation 6-4, where N is the total noise-like power (including the receiver noise and the noise-like interfering signal).

The curves were generated from analytic expressions. Each figure displays four curves. Each curve is a plot of BER vs. E_b/N_0 . The curve labeled “No interference” applies to the case in which there is no CW interference. The other three curves are for cases with CW interference. Each of those three curves is labeled with the S/I for that curve. As expected, each curve shows that the BER decreases as the E_b/N_0 increases. As also expected, for a given E_b/N_0 the BER decreases as the S/I increases.

Figures 6.13-3, 6.13-4, and 6.13-5 show BER curves for a 16-ary QAM receiver with various on-tune pulsed interference scenarios (as annotated on the plots).

Figures 6.13-6 and 6.13-7 show BER curves for a 16-ary QAM receiver with various off-tune pulsed interference scenarios (as annotated on the plots).

Figure 6.13-8 shows BER curves for a 16-ary QAM receiver with an interferer identical to the victim signal (i.e., two user signals competing for the same frequency).

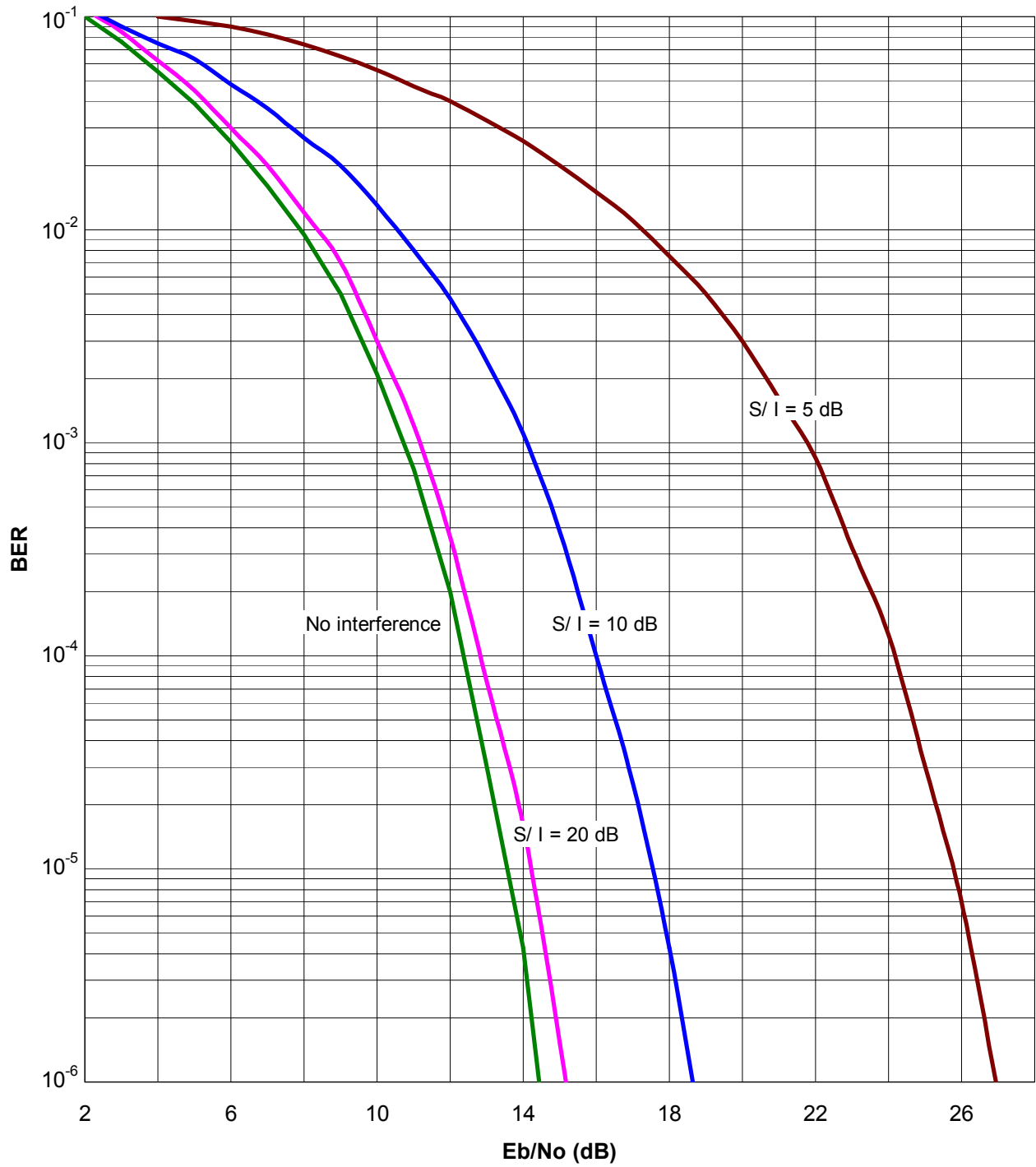

Figure 6.13-1. BER vs. E_b/N_0 Curves for QAM Receiver ($M = 16$) with CW Interference

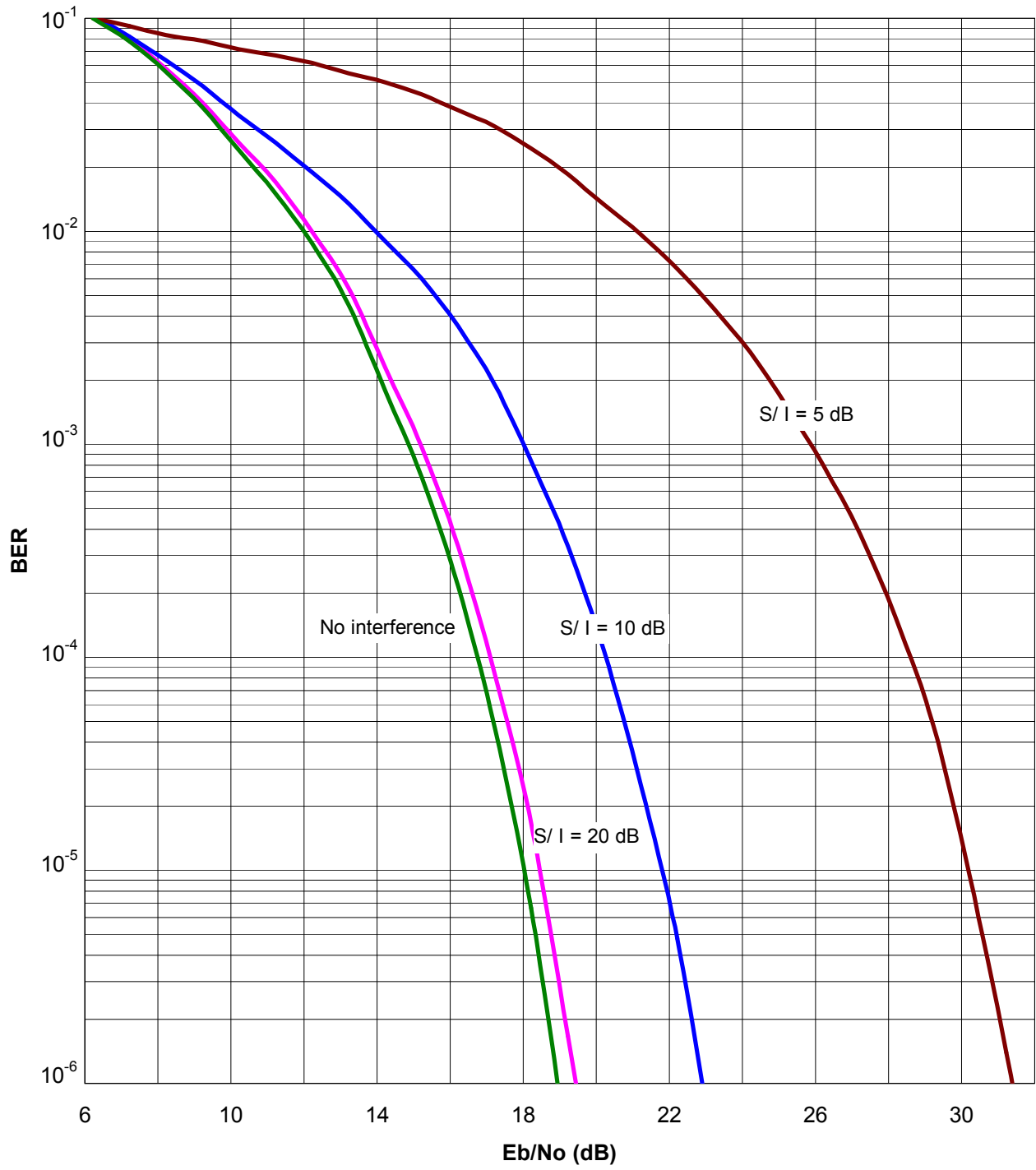

Figure 6.13-2. BER vs. E_b/N_o Curves for QAM Receiver ($M = 64$) with CW Interference

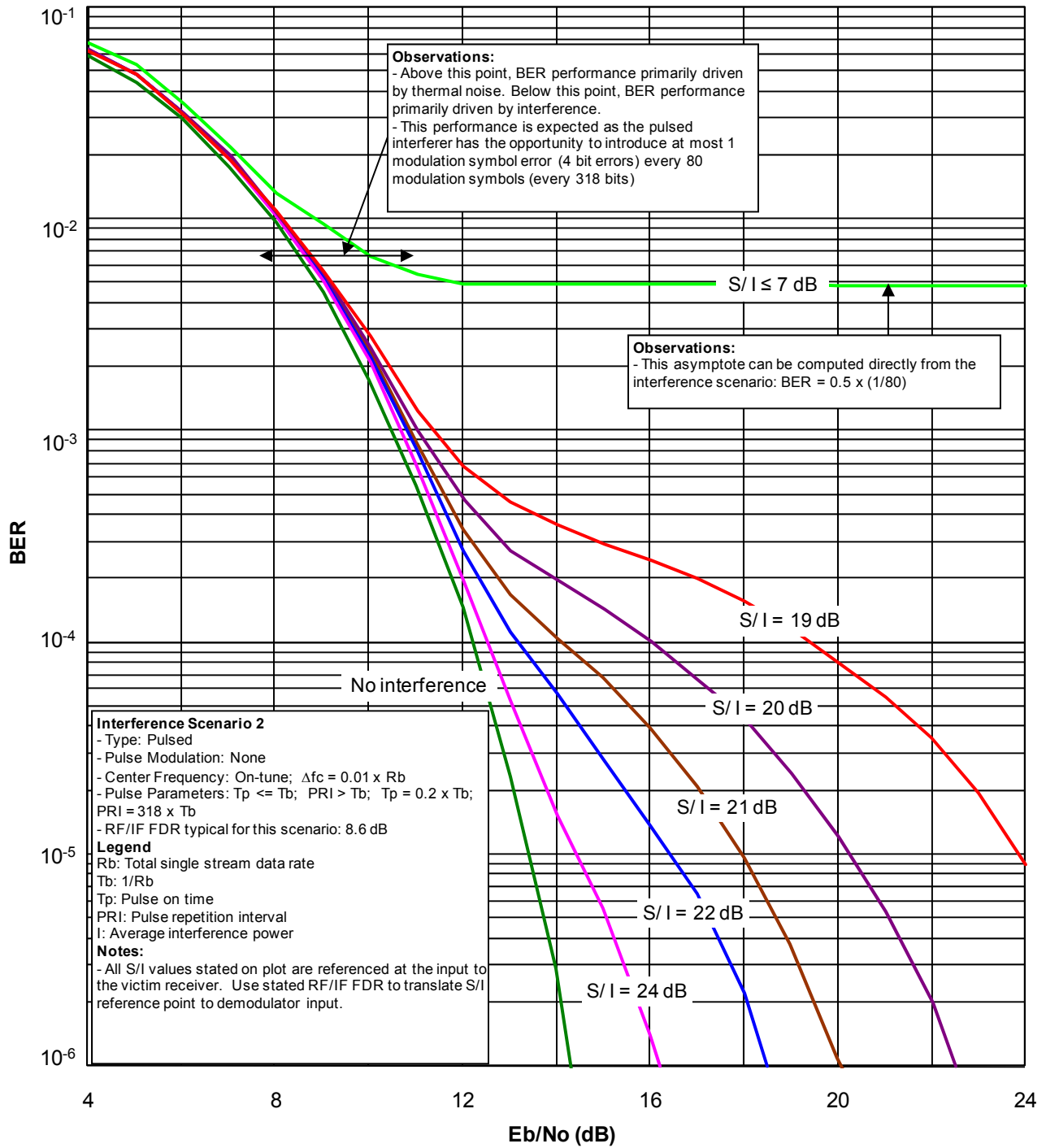

Figure 6.13-3. BER vs. E_b/N_o Curves for QAM Receiver ($M = 16$) with On-Tune Pulsed Interference Scenario 2

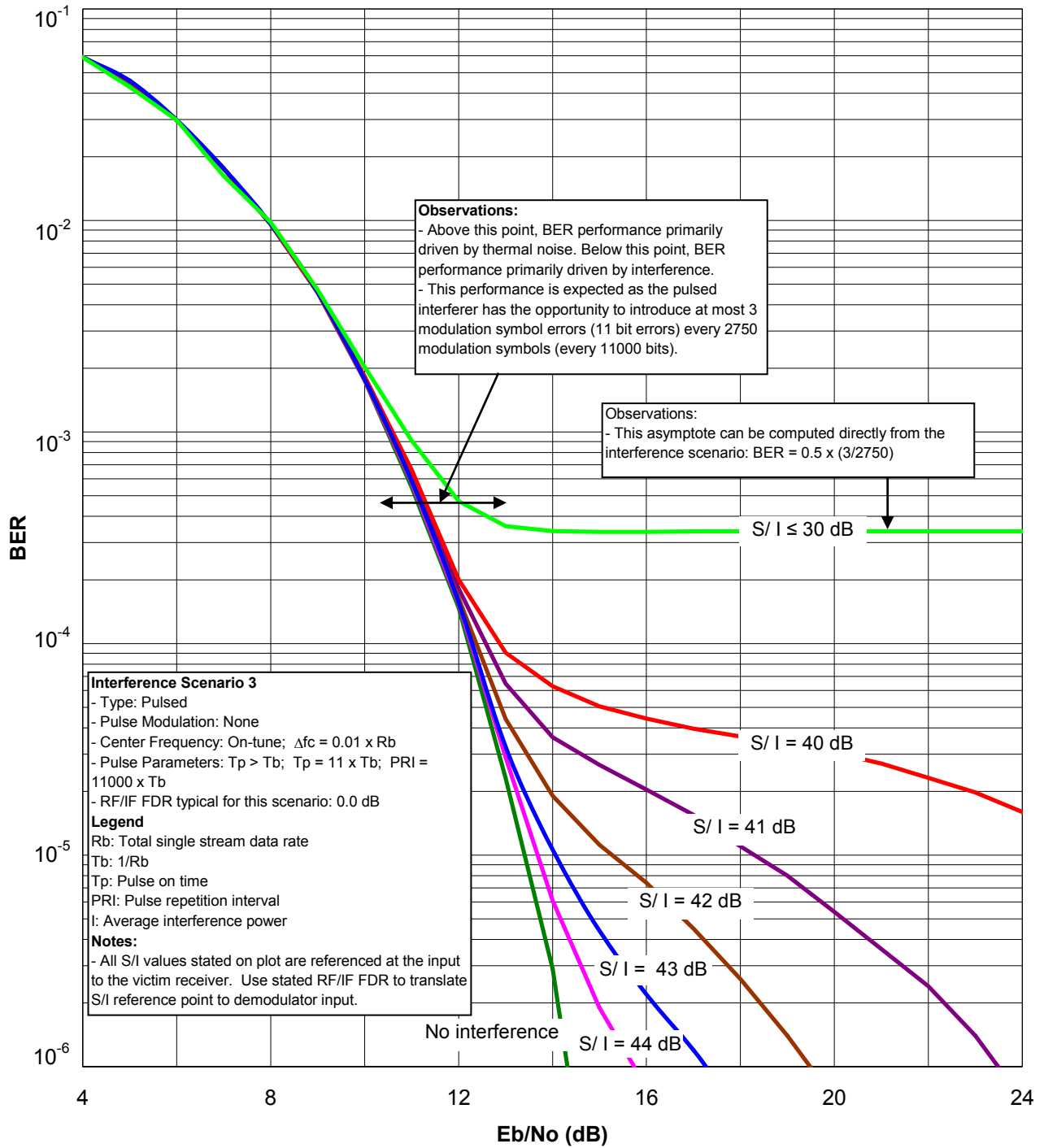

Figure 6.13-4. BER vs. E_b/N_o Curves for QAM Receiver ($M = 16$) with On-Tune Pulsed Interference Scenario 3

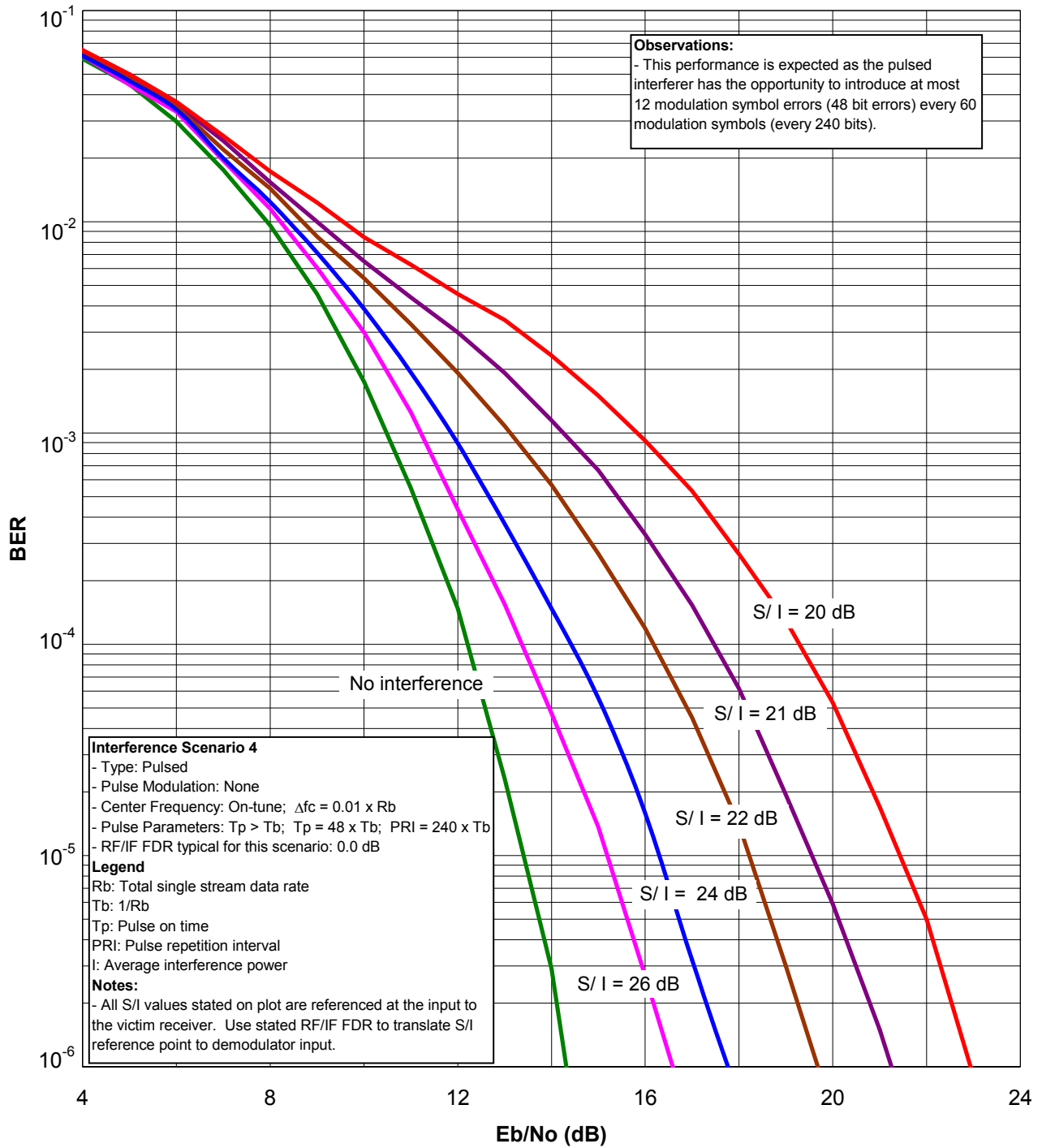

Figure 6.13-5. BER vs. E_b/N_o Curves for QAM Receiver ($M = 16$) with On-Tune Pulsed Interference Scenario 4

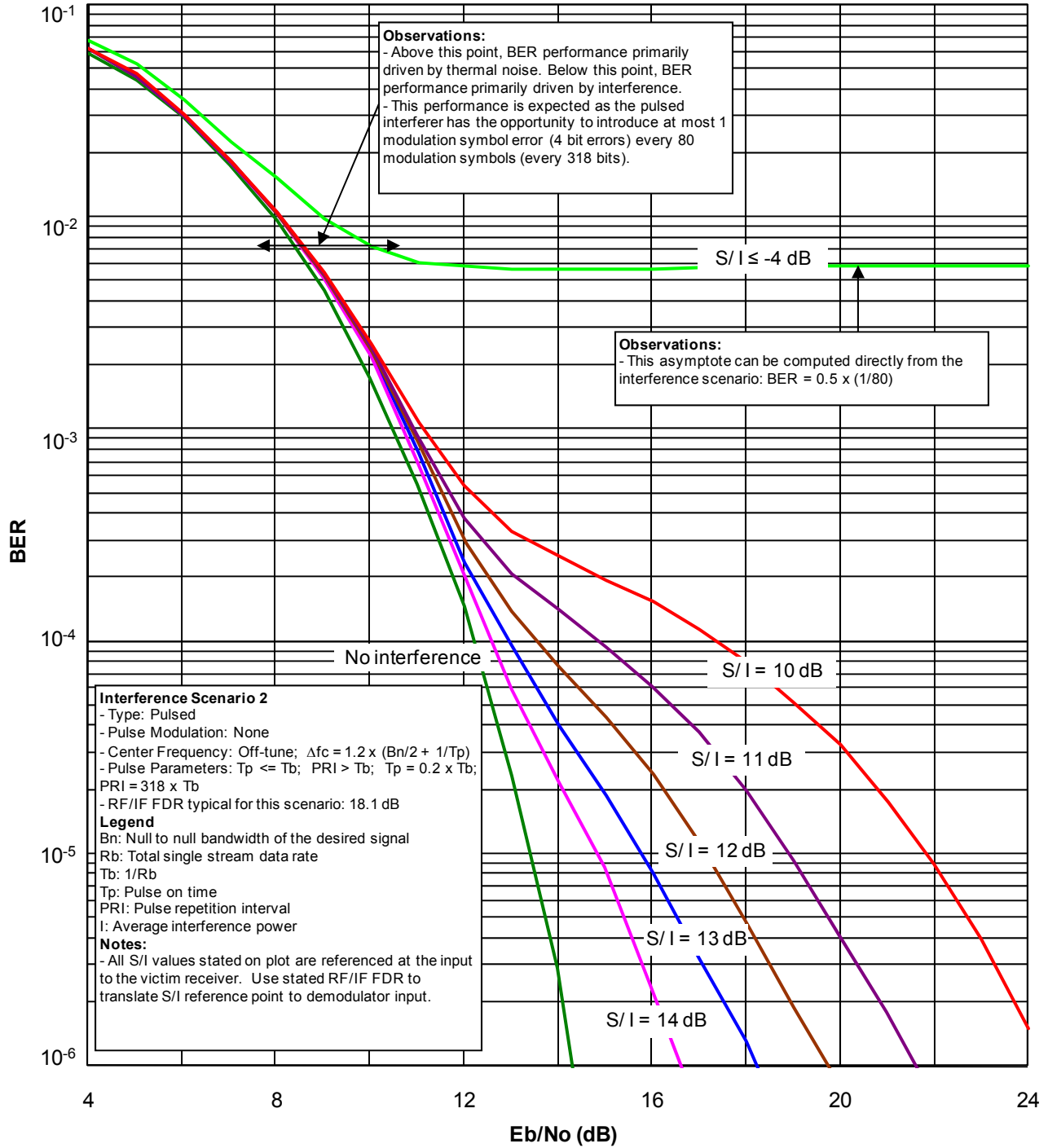

Figure 6.13-6. BER vs. E_b/N_o Curves for QAM Receiver ($M = 16$) with Off-Tune Pulsed Interference Scenario 2

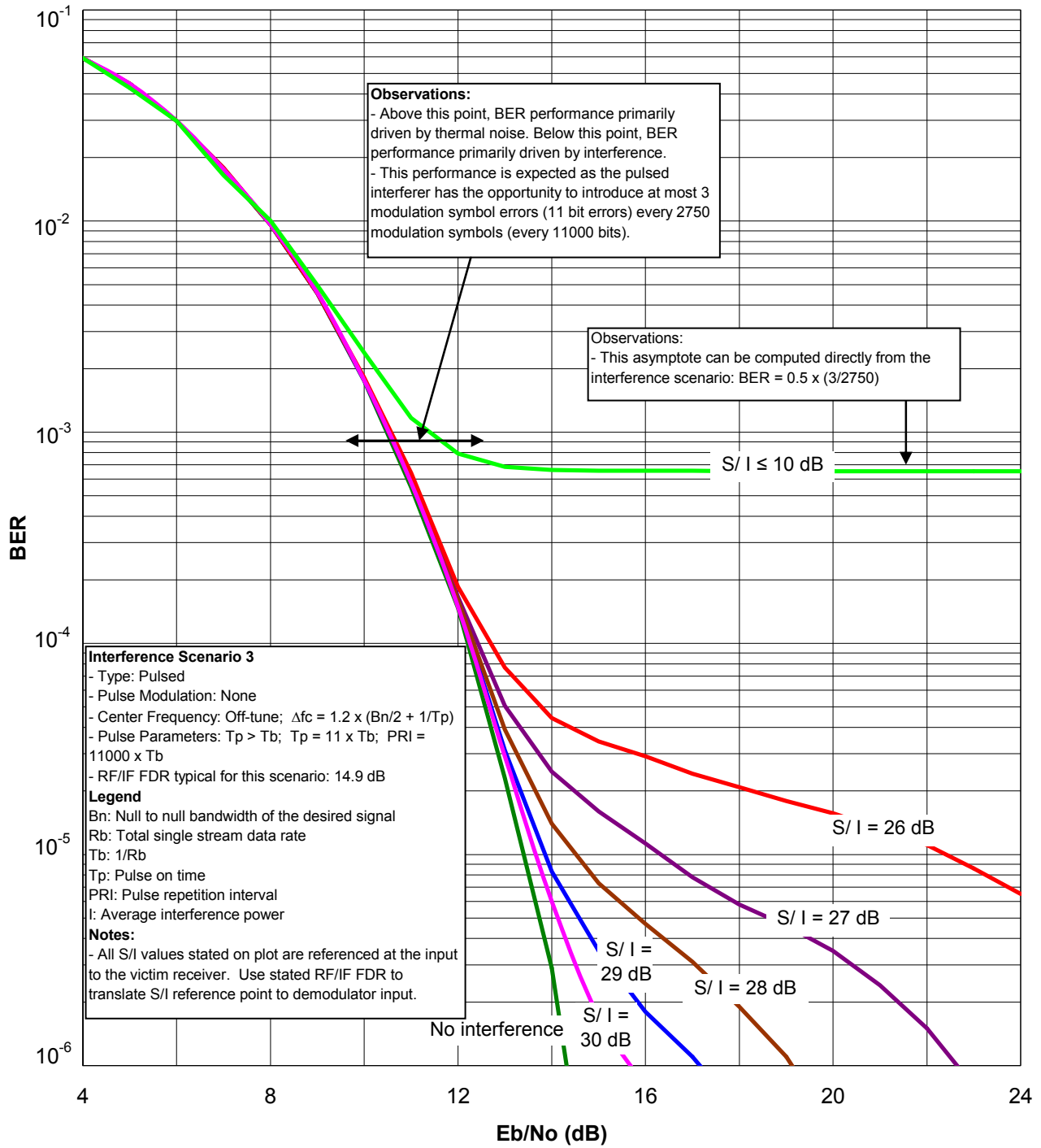

Figure 6.13-7. BER vs. E_b/N_o Curves for QAM Receiver ($M = 16$) with Off-Tune Pulsed Interference Scenario 3

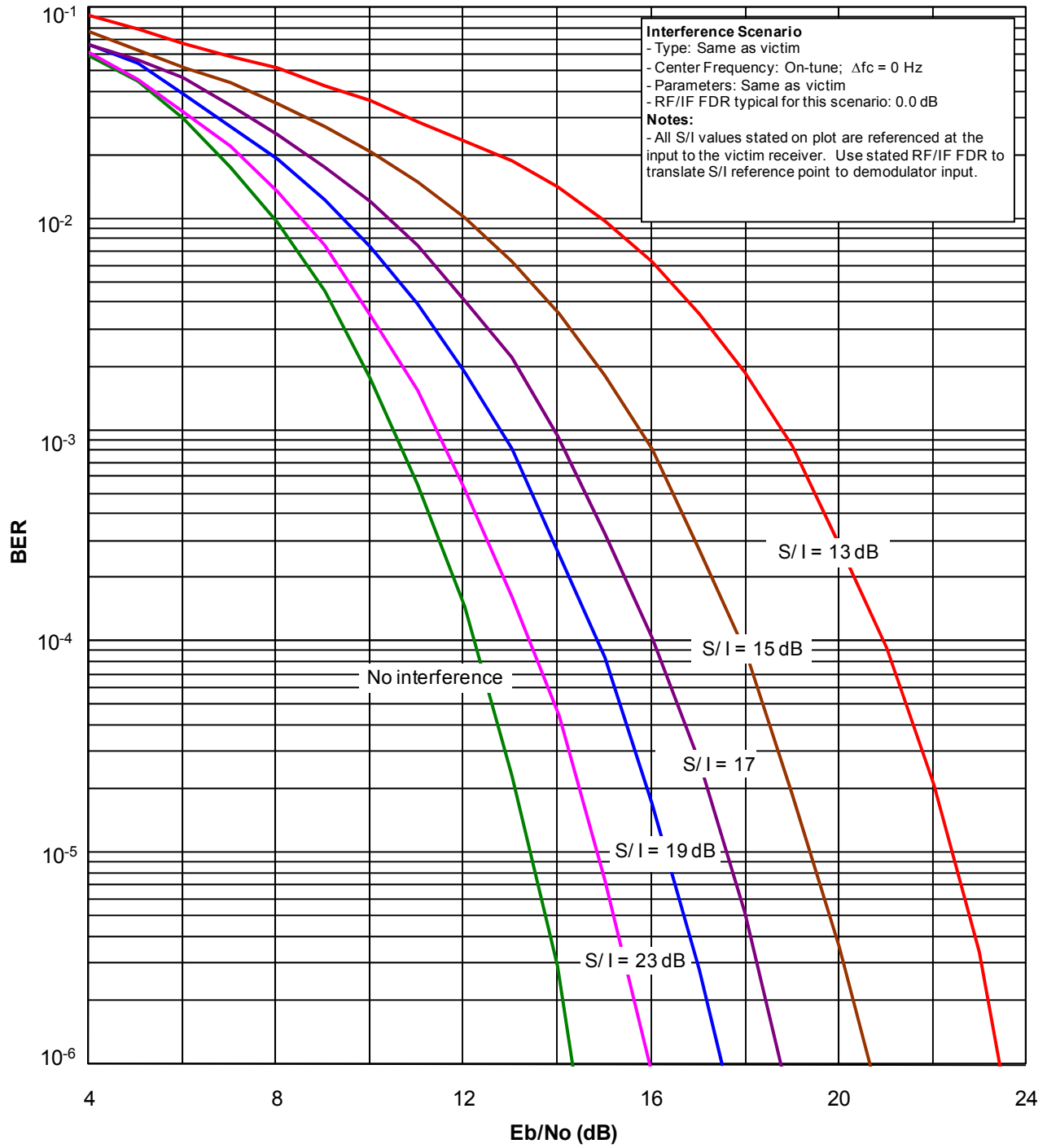

Figure 6.13-8. BER vs. E_b/N_0 Curves for QAM Receiver ($M = 16$) with Same as Victim Interference

6.14 ORTHOGONAL FREQUENCY DIVISION MULTIPLEXING

6.14.1 Description

OFDM is a multicarrier modulation technique currently employed in WiFi and WiMax standards. In OFDM, multiple modulated subcarriers are used over the same transmission path. Each subcarrier operates at frequencies sufficiently spaced apart to ensure orthogonality.

OFDM can be seen as a special case of FDM where the additional orthogonal characteristic ensures that the frequencies do not interfere with neighboring carriers when added together. In FDM systems, signals are moved further apart (guard bands are added) to prevent adjacent signal interference. A high level of spectral efficiency can be achieved since no guard bands are used in OFDM. Other advantages include more immunity to narrowband interference and multipath that cause fading effects.

WiMax and WiFi devices are often deployed in urban environments where multipath channels are common due to obstructions and reflections. OFDM performs well in a frequency selective fading channel (delay spread much larger than symbol period). In such environments, fading will occur at certain frequencies causing data to be substantially corrupted. In OFDM, since only a few (one or two) of the frequency subbands will be affected, frequency selective fading causes less performance degradation than what could be expected on a single carrier modulation system. The total rate being divided among the subcarriers, the symbol rate now becomes lower. This lower information rate makes the system more robust when receiving delayed replicas of the desired signal from reflections. Figure 6.14-1 shows the implementation of an OFDM signal.

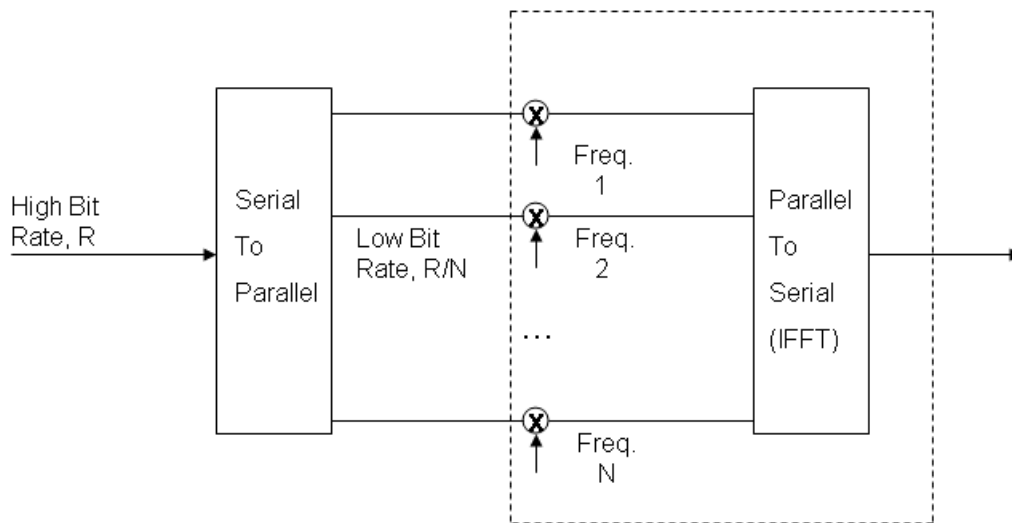

Figure 6.14-1. OFDM Implementation

The baseband OFDM signal is expressed as:

$$S(t) = \sum_{k=0}^{N-1} X_k e^{j2\pi k t / T} \quad 0 \leq t < T \quad (6-47)$$

where

X_k	=	data symbols
N	=	number of sub-carriers
T	=	OFDM symbol time

In practice, the Inverse Fast Fourier Transform (IFFT) is used to create the time-domain OFDM signal. Since OFDM also has the unique characteristic of interfering with itself, a cyclic prefix is added to the OFDM symbol to prevent intrasymbol interference. A cyclic prefix consists of copying the tail end of the symbol and appending it at the start of the symbol.

6.14.2 BER Curves

Figure 6-14-2 shows BER curves for an OFDM receiver with on-tune broadband AWGN interference. Figure 6.14-3 shows BER curves for an OFDM receiver with on-tune CW interference.

Figures 6.14-4, 6.14-5, and 6.14-6 show BER curves for an OFDM receiver with various on-tune pulsed interference scenarios (as annotated on the plots).

Figures 6.14-7 and 6.14-8 show BER curves for an OFDM receiver with various off-tune pulsed interference scenarios (as annotated on the plots).

Figure 6.14-9 shows BER curves for an OFDM receiver with an interferer identical to the victim signal (i.e., two user signals competing for the same frequency).

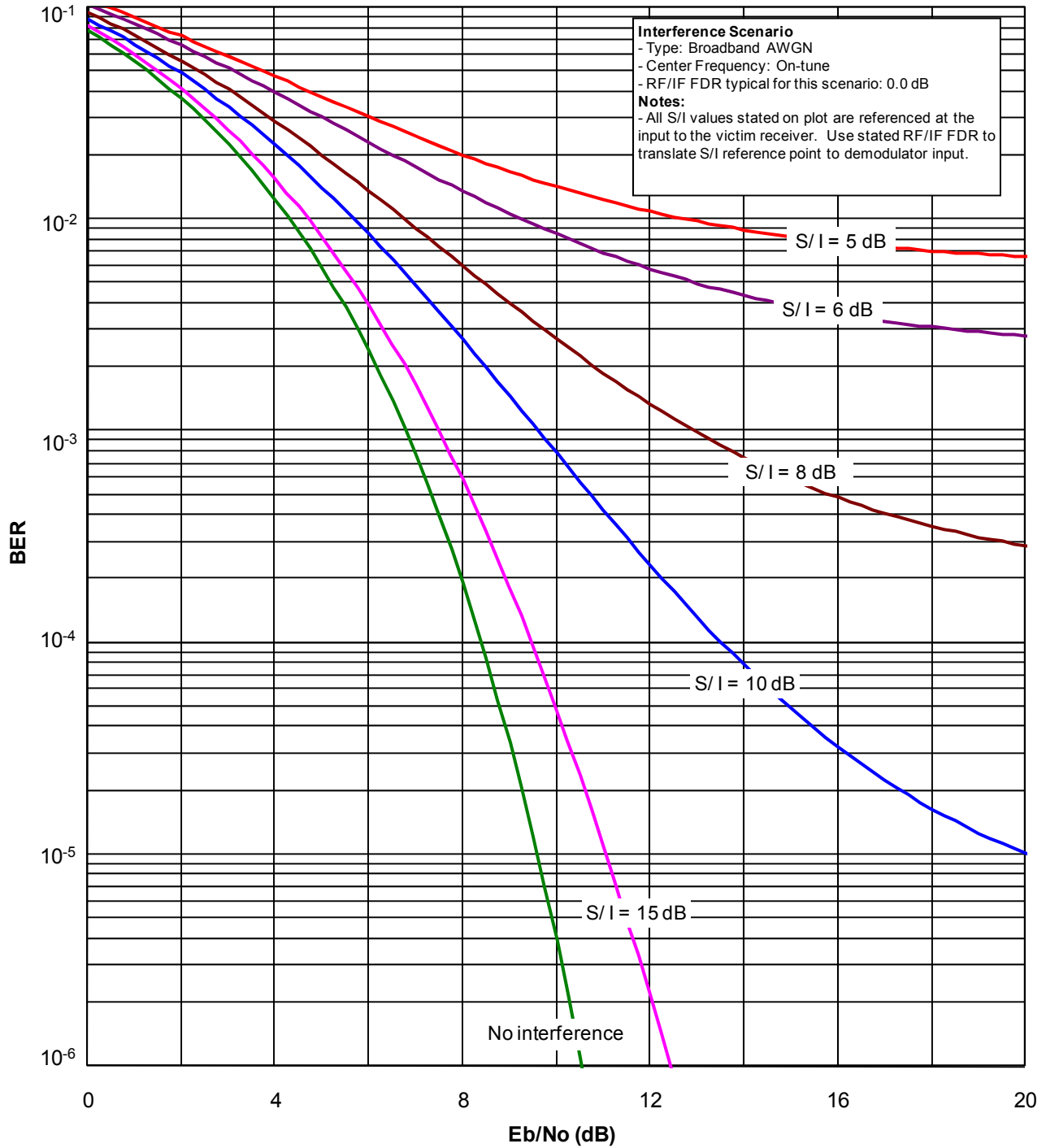

Figure 6.14-2. BER vs. E_b/N_0 Curves for OFDM Receiver with On-Tune Broadband AWGN Interference

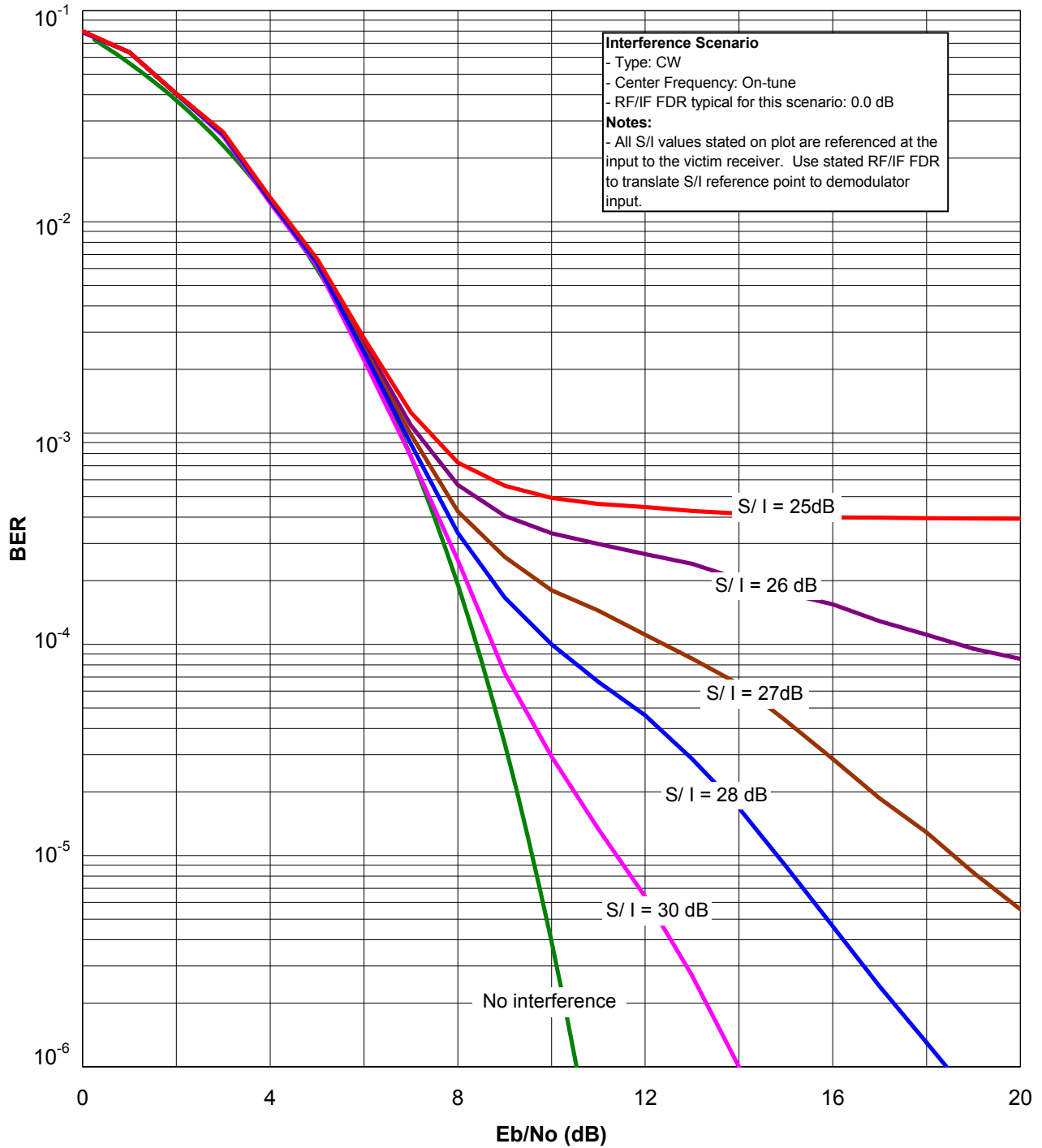

Figure 6.14-3. BER vs. E_b/N_0 Curves for OFDM Receiver with On-Tune CW Interference

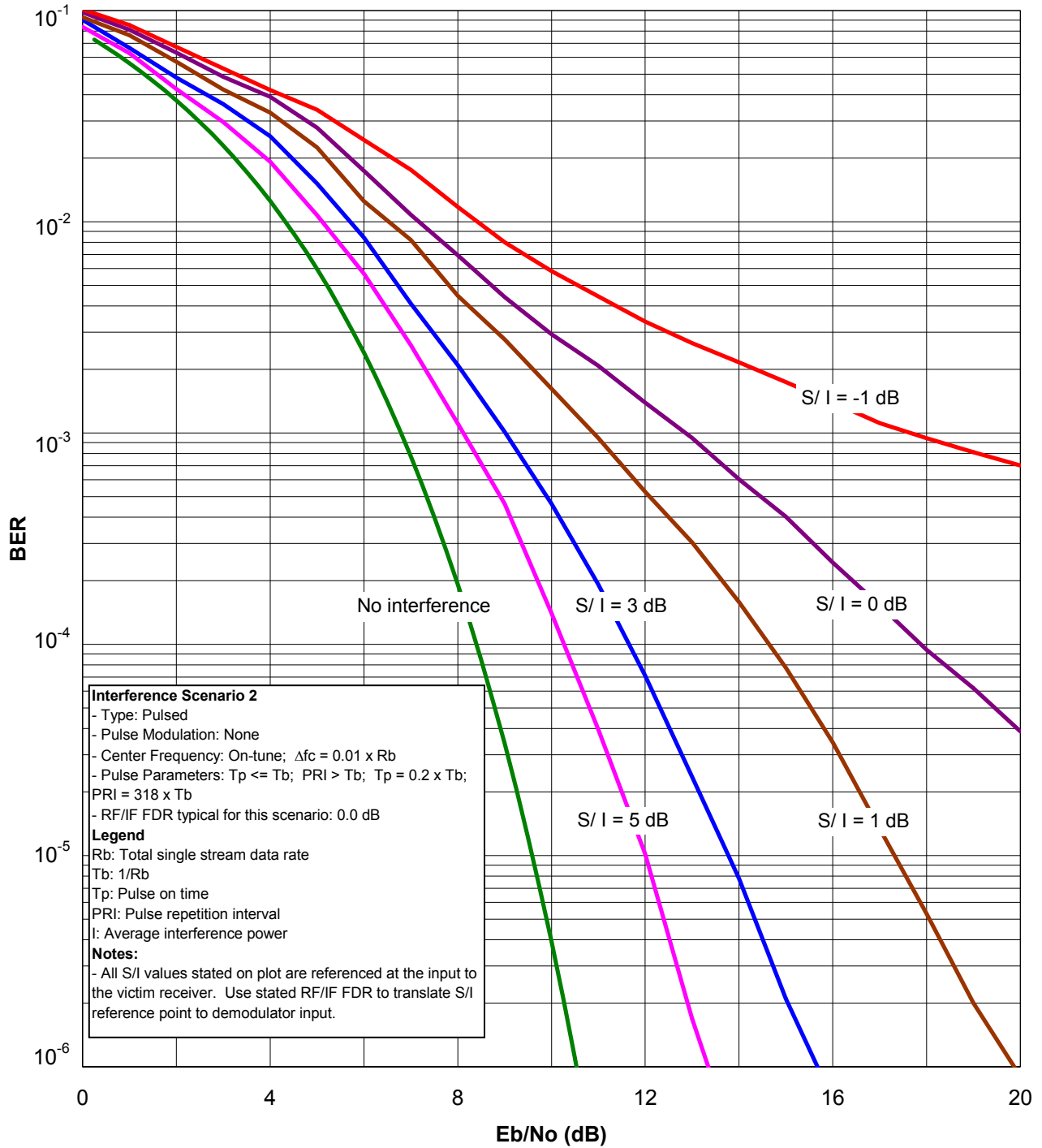

Figure 6.14-4. BER vs. E_b/N_0 Curves for OFDM Receiver with On-Tune Pulsed Interference Scenario 2

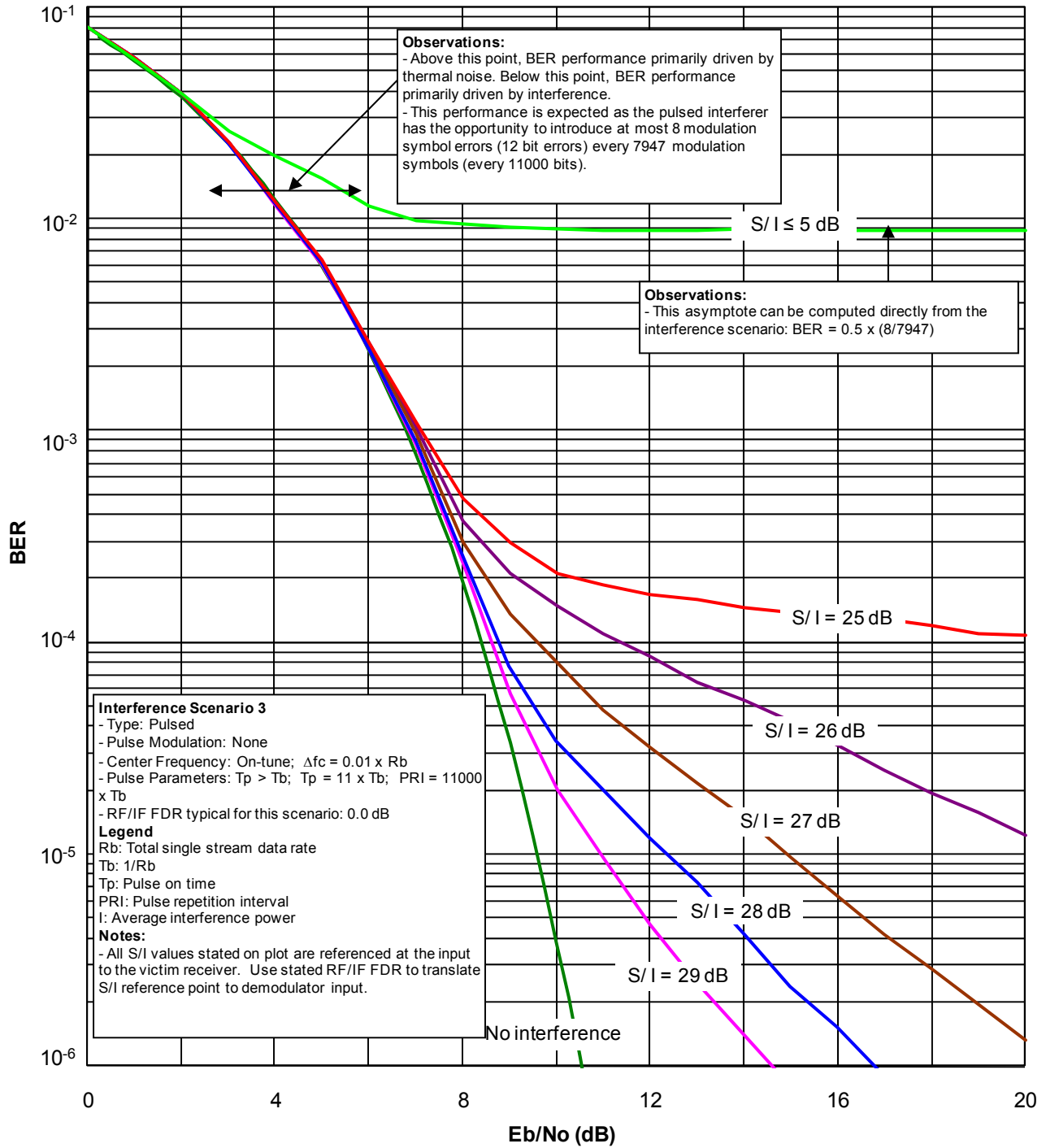

Figure 6.14-5. BER vs. E_b/N_o Curves for OFDM Receiver with On-Tune Pulsed Interference Scenario 3

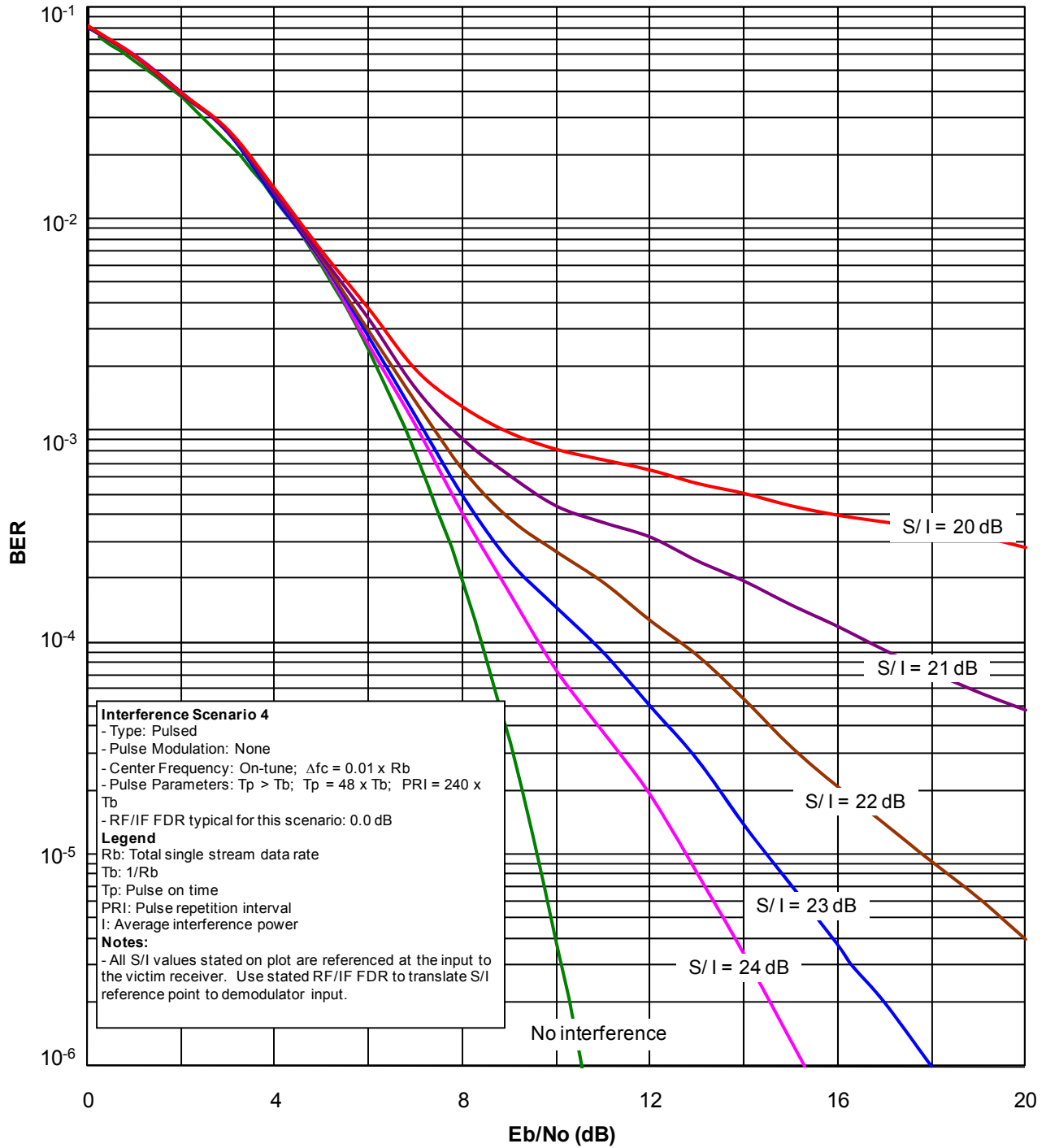

Figure 6.14-6. BER vs. E_b/N_0 Curves for OFDM Receiver with On-Tune Pulsed Interference Scenario 4

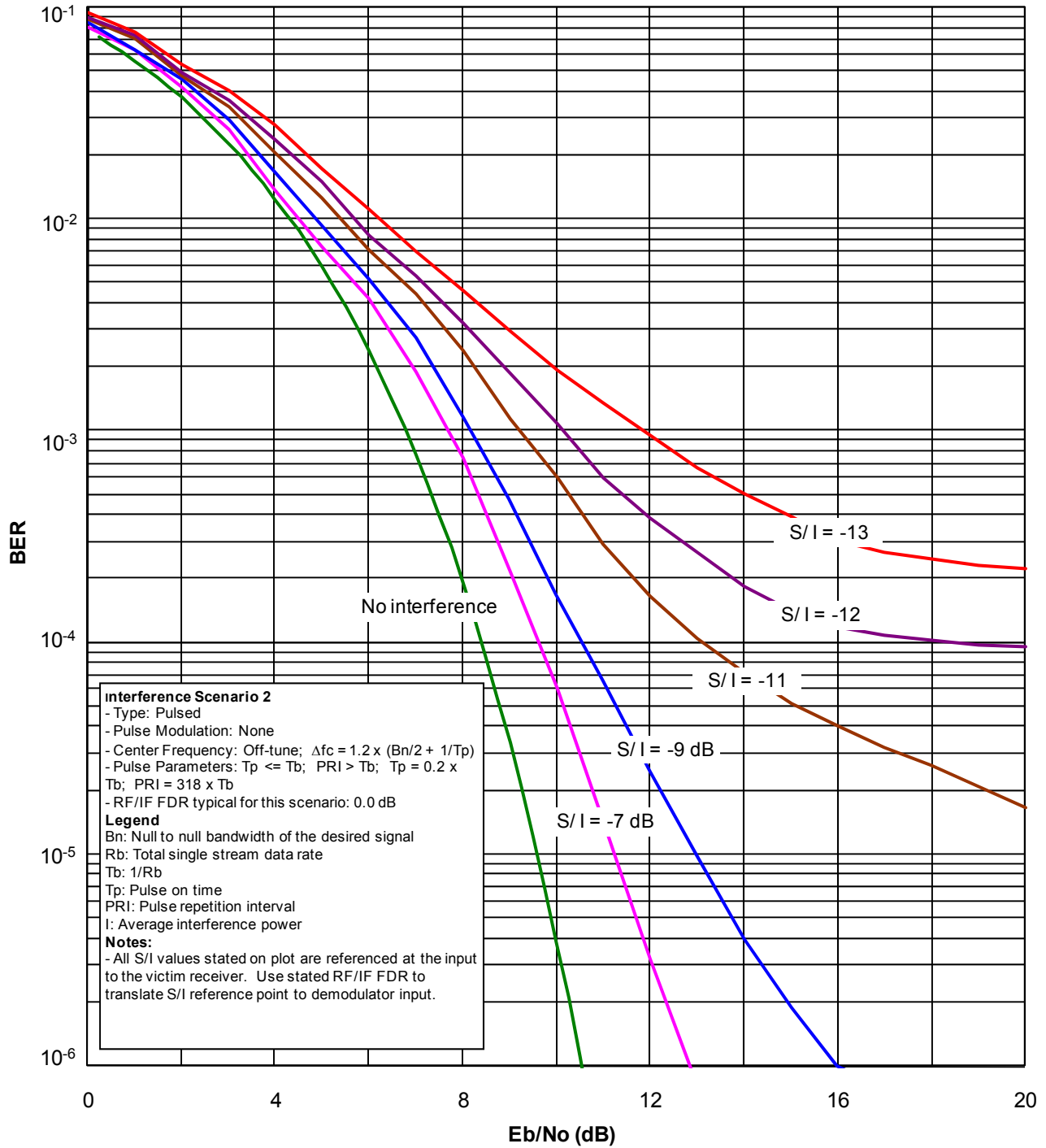

Figure 6.14-7. BER vs. E_b/N_0 Curves for OFDM Receiver with Off-Tune Pulsed Interference Scenario 2

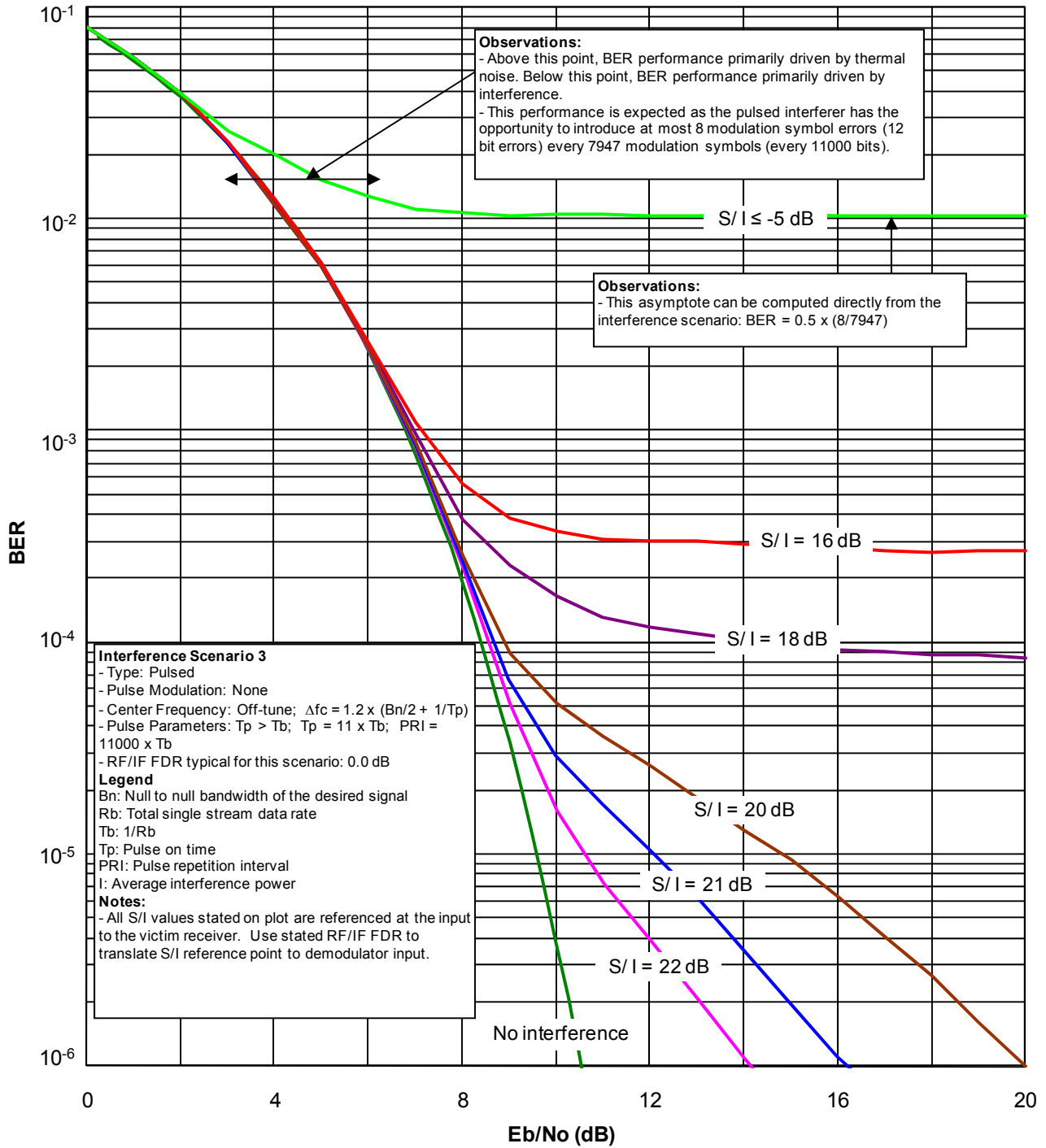

Figure 6.14-8. BER vs. E_b/N_o Curves for OFDM Receiver with Off-Tune Pulsed Interference Scenario 3

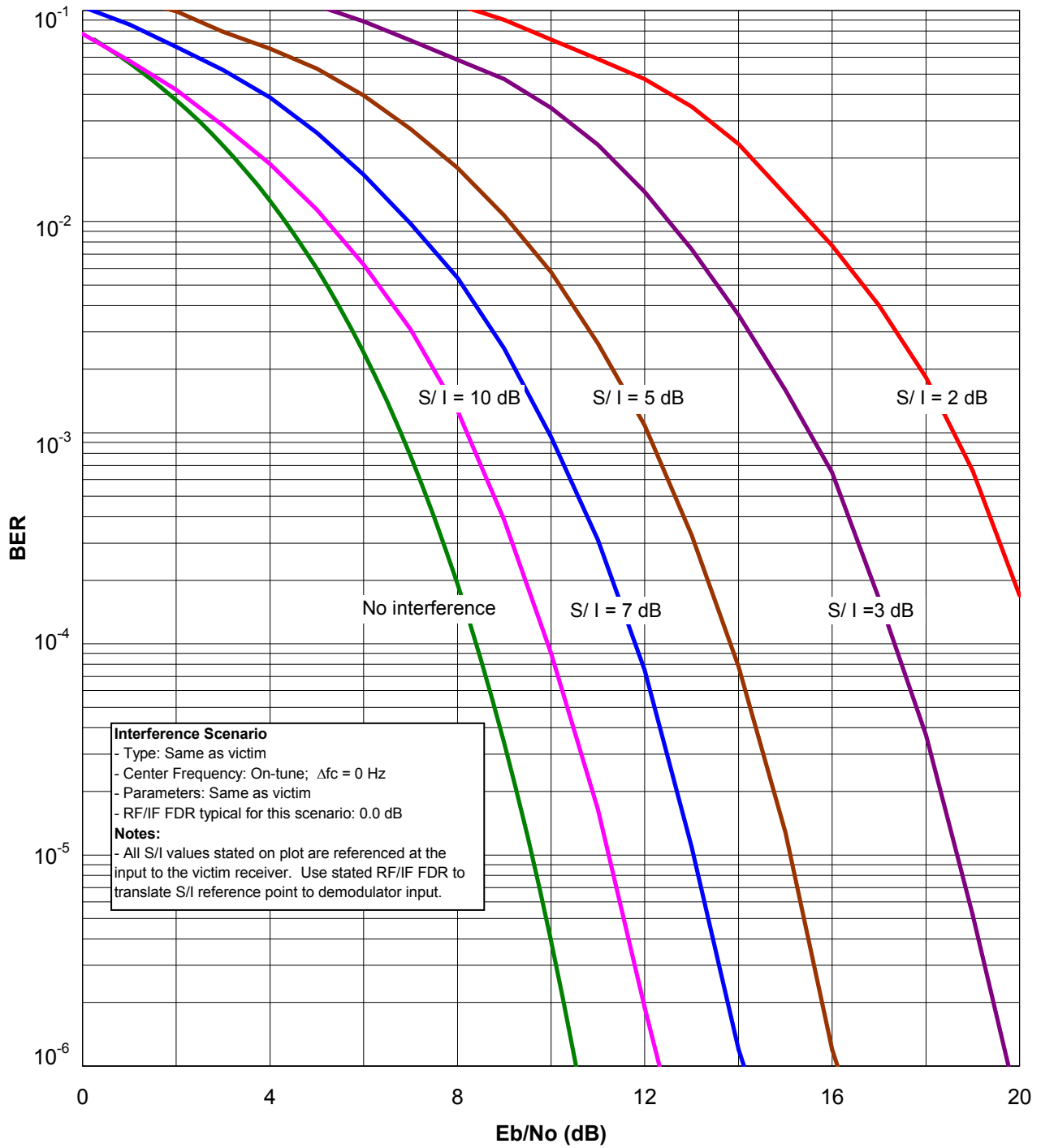

Figure 6.14-9. BER vs. E_b/N_o Curves for OFDM Receiver with Same as Victim Interference

6.15 COMPLEMENTRY CODE KEYING

6.15.1 Description

Complementary Code Keying (CCK) is the chosen modulation technique for 802.11b at rates of 5.5 Mbits/s and 11 Mbits/s and was originally adopted to replace Barker code in 1999. CCK is mainly an improvement over M-ary Biorthogonal Keying and uses a complex set of Walsh/Hadamard functions known as complementary codes. Each element of the code is one of $\{1, -1, j, -j\}$.

The input data select the spread function for CCK by choosing one vector from a set of 64 nearly orthogonal vectors. In doing so, 6 bits are modulated on each 8 chip spreading code symbol. Two additional bits are QPSK modulated resulting in a symbol consisting of 8 bits. The formula that defines the CCK code words has 4 phases and is shown below:

$$c = \{e^{j(\varphi_1+\varphi_2+\varphi_3+\varphi_4)}, e^{j(\varphi_1+\varphi_3+\varphi_4)}, e^{j(\varphi_1+\varphi_2+\varphi_4)}, \\ -e^{j(\varphi_1+\varphi_4)}, e^{j(\varphi_1+\varphi_2+\varphi_3)}, e^{j(\varphi_1+\varphi_3)}, -e^{j(\varphi_1+\varphi_2)}, e^{j\varphi_1}\} \quad (6-48)$$

One code word modulates all of the chips and the modulated chips are used for the QPSK rotation of the whole code vector. The three other code words modulate every code chip, every odd pair of chips and every odd quad of chips respectively.

CCK demodulation is performed by a Fast Walsh Transform block. This block acts as a bank of 64 correlators that determines which code word (6 bits) was transmitted. The other two bits from the 8 data code word are determined from the QPSK phase of the symbol. The bit error probability at the receiver with AWGN is:

$$P_e = \int_{-\sqrt{2E_s/N_o}}^{\infty} \left(\frac{1}{\sqrt{2\pi}} \int_{-(v+\sqrt{2E_s/N_o})}^{v+\sqrt{2E_s/N_o}} e^{-x^2/2} dx \right)^{M/2-1} e^{-v^2/2} dv \quad (6-49)$$

where $M = 8$ for the 11 Mbps mode and $M = 4$ for the 5.5 Mbps mode.

6.15.2 BER Curves

Figure 6-15-1 shows BER curves for a CCK receiver with on-tune broadband AWGN interference. Figure 6.15-2 shows BER curves for a CCK receiver with on-tune CW interference.

Figures 6.15-3, 6.15-4, and 6.15-5 show BER curves for a CCK receiver with various on-tune pulsed interference scenarios (as annotated on the plots). Figures 6.15-6 and 6.15-7 show BER curves for a CCK receiver with various off-tune pulsed interference scenarios (as annotated on the plots).

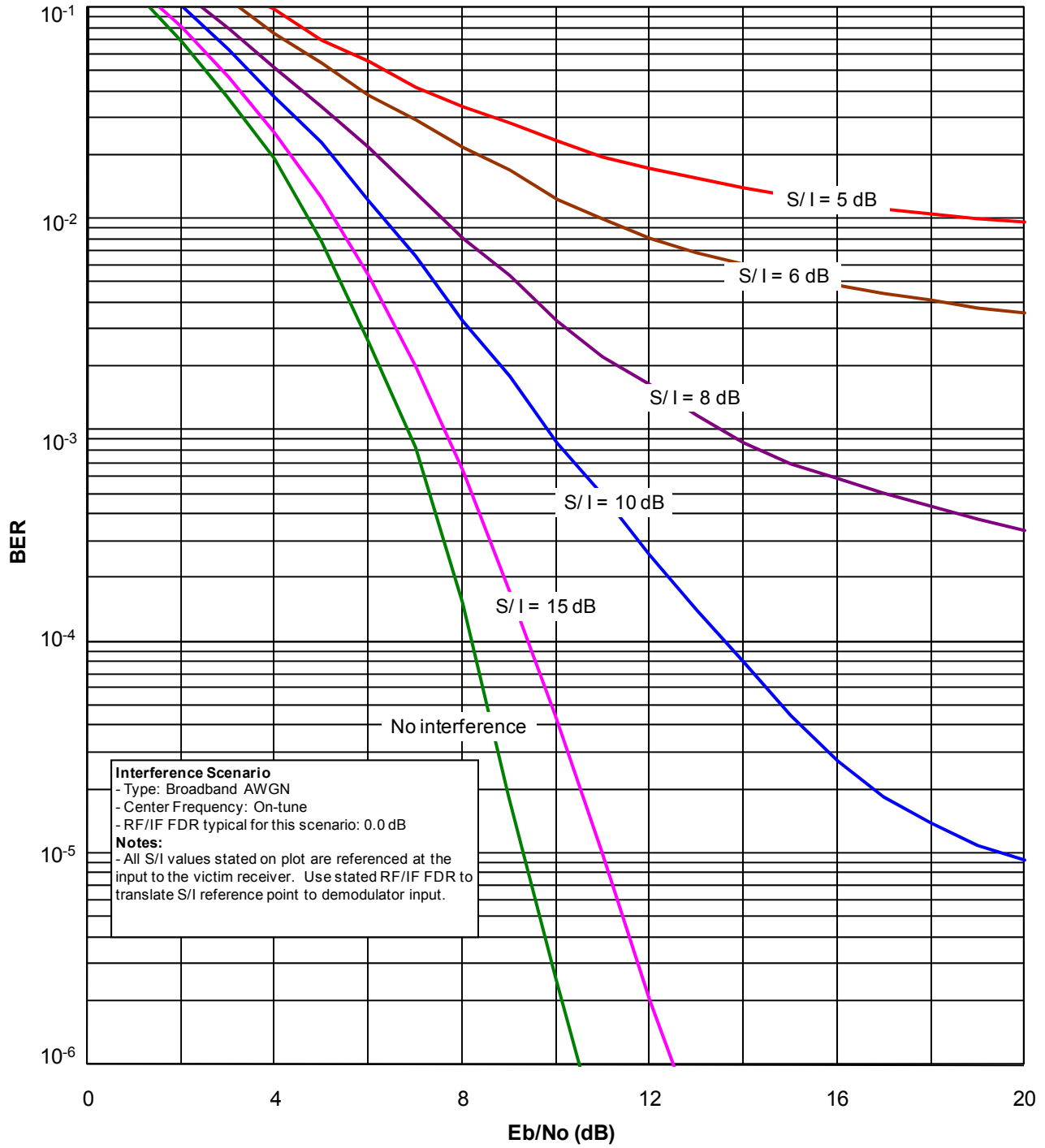

Figure 6.15-1. BER vs. E_b/N_o Curves for CCK Receiver with On-Tune Broadband AWGN Interference

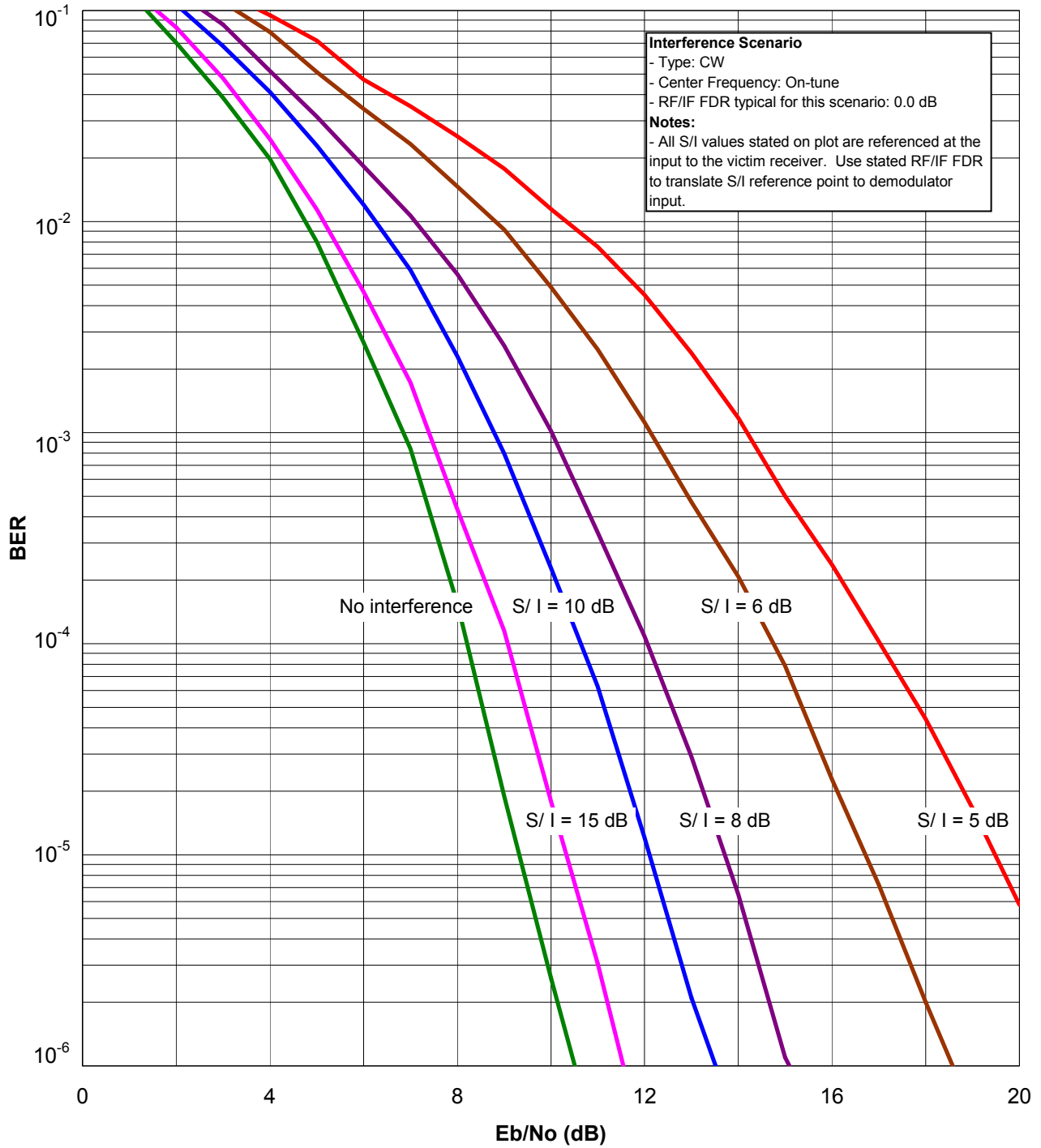

Figure 6.15-2. BER vs. E_b/N_0 Curves for CCK Receiver with On-Tune CW Interference

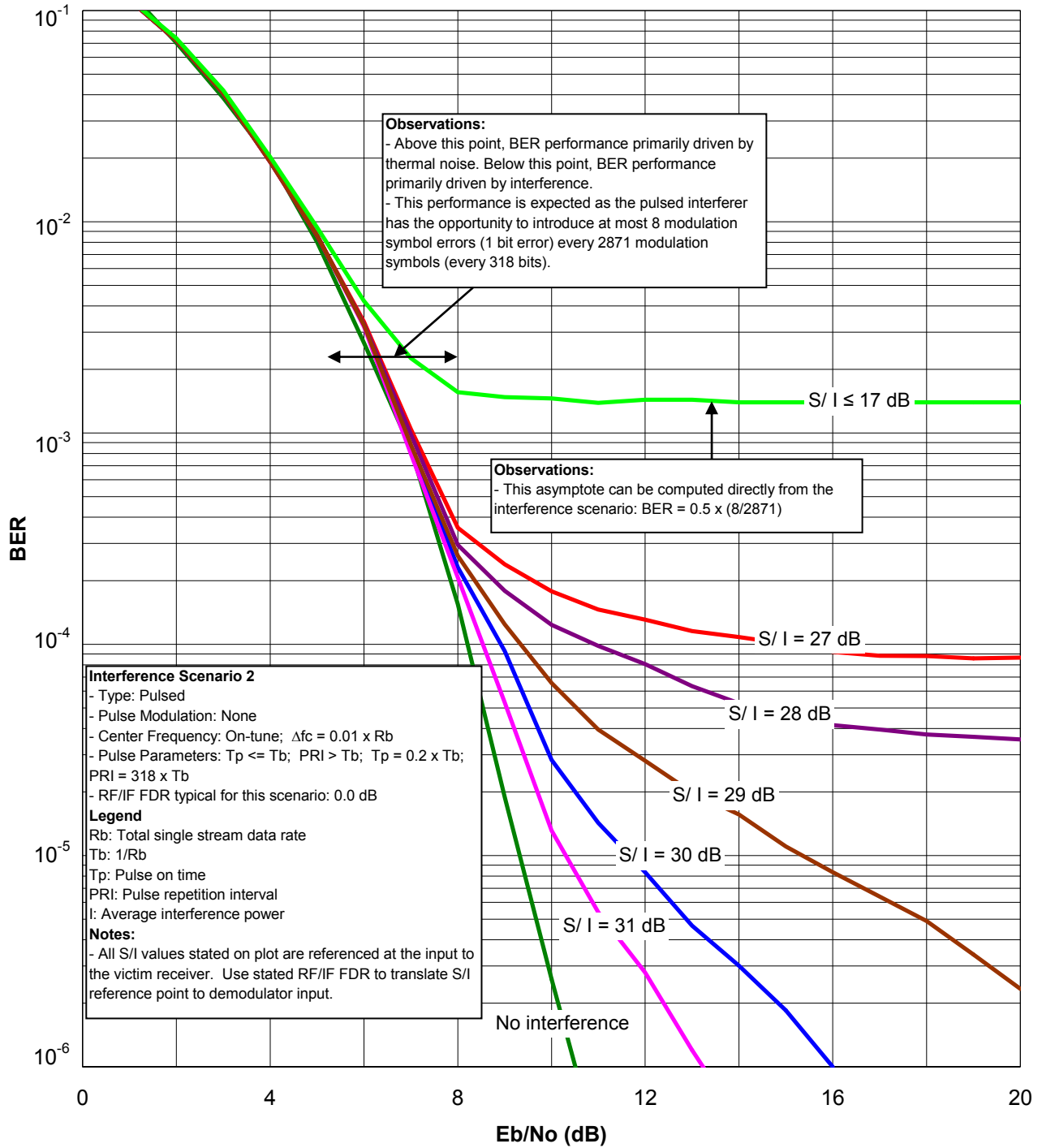

Figure 6.15-3. BER vs. E_b/N_o Curves for CCK Receiver with On-Tune Pulsed Interference Scenario 2

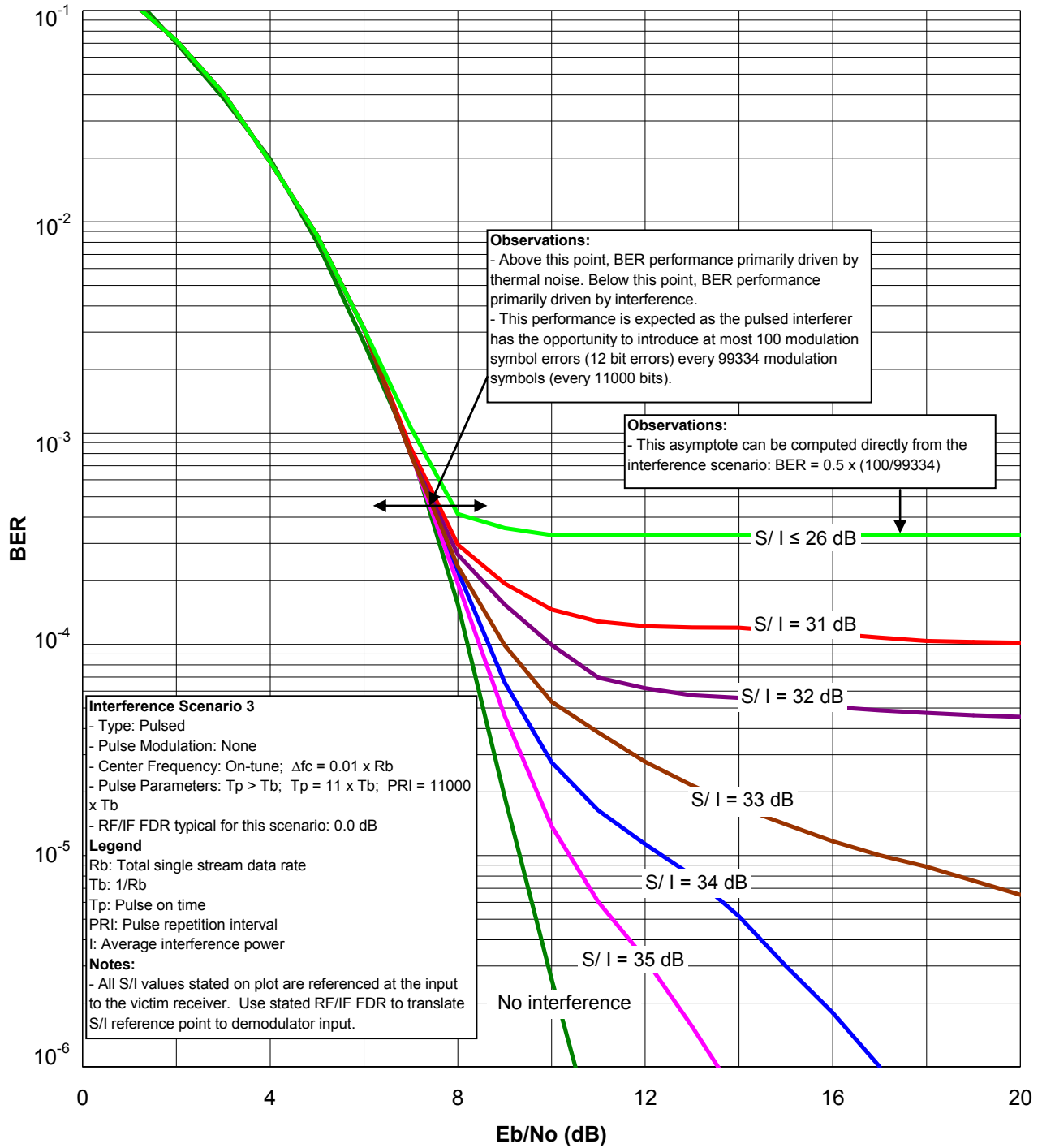

Figure 6.15-4. BER vs. E_b/N_0 Curves for CCK Receiver with On-Tune Pulsed Interference Scenario 3

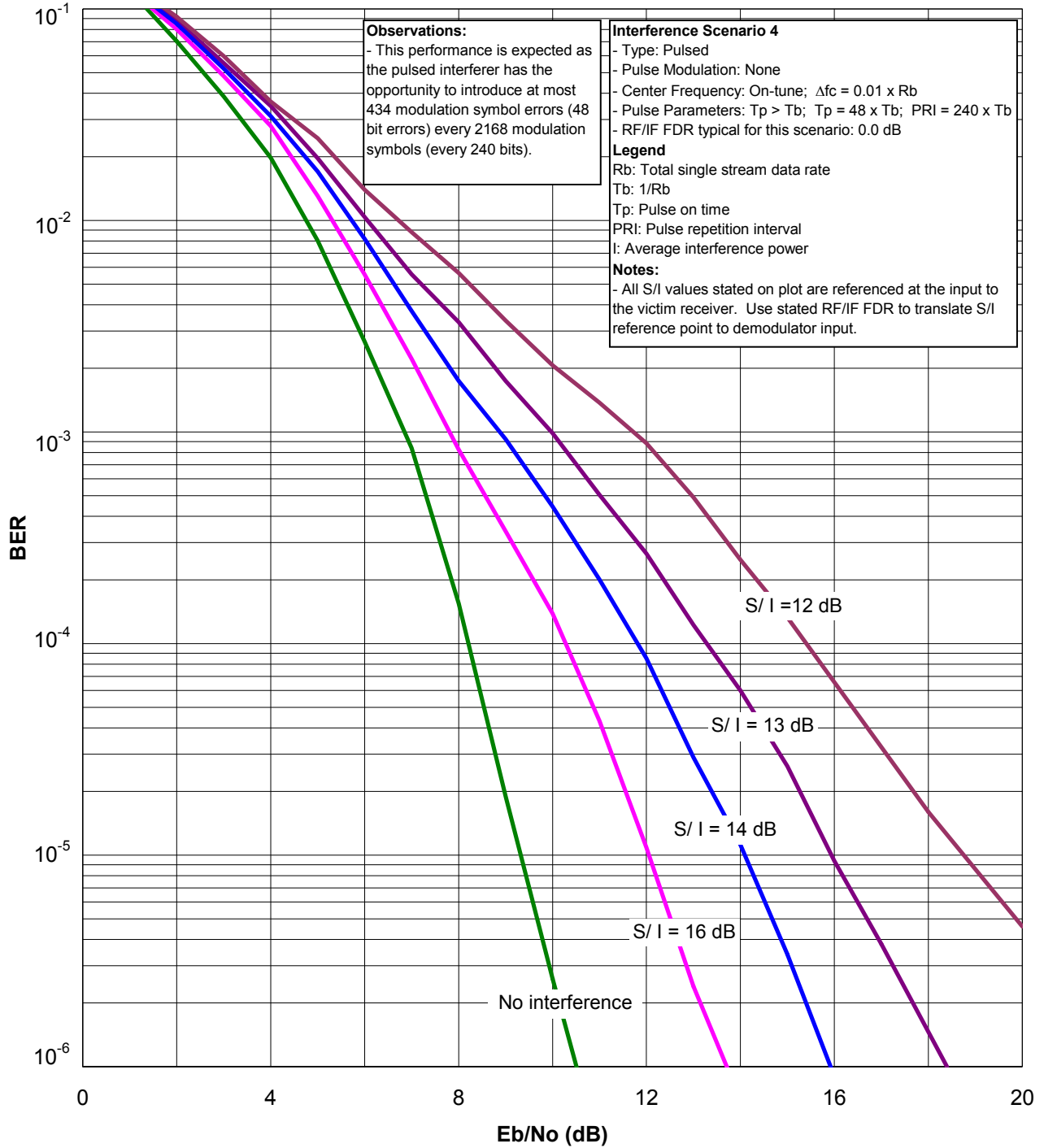

Figure 6.15-5. BER vs. E_b/N_0 Curves for CCK Receiver with On-Tune Pulsed Interference Scenario 4

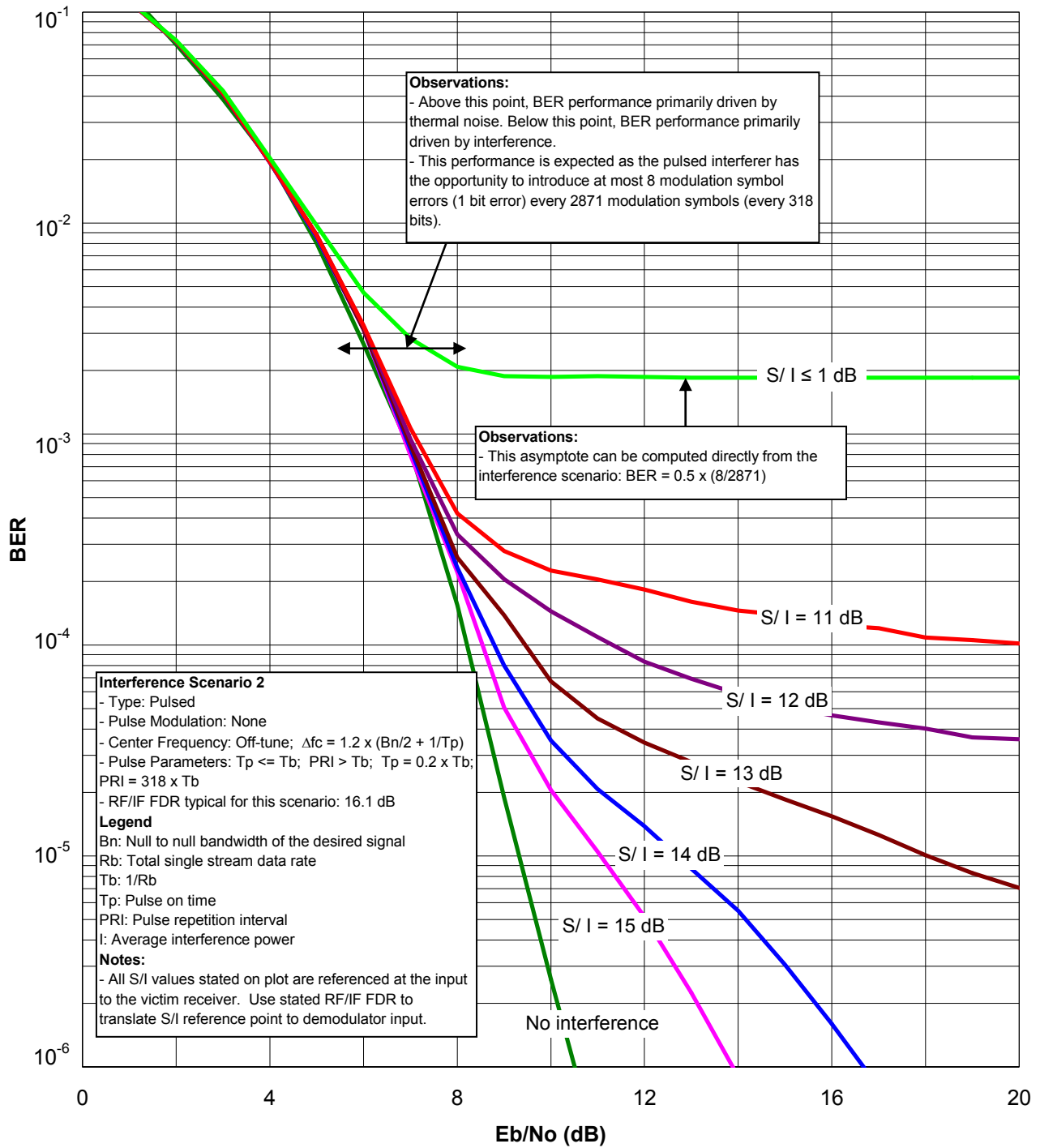

Figure 6.15-6. BER vs. E_b/N_o Curves for CCK Receiver with Off-Tune Pulsed Interference Scenario 2

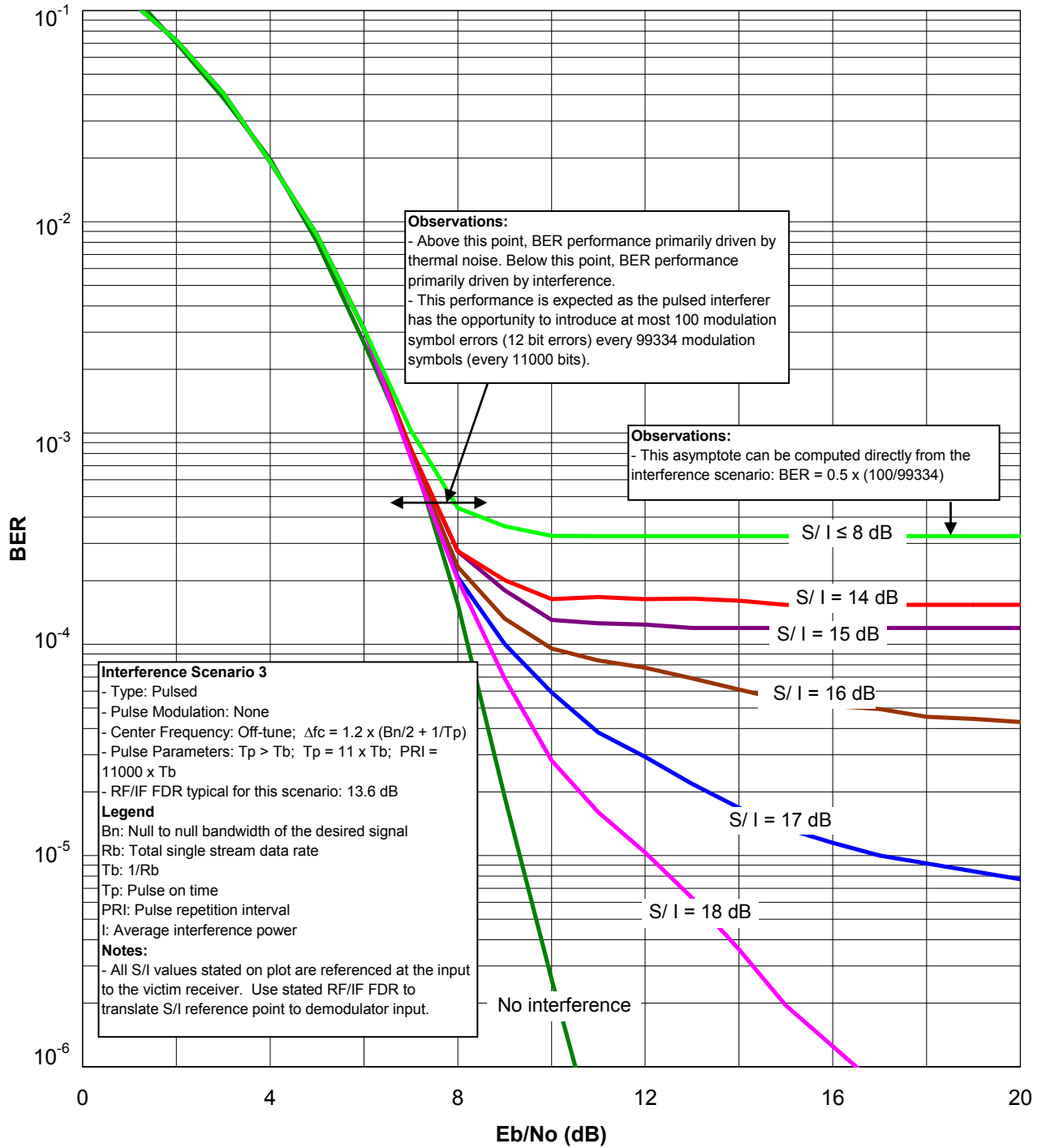

Figure 6.15-7. BER vs. E_b/N_o Curves for CCK Receiver with Off-Tune Pulsed Interference Scenario 3

6.16 PULSE POSITION MODULATION

6.16.1 Description

Pulse-Position Modulation (PPM) is a form of signal modulation in which M information bits are encoded by transmitting a single pulse in one of 2^M possible time-shifts. The single pulse $P(t)$ is

$$P(t) = \begin{cases} A & 0 \leq t < T_{pw} \\ 0 & \text{other} \end{cases}$$

$$T_{pw} = \frac{T_b}{2^M} \quad (6-50)$$

where T_{pw} is pulse duration and T_b is information bit duration.

A set of M information bits uniquely determines the time slot of a single pulse and therefore the transmitted pulses are orthogonal and do not overlap in time.

Different from continuously transmitting modulation schemes, PPM has a brief on time and a lengthy off time. Due to the short on time, PPM uses a significant amount of bandwidth for the amount of information transmitted. PPM has a high peak power to average power ratio compared to other common modulation techniques like PSK and FSK.

6.16.2 BER Curves

Figure 6-16-1 shows BER curves for a PPM ($M = 4$) receiver with on-tune broadband AWGN interference. Figure 6.16-2 shows BER curves for a PPM ($M = 4$) receiver with on-tune CW interference.

Figures 6.16-3, 6.16-4, and 6.16-5 show BER curves for a PPM ($M = 4$) receiver with various on-tune pulsed interference scenarios (as annotated on the plots).

Figures 6.16-6 and 6.16-7 show BER curves for a PPM ($M = 4$) receiver with various off-tune pulsed interference scenarios (as annotated on the plots).

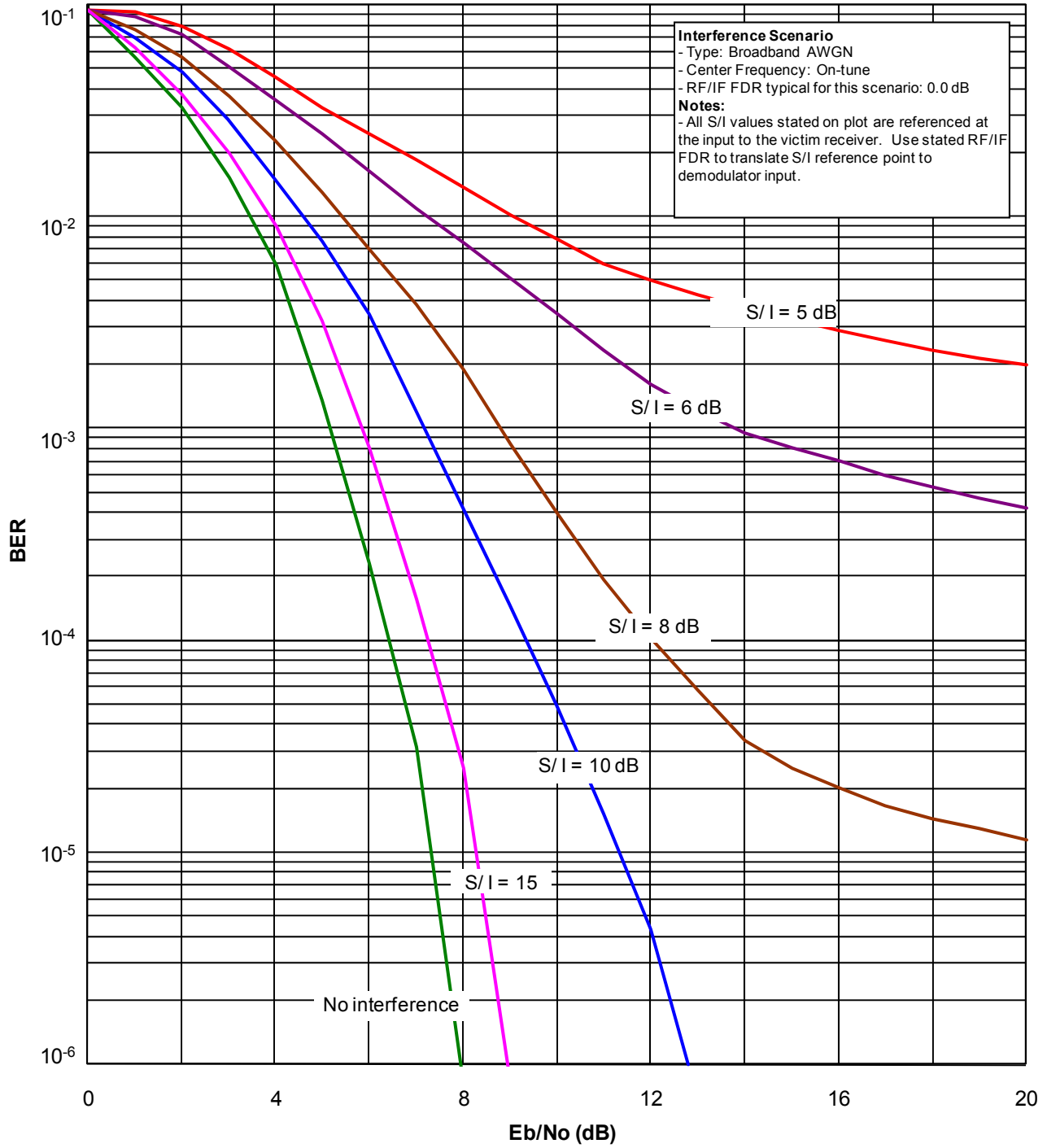

Figure 6.16-1. BER vs. E_b/N_o Curves for PPM ($M = 4$) Receiver with On-Tune Broadband AWGN Interference

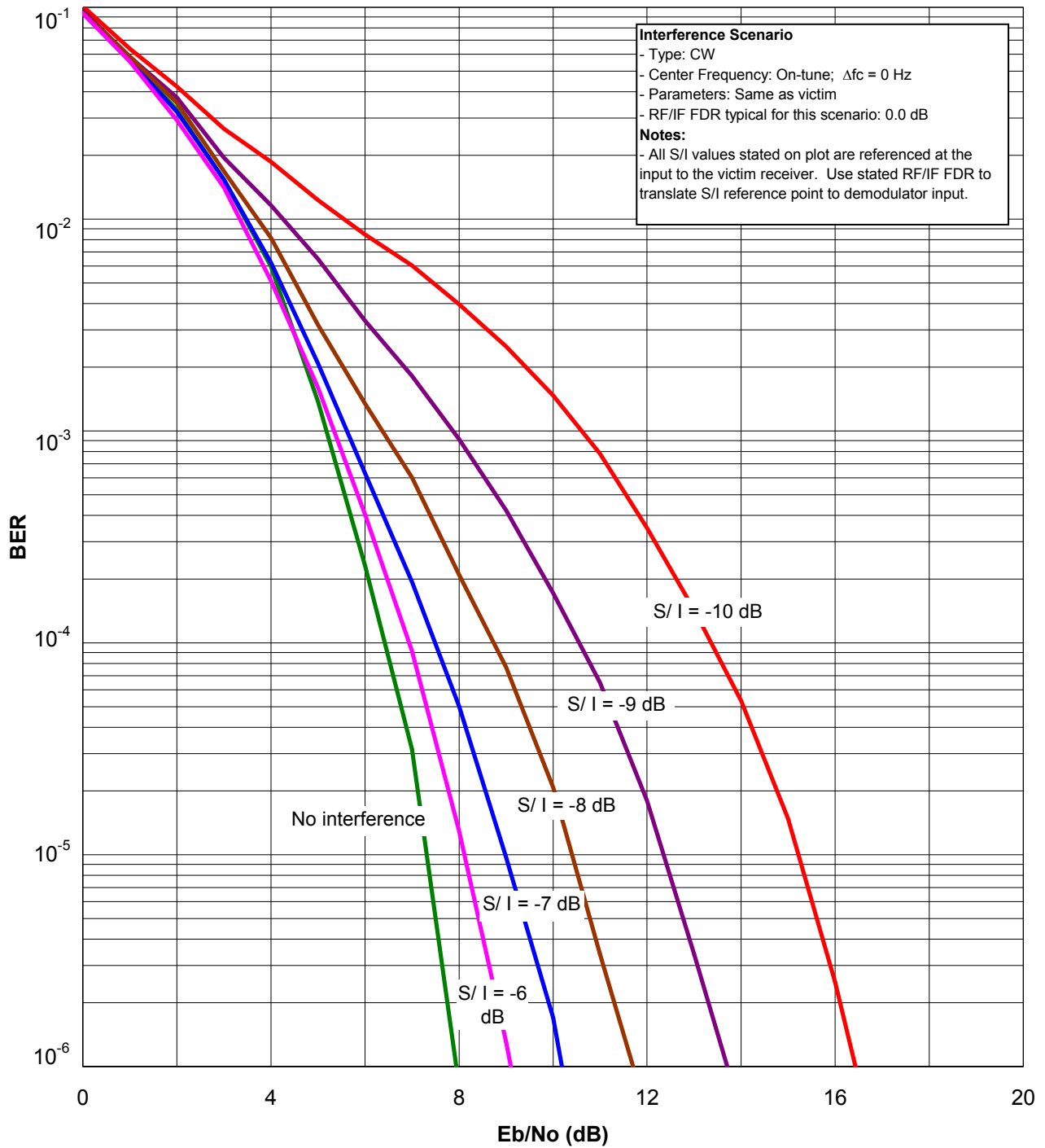

Figure 6.16-2. BER vs. E_b/N_0 Curves for PPM ($M = 4$) Receiver with On-Tune CW Interference

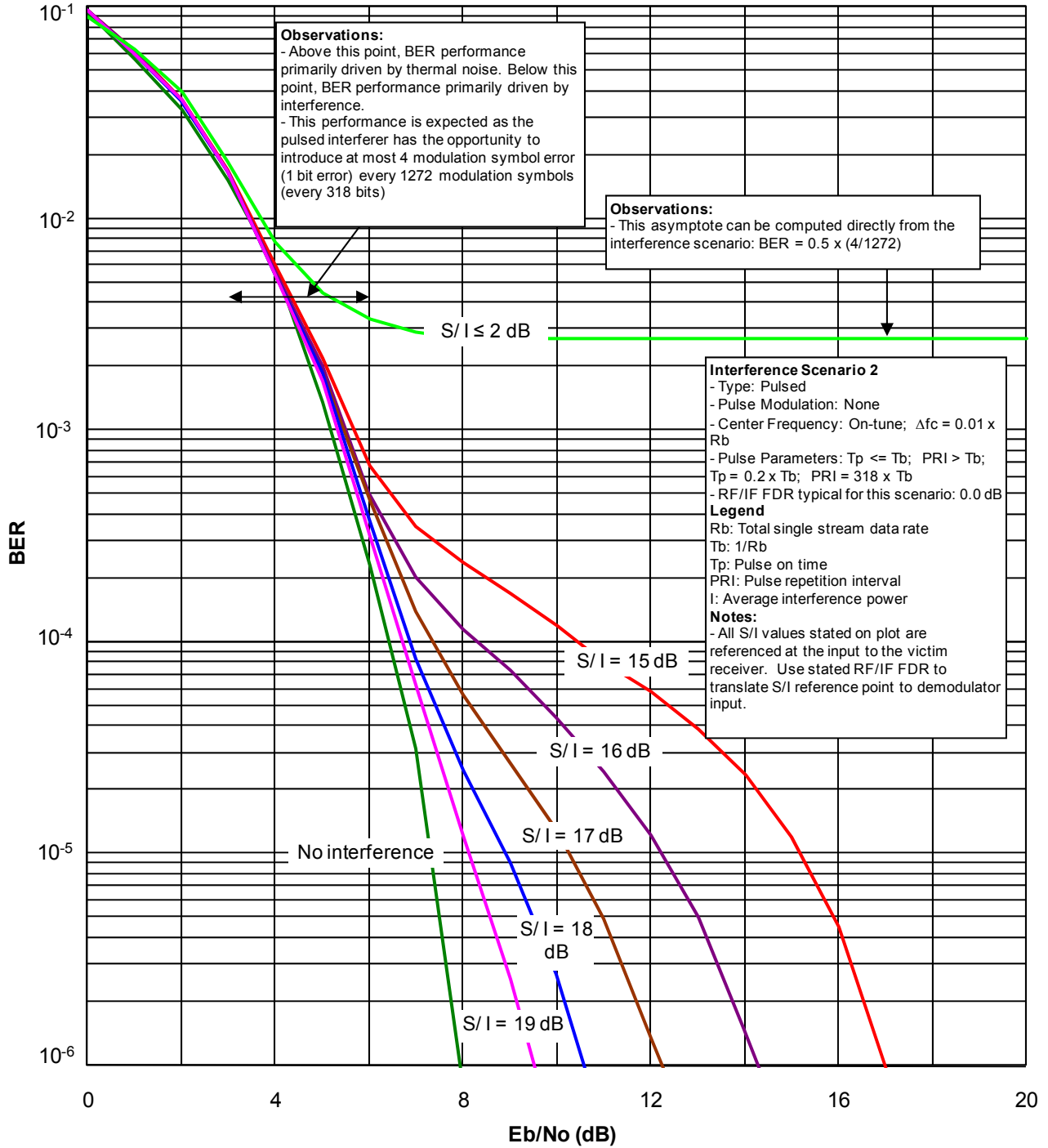

Figure 6.16-3. BER vs. E_b/N_o Curves for PPM ($M = 4$) Receiver with On-Tune Pulsed Interference Scenario 2

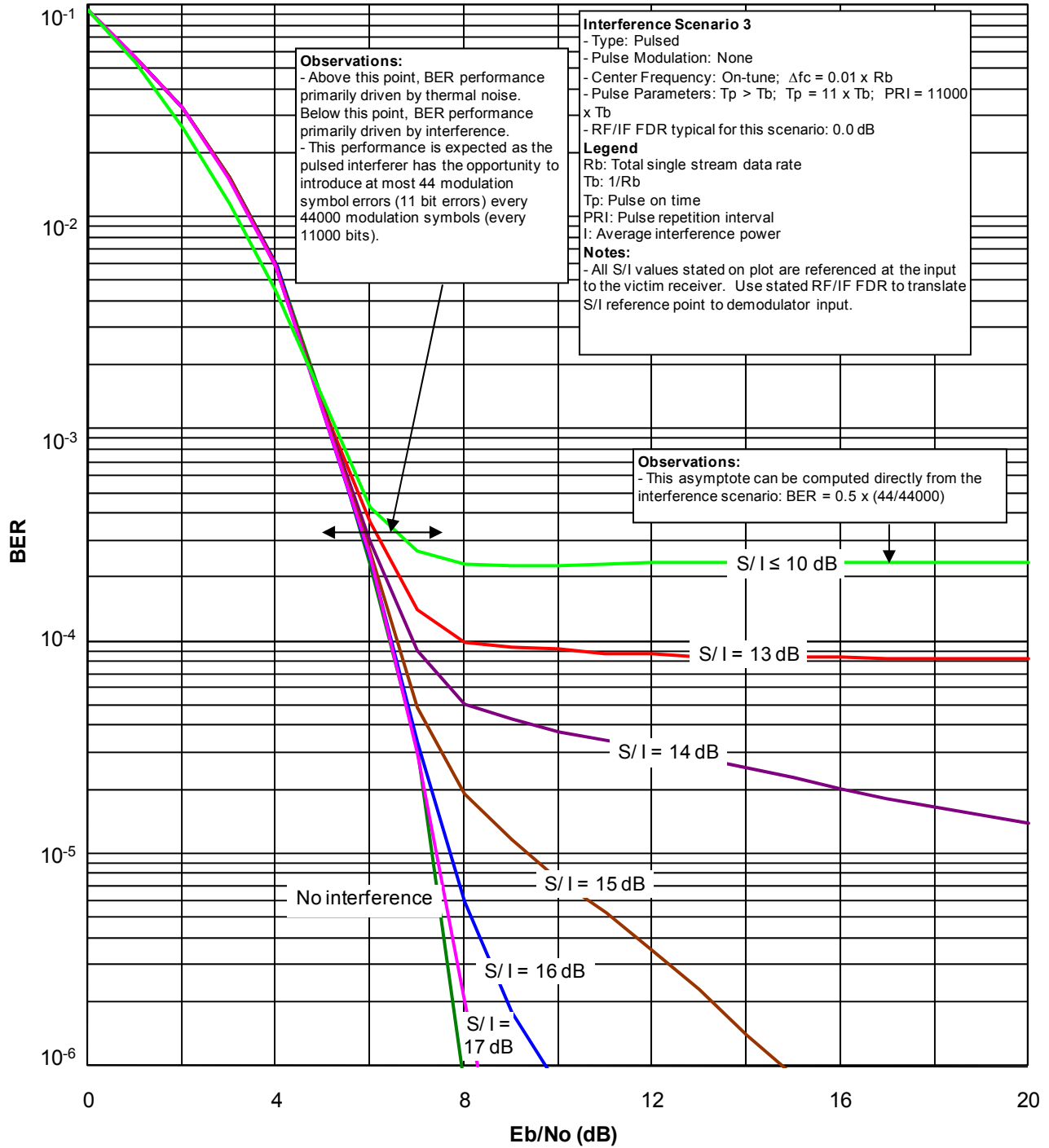

Figure 6.16-4. BER vs. E_b/N_o Curves for PPM ($M = 4$) Receiver with On-Tune Pulsed Interference Scenario 3

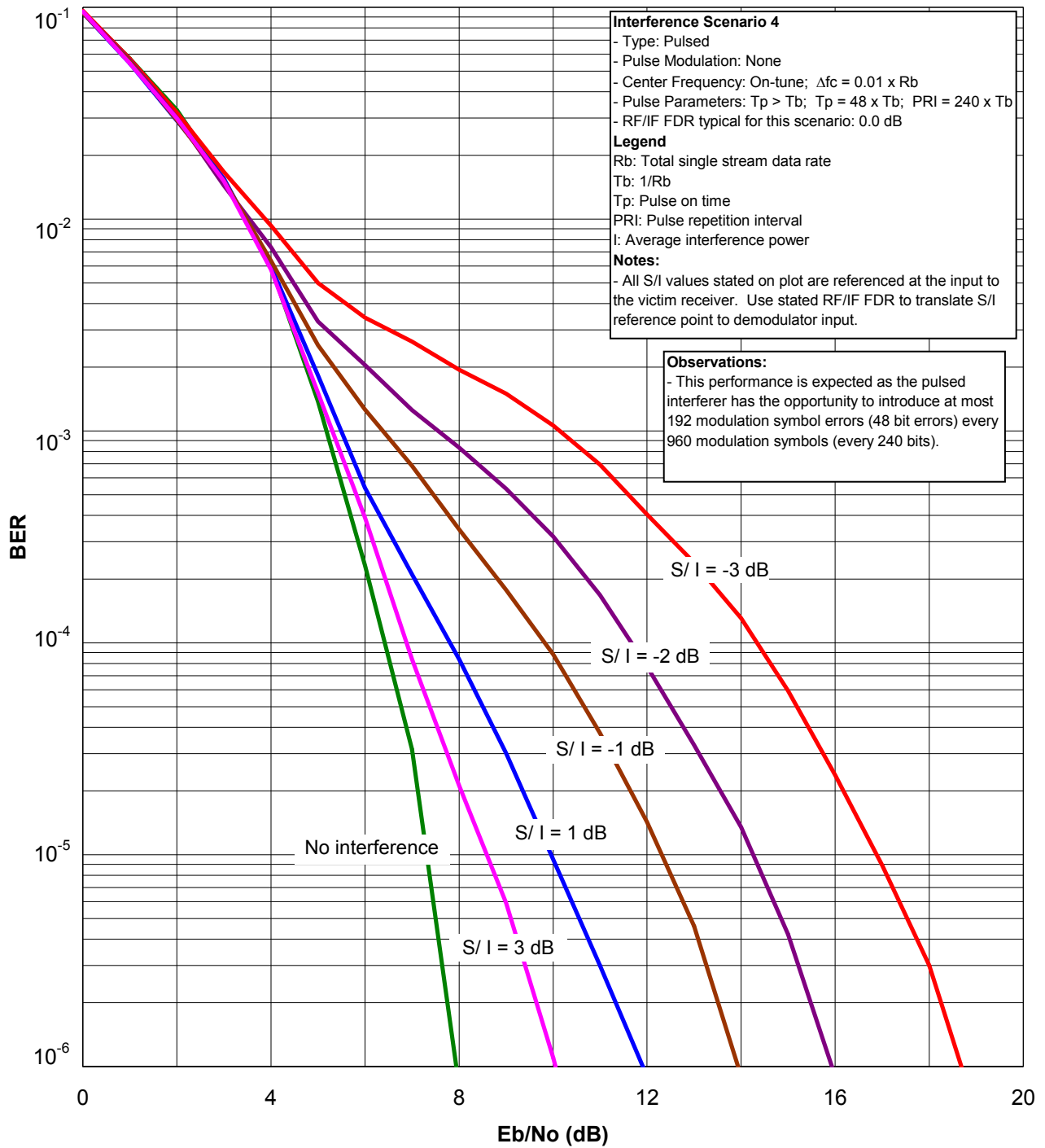

Figure 6.16-5. BER vs. E_b/N_0 Curves for PPM ($M = 4$) Receiver with On-Tune Pulsed Interference Scenario 4

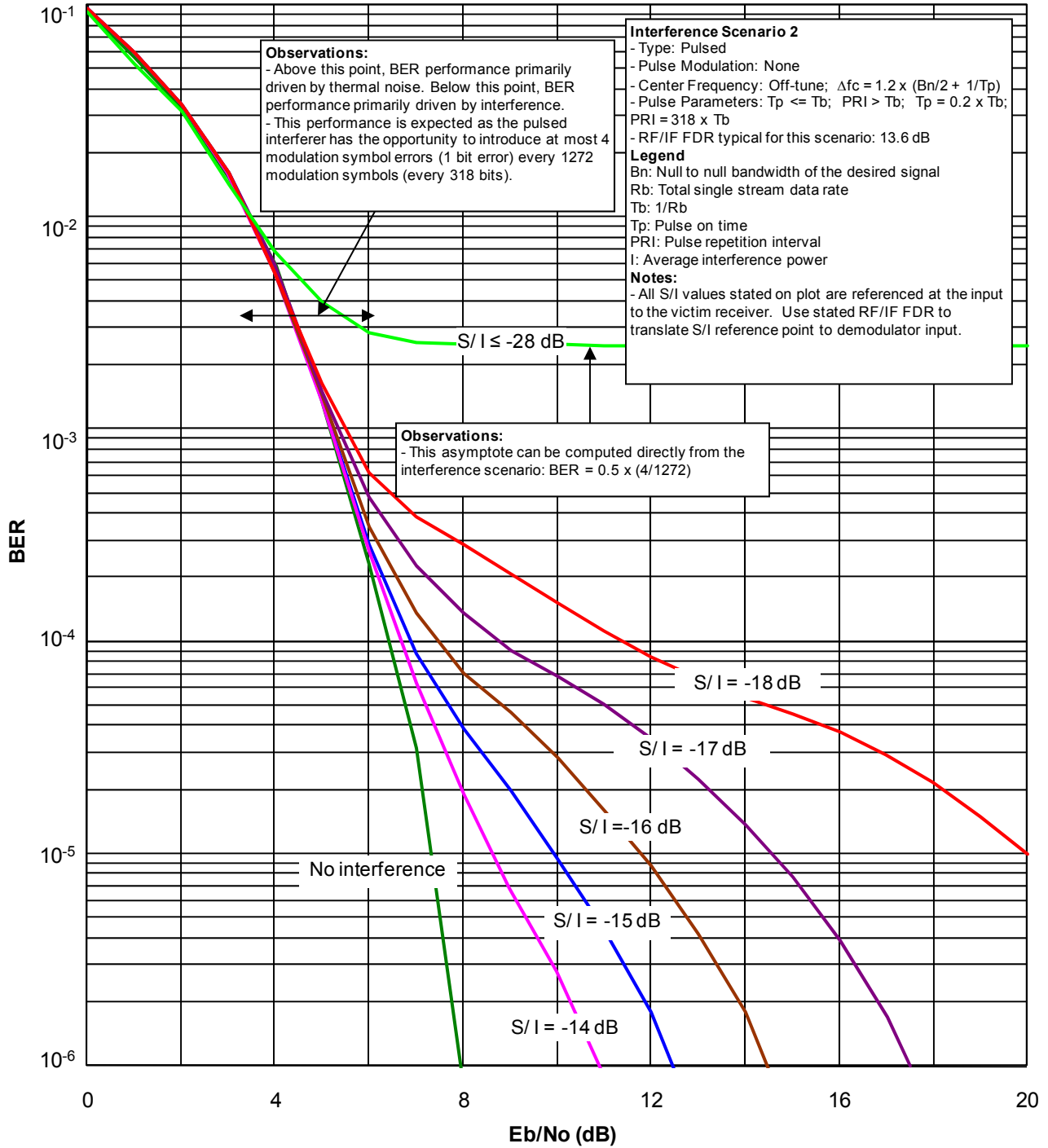

Figure 6.16-6. BER vs. E_b/N_o Curves for PPM ($M = 4$) Receiver with Off-Tune Pulsed Interference Scenario 2

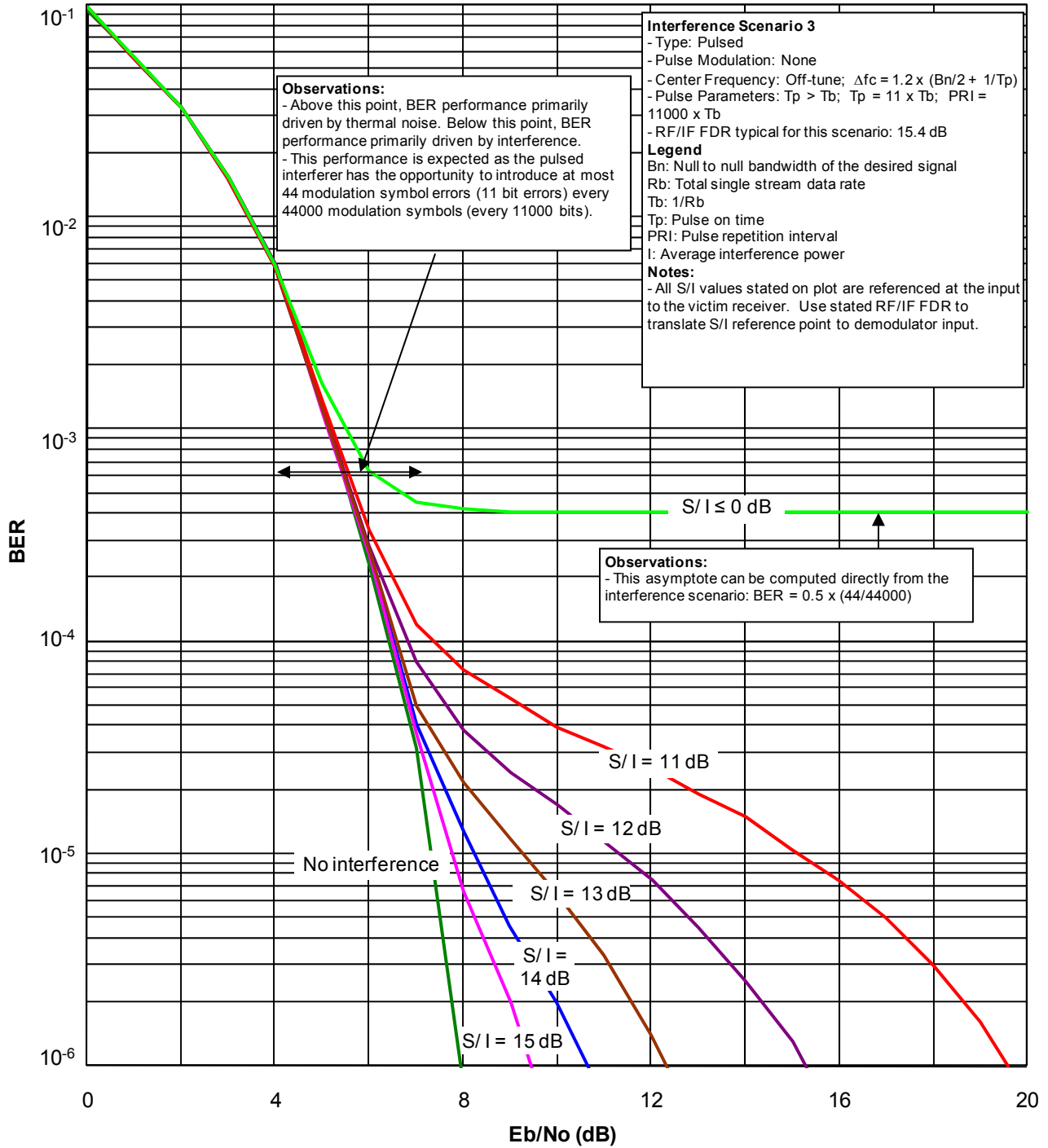

Figure 6.16-7. BER vs. E_b/N_o Curves for PPM ($M = 4$) Receiver with Off-Tune Pulsed Interference Scenario 3

SECTION 7 - FORWARD ERROR CORRECTION DECODER

This section describes the FEC decoder model for digital receivers. Decoder inputs and outputs are described for both hard-decision and soft-decision schemes. The properties of various block and convolutional decoders are specified. Some general procedures for calculating output BER are presented, including the case in which a receiver has concatenated FEC decoders. For hard-decision systems, curves that specify output BER as a function of input BER are displayed. For soft-decision systems, the demodulator and FEC decoder are treated as one combined module, and curves that specify output BER as a function of input E_b/N_0 are displayed.

7.1 INTRODUCTION

The purpose of the FEC decoder is to correct bit errors that are present in the demodulated data. These errors are the result of noise and interference in the channel. The errors are corrected by applying the decoding algorithm associated with the encoding algorithm used by the transmitter. Ideally, the bit sequence at the FEC decoder output is identical to the original bit sequence at the FEC encoder input.

FEC encoding involves adding redundancy, in the form of extra bits, to the information data. The FEC decoder removes this redundancy during the decoding process. There are two basic types of FEC code: block codes and convolutional codes.

There are limits to the capabilities of error-correction codes. In general, the reduction in BER is directly related to the amount of redundancy added. This section provides transfer functions and analysis techniques that quantify the performance of FEC decoders. This section also introduces some of the terminology that is specific to FEC technology and analysis.

7.2 HARD DECISION VERSES SOFT DECISION

The FEC decoder gets its input from the digital demodulator. A *hard-decision* demodulator makes a definite decision on each input bit waveform (which may be degraded with noise and interference) and then outputs that decision as a 0-bit or a 1-bit. This output bit waveform may use two voltage levels, say $-V$ and $+V$, to represent a logical 0-bit or 1-bit. There is nothing in the output data that indicates how reliable the demodulator decisions are.

A *soft-decision* demodulator does not make a definite decision on a given input bit waveform. Instead, it outputs a *bit likelihood indicator*; i.e., a value that indicates the likelihood that a 0-bit or 1-bit was sent. For example, the bit likelihood indicator for a given bit may be an integer value between 0 and 7, where 0 represents a very high likelihood that a 0-bit was sent and 7 represents a very low likelihood that a 0-bit was sent. The intermediate values from 1 to 6 represent intermediate likelihoods that a 0-bit was sent. For example, a value of 6 means that a 1-bit was probably sent but that there is some unreliability in that decision.

FEC decoders can be designed to work with either type of input. The decoder examines bit sequences for errors and, if it detects any, it makes correcting adjustments to the data. If the decoder input is a soft-decision input, the decoder can use the reliability information to improve its correction algorithm. Soft-decision demodulation and decoding can significantly improve the performance of a system that employs FEC coding, while adding very little to the system complexity and cost.

7.3 DECODER PERFORMANCE

For a hard-decision system, the input to the FEC decoder is a sequence of bits, including information bits and redundancy bits. Because the decoder removes the redundancy bits, the output bit rate is lower than the input bit rate. Typically, the decoder corrects some bit errors and the output BER is less than the input BER. The measure of performance in this Handbook for such an FEC decoder is the output BER expressed as a function of the input BER. The output BER is sometimes referred to as the *residual error rate*.

For a soft-decision system, the input to the FEC decoder is a sequence of bit likelihood indicators, one for each information bit and redundancy bit. As in hard decision, there is one decoder output bit for each information bit, and a bit error occurs whenever the decoder output bit is not equal to the corresponding original information bit. In this case, there is no BER at the decoder input because definite bit decisions have not been made at that point. For such a system, the most direct measure of performance combines demodulator and decoder effects. It specifies the decoder output BER as a function of E_b/N_o and S/I at the demodulator input.

7.4 TEMPORAL FLUCTUATIONS

If an undesired signal is intermittent, bit errors tend to be more numerous during the interference dwells, and less numerous between the dwells. If the interference is of sufficient strength and duration, the FEC decoder may be overloaded and the BER may approach $\frac{1}{2}$ during a dwell, which means the decoder output is completely random. Over the long term, this condition is likely to manifest itself as error bursts, separated by periods of relatively error-free operation.

However, the overload status of the decoder depends on how the interference dwell duration “matches up” with decoder properties such as code word duration. Interleaving (described in Section 7.5.8) can be used with hard-decision or soft-decision, block or convolutional codes to effectively convert long interference pulses into shorter, more uniformly distributed pulses. It should be noted that some FEC codes are designed specifically to handle burst errors. Such a code may be concatenated with a second code designed to combat random errors, in order to provide more complete error protection.

In both block and convolutional decoding, output bit errors tend to appear in clusters. However, the output BER, which is a long-term average quantity, is still a valid and useful measure of performance.

7.5 BLOCK CODES

7.5.1 General Concepts and Terminology

A block code is a mapping between two sets of bits: the information bits and the coded bits. The information bits are grouped into blocks with k bits per block. These information blocks are sometimes referred to in technical literature as messages. There are 2^k possible messages. The coded bits are grouped into blocks with n bits per block, where $n > k$. These code blocks are usually called code words. There are 2^n possible code words. The set of code words is called the code set, or simply the code.

The code mapping is the algorithm that associates every possible message to a unique code word. Thus, block encoding involves the addition of $n - k$ bits of redundancy to each message. Such a code is referred to as an (n, k) code. The ratio defined as $R = k/n$ is the code rate. The mapping is one-

to-one, which means that there are only 2^k valid code words, even though there are 2^n possible code words. The decoder exploits the fact that only some of the possible n -bit code words are valid, through a process called maximum likelihood decoding.

The weight of a code word is defined as the number of 1-bits in the code word. If all of the code words in the set have the same weight, the code is called an equal-weight code.

The distance between two code words is the number of bit positions in which the two code words differ. The minimum distance of a code set, which is designated d , is the smallest distance between all code word pairs in the set. In general, a larger minimum distance implies a more powerful error-correction capability.

A block code is linear if the modulo-2 sum of any two code words is also a code word. This property reduces the complexity of the FEC encoder.

A systematic code is one in which each code word is a concatenation of the message it represents with $r = n - k$ additional parity bits. This property reduces the complexity of the FEC encoder.

An example of a (7, 4) linear systematic code is shown in Table 7.5-1.

Table 7.5-1. Linear, Systematic (7, 4) Block Code

Message	Code Word
0000	0000000
0001	0001011
0010	0010110
0011	0011101
0100	0100111
0101	0101100
0110	0110001
0111	0111010
1000	1000101
1001	1001110
1010	1010011
1011	1011000
1100	1100010
1101	1101001
1110	1110100
1111	1111111

The set of code words in Table 7.5-1 may be generated from the set of messages by means of a matrix modulo-2 multiplication:

$$\mathbf{v} = \mathbf{uG} \tag{7-1}$$

where

\mathbf{v} = a code word ($v_7, v_6, v_5, v_4, v_3, v_2, v_1, v_0$)

\mathbf{u} = the corresponding message (u_3, u_2, u_1, u_0)

\mathbf{G} = the generator matrix $\begin{bmatrix} 1 & 0 & 0 & 0 & 1 & 0 & 1 \\ 0 & 1 & 0 & 0 & 1 & 1 & 1 \\ 0 & 0 & 1 & 0 & 1 & 1 & 0 \\ 0 & 0 & 0 & 1 & 0 & 1 & 1 \end{bmatrix}$

It may be confirmed by inspection that every pair of code words in Table 7.5-1 differs in at least three bit positions, so $d = 3$ for this code.

7.5.2 BER Calculation for Block Coding FEC

The output BER for a block FEC decoder depends on the number of bit errors per code word that the code can correct. This quantity is related to the minimum distance for the code as follows:

$$t = \text{Int}\left(\frac{d-1}{2}\right) \tag{7-2}$$

where

- t = number of correctable bit errors per code word
- $\text{Int}(x)$ = function that truncates x to an integer

In the (7, 4) linear block code example in Table 7.5-1, the minimum distance is 3, so the code can correct one bit error per code word. For a hard-decision decoder, calculating the output BER is a two-step process.

The first step is to calculate the probability of a code-word error, which is also called the *word error rate* (WER). This depends on the input BER and the parameters n , k , and t (which depends on d). If it is assumed that input bit errors are randomly distributed, and that the bit errors are statistically independent events, then the WER can be determined with a simple equation. The code word will be correct if it has from 0 to t bit errors (because the decoder can correct that many errors). Consequently, the WER is:

$$WER = 1 - \sum_{j=0}^t \frac{n!}{(n-j)!j!} BER_{in}^j (1 - BER_{in})^{n-j} \tag{7-3}$$

where

- BER_{in} = input BER

The second step, assuming a code word error has been made, is to estimate the number of erroneous bits in the output message. Assuming that all of the possible erroneous messages are equally likely, the output BER is:

$$BER_{out} = \frac{2^{k-1}}{2^k - 1} WER \tag{7-4}$$

The results of applying Equations 7-3 and 7-4 to the (7, 4) code example in Table 7.5-1 (with $t = 1$) are shown in Table 7.5-2.

Table 7.5-2. Performance of (7, 4) Linear Block Code With $t = 1$

Input BER	Output BER	Improvement
0.1	0.08	Negligible
0.01	0.0011	Order of magnitude
0.001	0.000011	Two orders of magnitude

For soft-decision block decoders, the decoding algorithms do not yield simple equations such as Equation 7-3. However, simulations show that soft-decision systems are about 2 dB better than hard-decision systems; i.e., E_b/N_o must be about 2 dB greater in a hard-decision system to get the same BER as in the corresponding soft-decision system.

As the above example illustrates, to calculate the output BER from the input BER for a hard-decision decoder, it is necessary to know the following:

- The number of bits per code word (n)
- The number of bits per message (k)
- The number of bits per code word that can be corrected (t)

A wide variety of FEC codes are available. These are typically specified by name and by the above parameters.

7.5.3 Bose-Chaudhuri-Hocquenghem Codes

An important class of block codes is the class of Bose-Chaudhuri-Hocquenghem (BCH) codes. These codes have the following properties:

- $n = 2^m - 1$, where m is an integer greater than 2
- $d \geq 2t + 1$
- $r = n - k \leq mt$, where r is the number of redundancy bits in a code word

The parameters for several BCH codes are listed in Table 7.5-3. A much more complete table with n extending to 1023 that can be used to obtain the number of correctable bit errors t is available in the literature.¹⁸

¹⁸ Shu Lin and Daniel Costello. *Error Control Coding: Fundamentals and Applications* Prentice-Hall, Inc. 1983.

Table 7.5-3. BCH Code Parameters for $n \leq 63$

n	k	t
7	4	1
15	11	1
	7	2
	5	3
31	26	1
	21	2
	16	3
	11	5
	6	7
63	57	1
	51	2
	45	3
	39	4
	36	5
	30	6
	24	7
	18	10
	16	11
	10	13
	7	15

Figure 7.5-1 shows the output BER vs. input BER curve for a hard-decision (255, 239) BCH decoder, which is implemented in some communications systems. This decoder has $r = 16$, $m = 8$, and $t = 2$. The curve was generated by applying Equations 7-3 and 7-4.

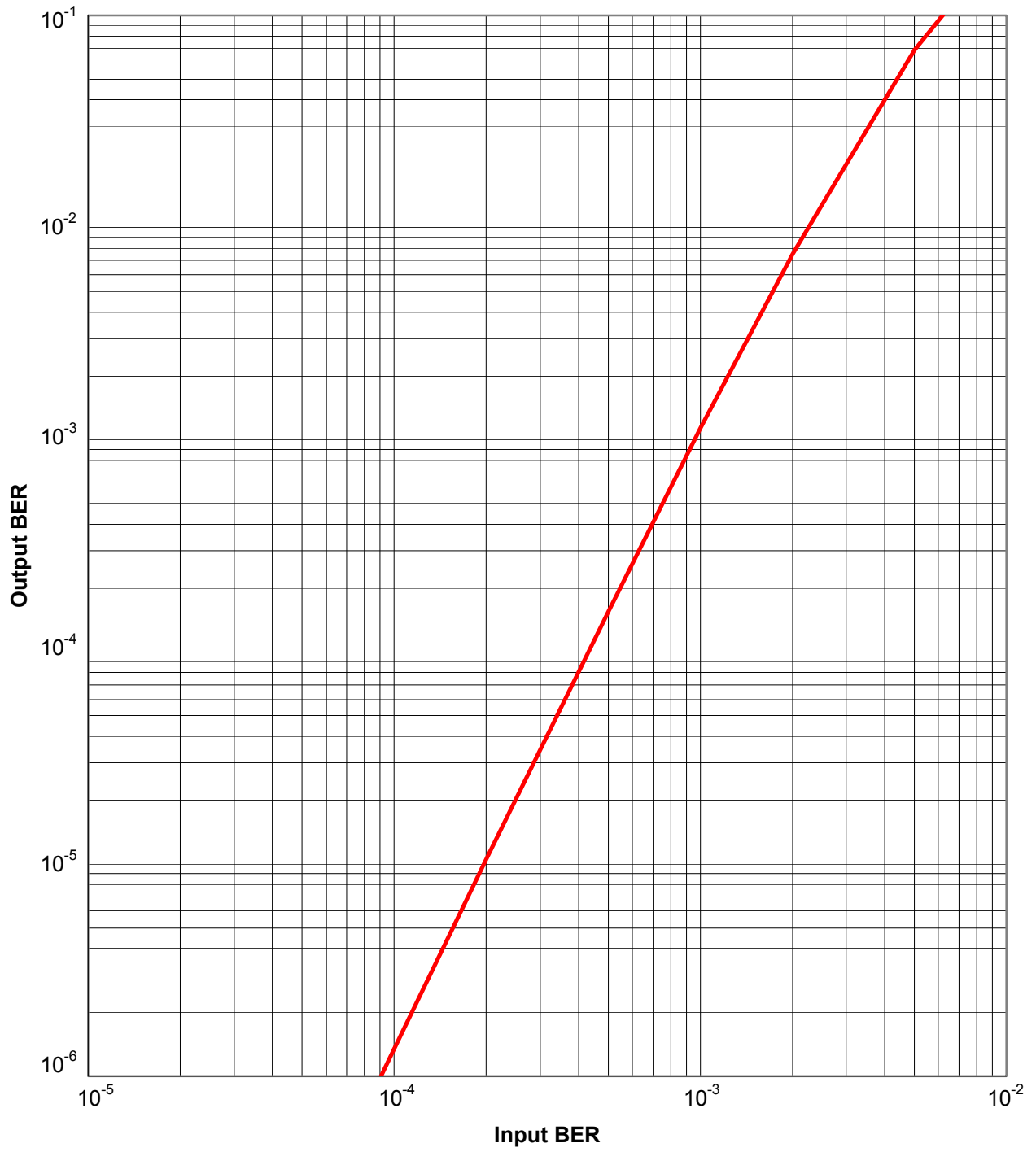

Figure 7.5-1. Output BER vs. Input BER Curve for Hard-decision (255, 239) BCH Decoder

7.5.4 Hamming Code

The Hamming code is a relatively simple single-error correcting code. It is a special case of the BCH code with $r = m$. Therefore, it has the following properties:

- $n = 2^r - 1$, where r is the number of redundancy bits in a code word
- $d = 3$
- $t = 1$

The (7, 4) Hamming code is sometimes extended to (8, 4) by the addition of another redundancy bit. This does not affect the number of correctable errors, but it is more convenient for implementing a system with the code rate $R = 1/2$.

Figure 7.5-2 shows the output BER vs. input BER curve for a hard-decision extended (8, 4) Hamming decoder. This decoder has $r = m = 3$. The curve was generated by applying Equations 7-3 and 7-4.

Figure 7.5-3 shows BER vs. E_b/N_0 curves for a soft-decision extended (8, 4) Hamming decoder and for various demodulator types. For these curves, the demodulator and FEC decoder are treated as one combined module.

7.5.5 Hadamard Code

This (n, k) block code is based on the Hadamard matrix, which is an $n \times n$ matrix with the property that all of the rows (except one) have an equal number of 1-bits and 0-bits. The code words are simply the rows of the matrix. Other properties of the Hadamard code are

- $n = 2^k$
- $d = n/2$
- $t = \text{Int}[(d - 1)/2] = \text{Int}[(n - 2)/4]$

A typical example is the (64, 6) Hadamard code, which can correct up to 15 bits per code word. This capability is made possible by the 58 bits of redundancy that are added to each 6-bit message. Hadamard matrices may be used to define code sets for DS spread-spectrum systems. The equal-weight property is desirable for this application.

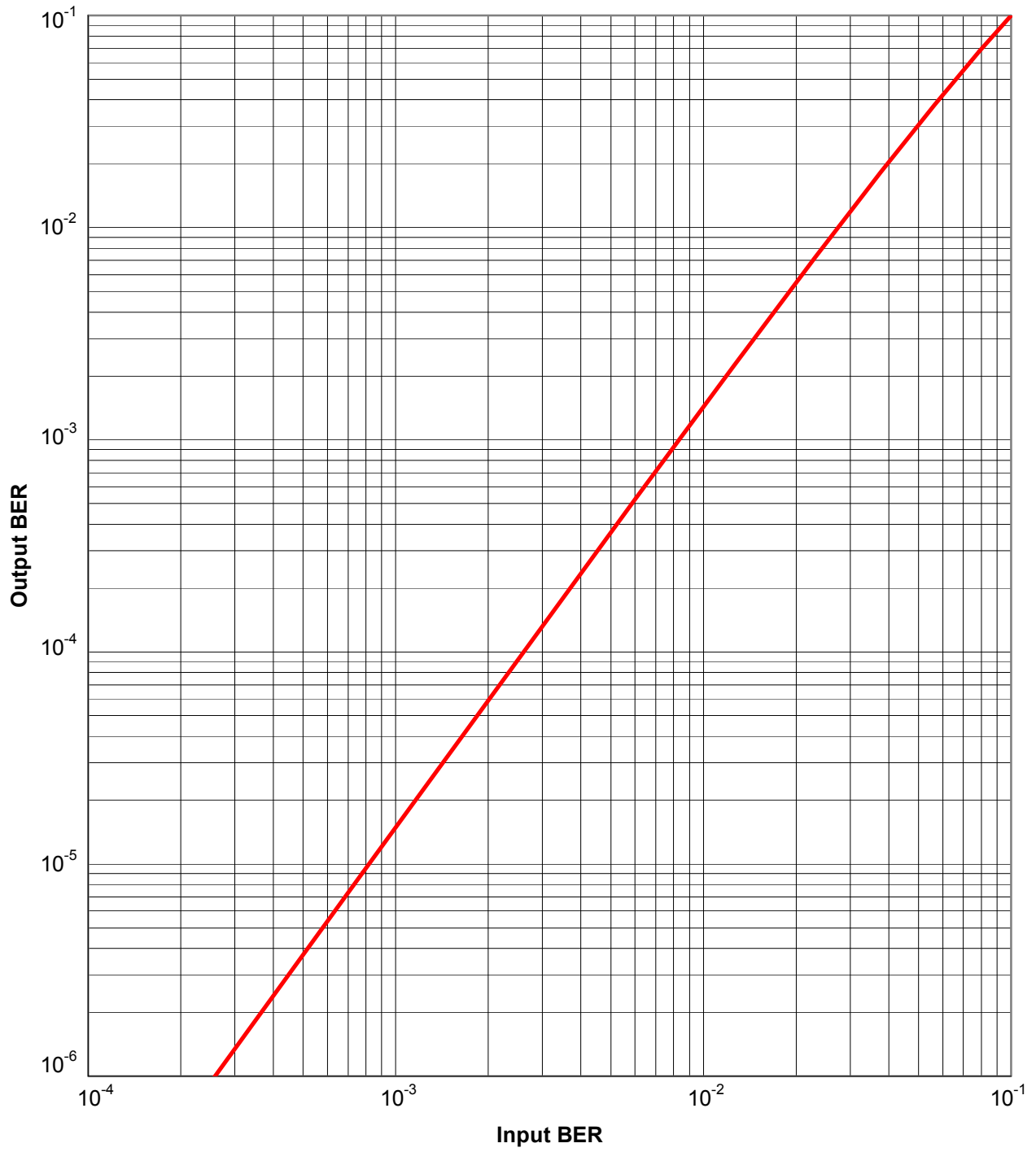

Figure 7.5-2. Output BER vs. Input BER Curve for Hard-decision (8, 4) Hamming Decoder

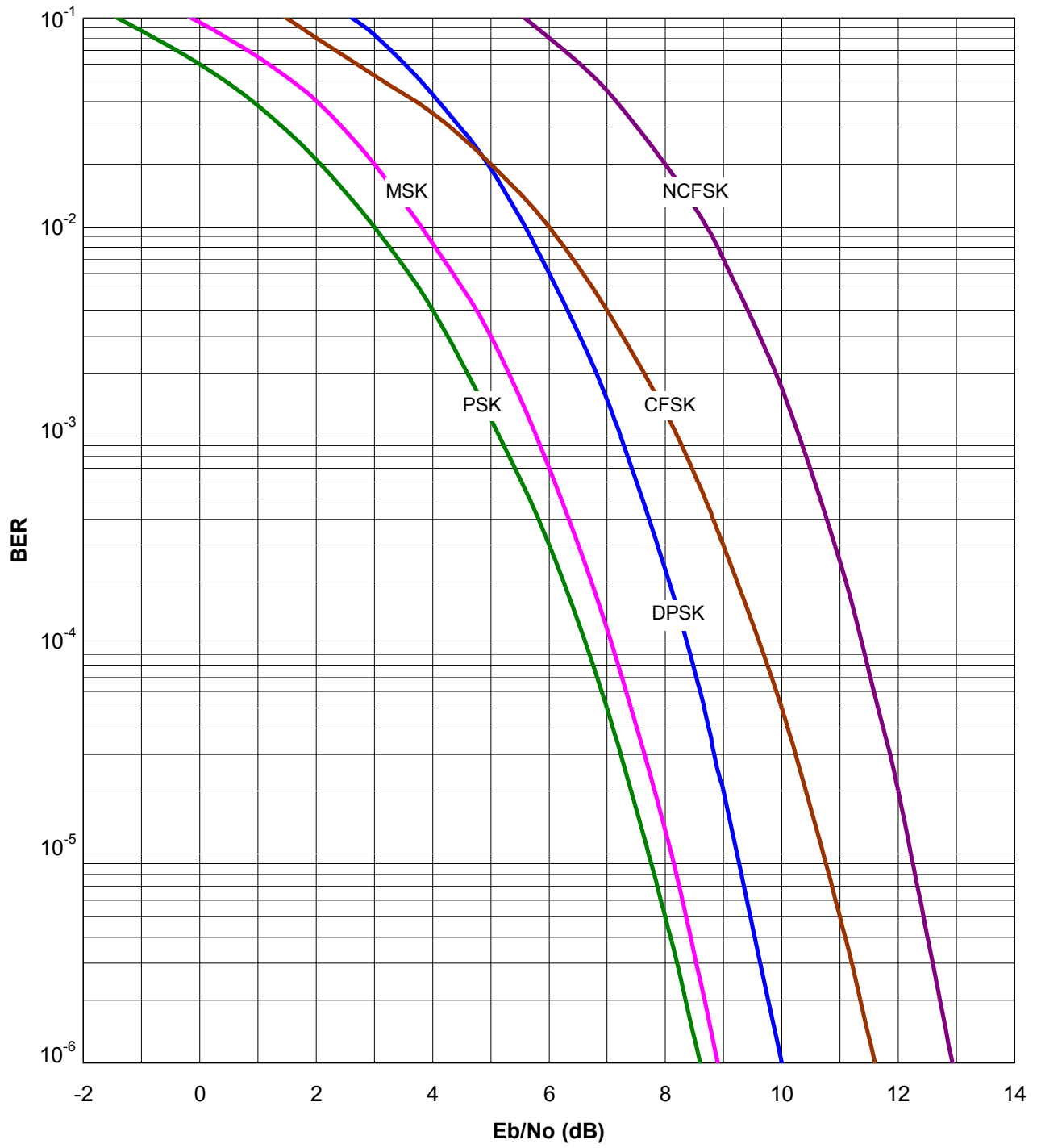

Figure 7.5-3. BER vs. E_b/N_o Curves for Soft-decision (8, 4) Hamming Decoder

Figure 7.5-4 shows the output BER vs. input BER curve for a hard-decision (64, 6) Hadamard decoder. The curve was generated by applying Equations 7-3 and 7-4. Figure 7.5-5 shows BER vs. E_b/N_o curves for a soft-decision (64, 6) Hadamard decoder and for various demodulator types. For these curves, the demodulator and FEC decoder are treated as one combined module.

7.5.6 Golay Code

The Golay code is an (n, k) block code with the following properties:

- $n = 23$
- $k = 12$
- $d = 7$
- $t = 3$

The Golay code is sometimes *extended* to (24, 12) by the addition of another redundancy bit. This does not affect the number of correctable errors, but it is more convenient for implementing a system with the code rate $R = 1/2$.

Figure 7.5-6 shows the output BER vs. input BER curve for a hard-decision extended (24, 12) Golay decoder. The curve was generated by applying Equations 7-3 and 7-4.

Figure 7.5-7 shows BER vs. E_b/N_o curves for a soft-decision extended (24, 12) Golay decoder and for various demodulator types. For these curves, the demodulator and FEC decoder are treated as one combined module.

7.5.7 Reed-Solomon Codes

In a Reed-Solomon (RS) encoder, the input bits are grouped to form *RS symbols* (not to be confused with *M*-ary demodulator symbols). Then the RS symbols are grouped into messages, and redundancy RS symbols are added to form code words. The code word length and the message length are expressed in terms of RS symbols rather than bits. RS codes have the following properties:

- $n = 2^m - 1$, where n is the number of RS symbols per code word and m is the number of bits per RS symbol
- $d = n - k + 1$, where d is the minimum distance measured in RS symbols and k is the number of RS symbols per message

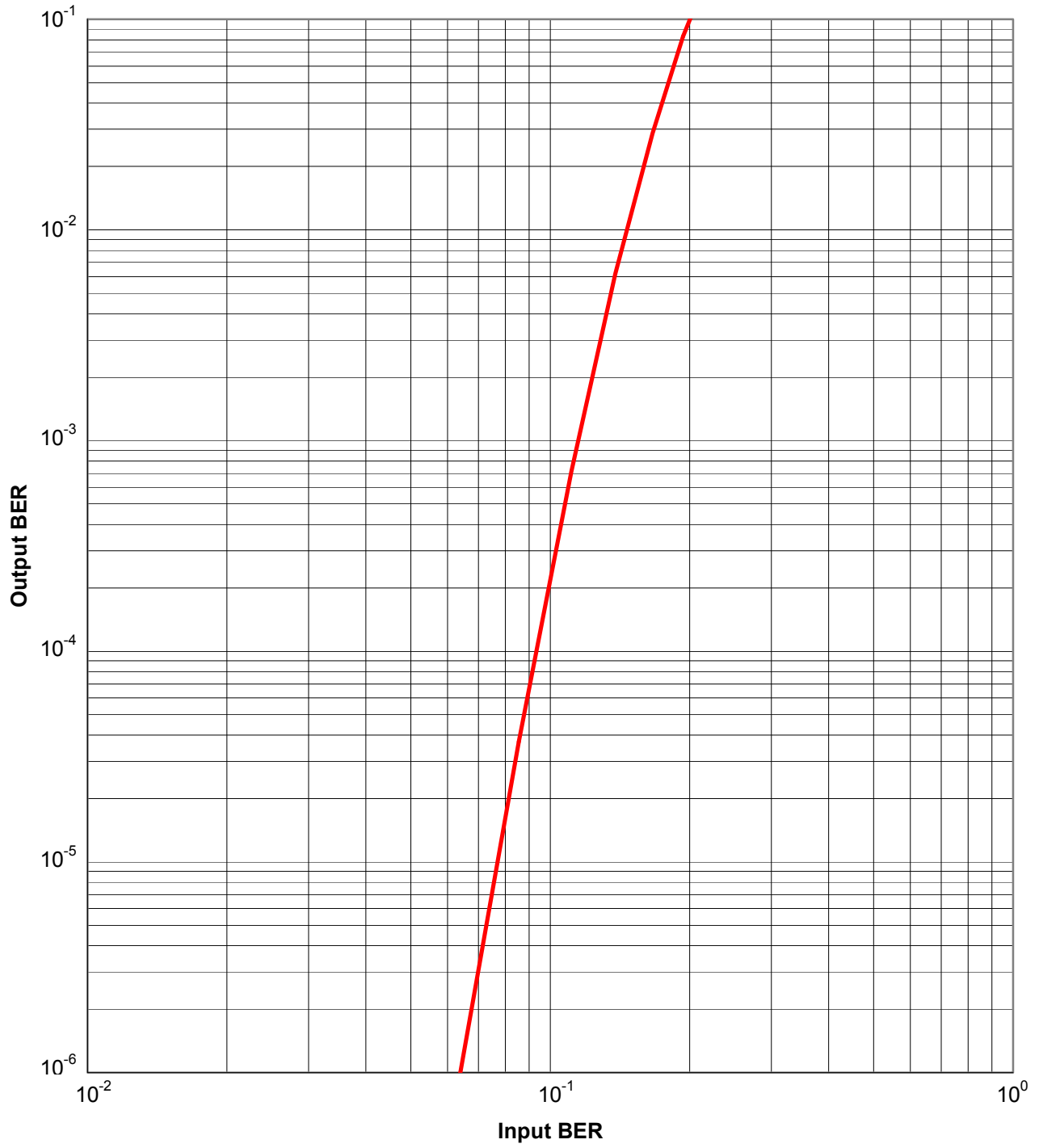

Figure 7.5-4. Output BER vs. Input BER Curve for Hard-decision (64, 6) Hadamard Decoder

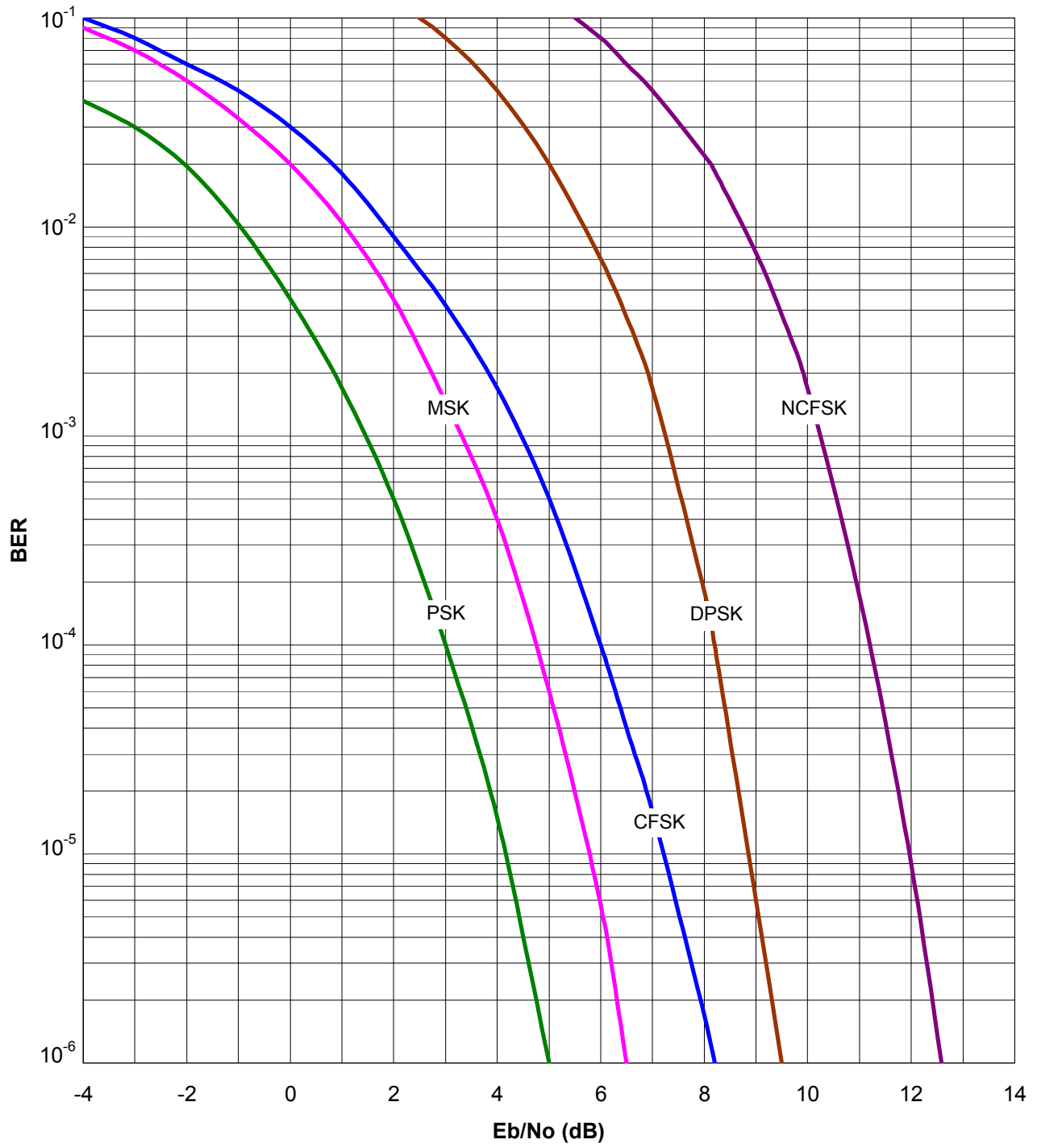

Figure 7.5-5. BER vs. E_b/N_o Curves for Soft-decision (64, 6) Hadamard Decoder

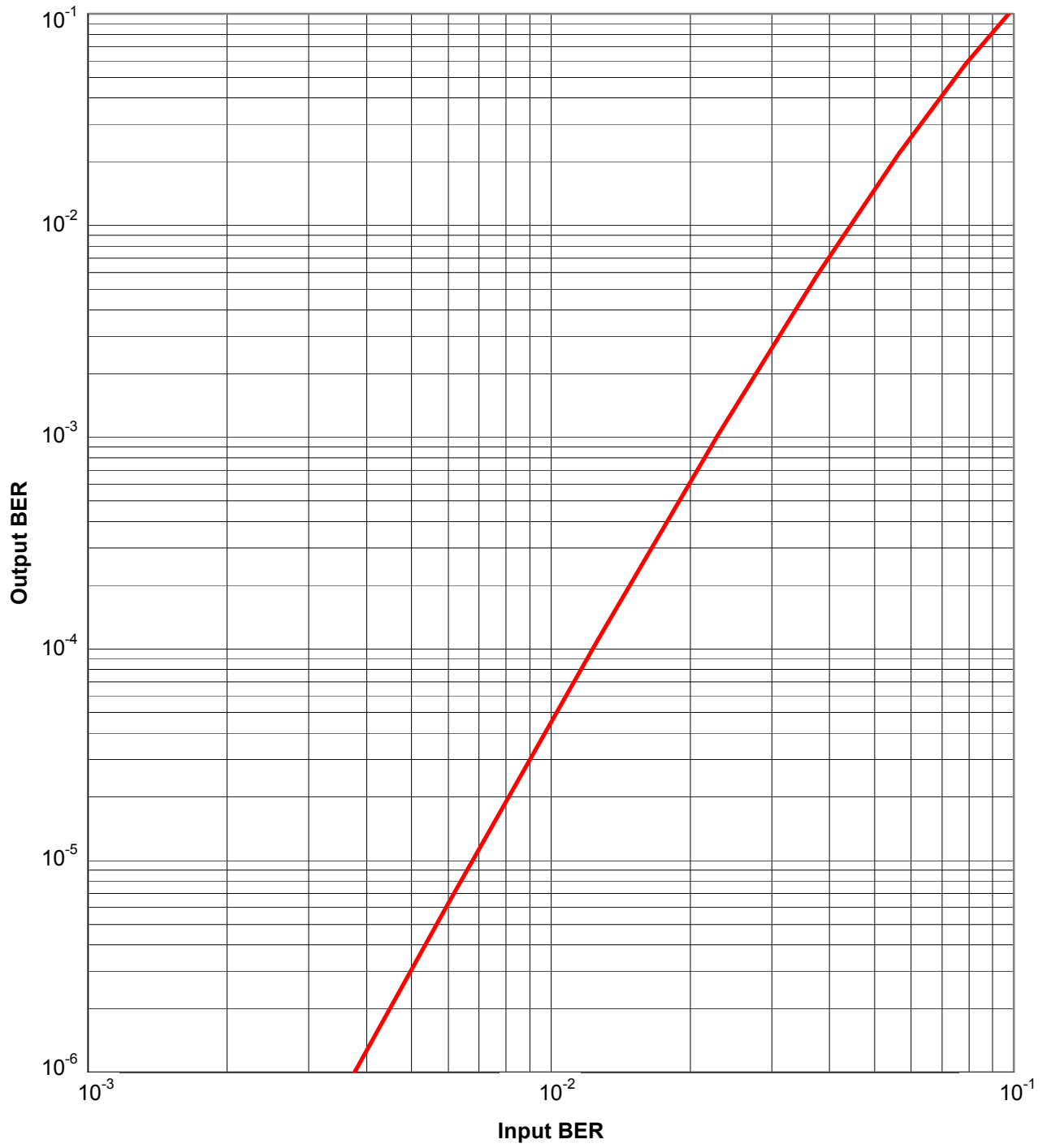

Figure 7.5-6. Output BER vs. Input BER Curve for Hard-decision (24, 12) Golay Decoder

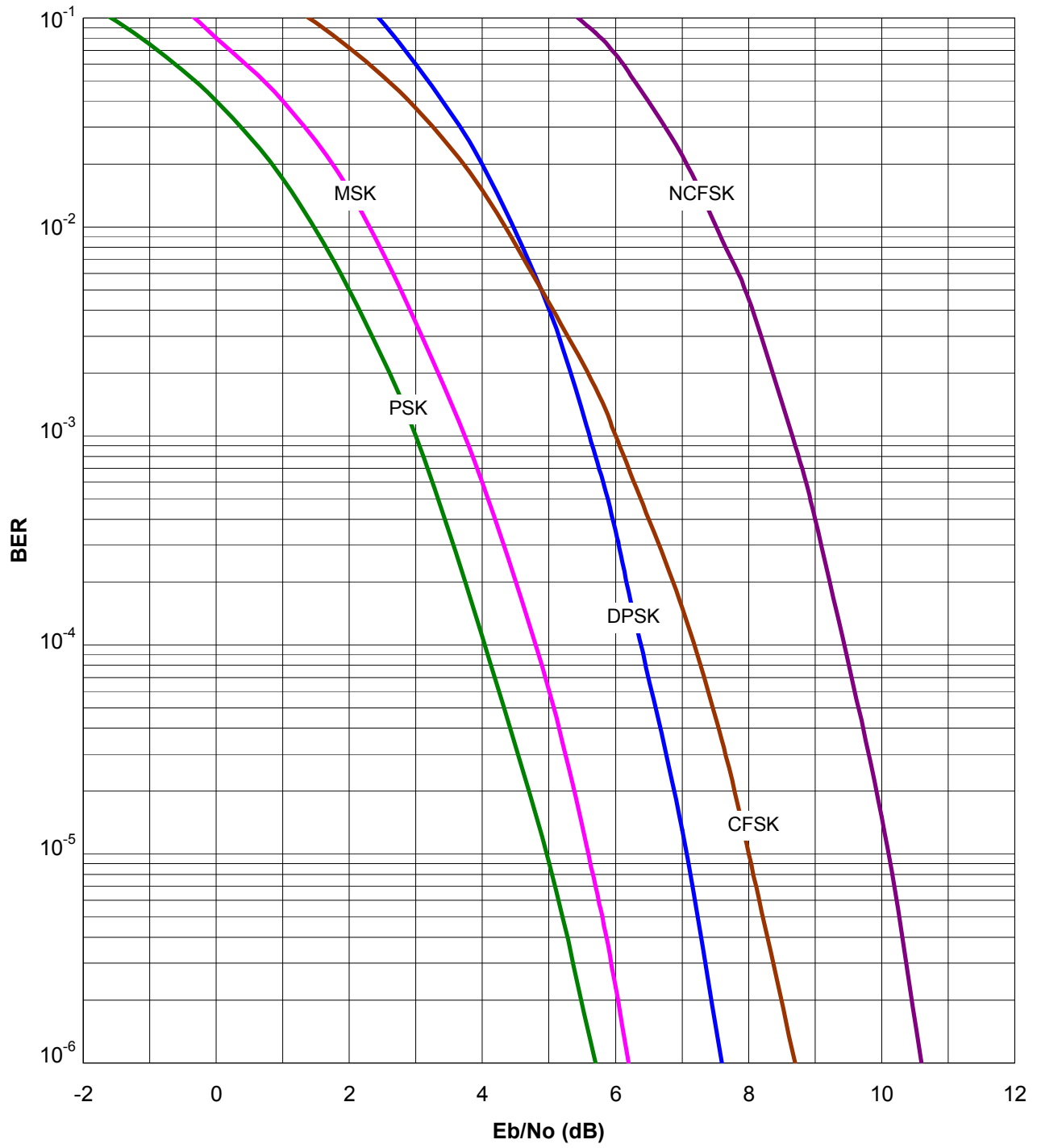

Figure 7.5-7. BER vs. E_b/N_o Curves for Soft-decision (24, 12) Golay Decoder

Equation 7-2 can still be used for RS codes, but d and t are expressed as numbers of RS symbols rather than bits. For example, a (15, 13) RS code has 4 bits per RS symbol, 13 RS symbols per message, and 15 RS symbols per code word. The minimum distance for the (15, 13) RS code is 3 RS symbols and the number of correctable RS symbols in a code word is 1.

The symbol-based structure of RS codes can be used to protect a system from burst errors, which are often caused by intermittent interference. For example, a (15, 13) RS code can correct one symbol per 15-symbol code word, regardless of the number of erroneous bits in the erroneous symbol.

Because a given RS symbol is formed by grouping m bits, it is correct only if all m bits are correct. Therefore, the RS SER is given by:

$$SER_{in} = 1 - (1 - BER_{in})^m \quad (7-5)$$

where

SER_{in} = RS symbol error rate at RS decoder input

BER_{in} = bit error rate at RS decoder input

Because the RS decoder operates on RS symbols rather than bits, Equation 7-3 is modified to show the dependency on RS SER:

$$WER = 1 - \sum_{j=0}^t \frac{n!}{(n-j)! j!} SER_{in}^j (1 - SER_{in})^{n-j} \quad (7-6)$$

Figure 7.5-8 shows the output BER vs. input BER curve for a hard-decision (255, 223) RS decoder. In this case, $m = 8$ and $t = 16$. The curve was generated by applying Equations 7-5 and 7-6.

Figure 7.5-9 shows BER curves for a (255, 223) RS coded PSK receiver ($M=4$) with on-tune broadband AWGN interference.

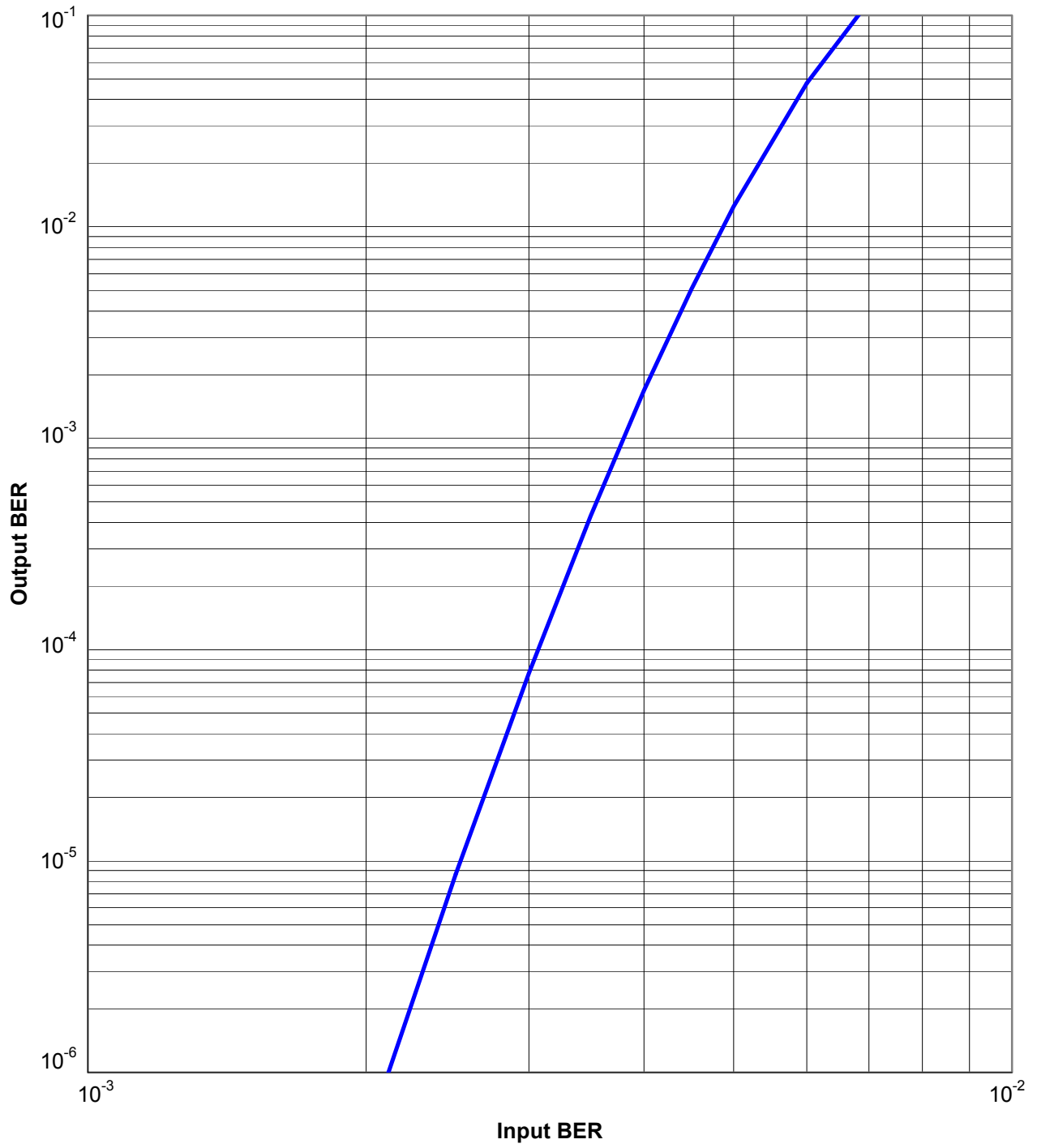

Figure 7.5-8. Output BER vs. Input BER Curve for Hard-decision (255, 223) RS Decoder

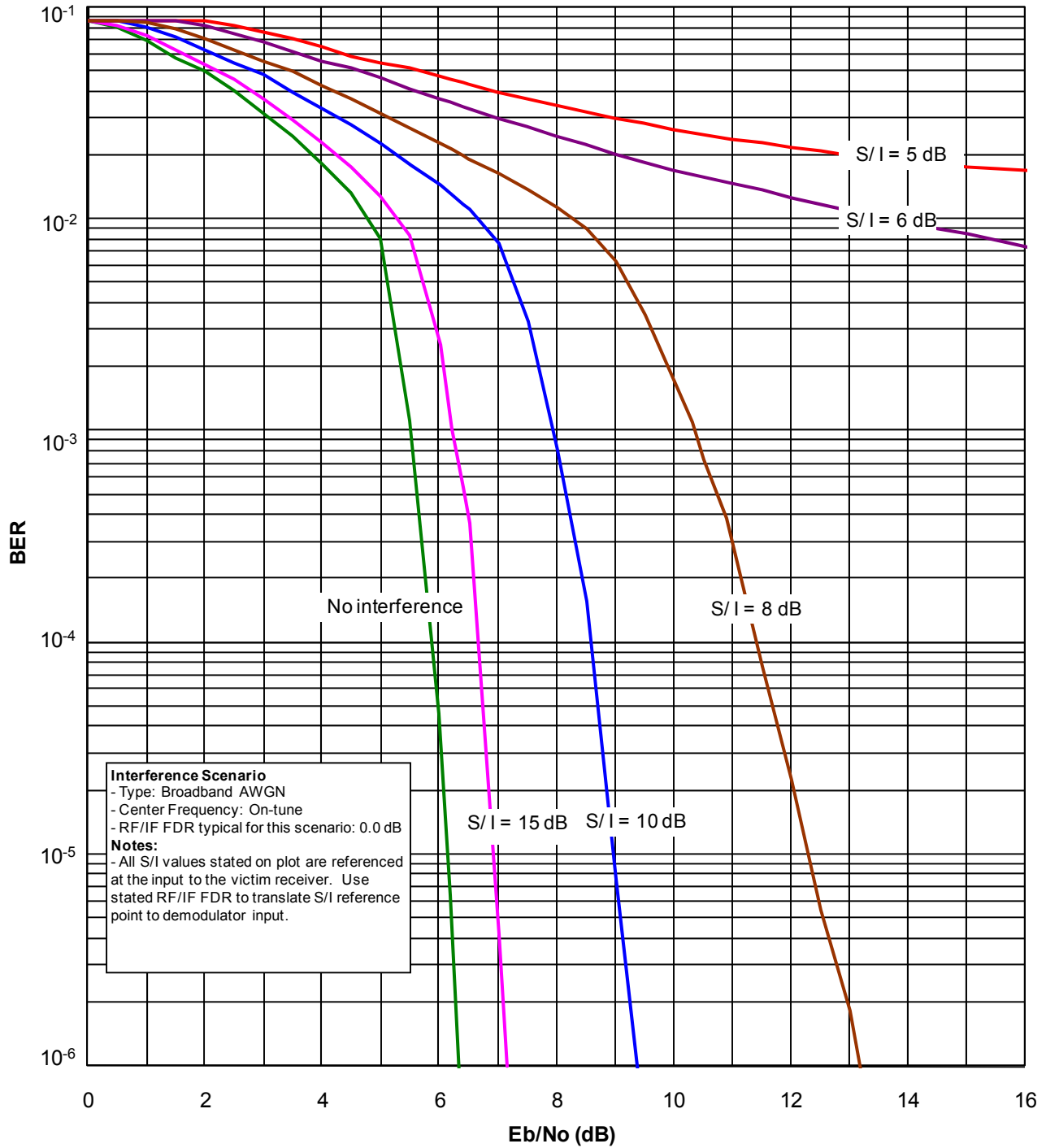

Figure 7.5-9. BER Curves vs. E_b/N_0 for (255, 223) RS Coded PSK Receiver ($M=4$) with On-Tune Broadband AWGN Interference

7.5.8 Turbo Product Codes

Turbo Product Code (TPC) encoding and decoding techniques are very briefly described here. A more detailed discussion of TPC can be found in technical literature. A product code is obtained from constituent (n_1, k_1) and (n_2, k_2) codes by filling an n_1 by n_2 rectangular array of coded bits with:

- a k_1 by k_2 rectangular array of information bits
- a k_1 by $(n_2 - k_2)$ rectangular array of parity bits computed by applying the (n_2, k_2) code's encoding rule to each of the k_1 rows of information bits
- an $(n_1 - k_1)$ by n_2 rectangular array of parity bits computed by applying the (n_1, k_1) code's encoding rule to each of the k_2 columns of information bits and $(n_2 - k_2)$ columns of parity bits computed in the previous step

This product code maps $k_1 k_2$ information bits into a total of $n_1 n_2$ coded bits. An identical product code results if the column encoding is done first and the row encoding second. Figure 7.5-10 shows construction of product code. A product code can be decoded iteratively by alternating the decoding of rows and columns, and passing soft extrinsic information between the row and column decoding in the manner of turbo decoding. A classic product code decoded in this manner is called a TPC.

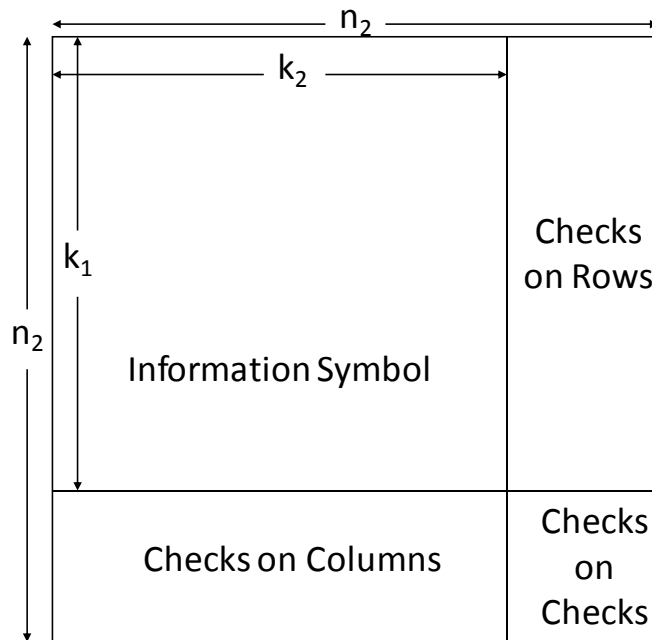

Figure 7.5-10. Construction of Product Code

Figure 7.5-11 shows BER curves for a $(64, 57)^2$ TPC PSK receiver ($M = 4$) with on-tune broadband AWGN interference.

Figure 7.5-12 shows BER curves for a $(64, 57)^2$ TPC PSK receiver ($M = 4$) with on-tune CW interference.

Figures 7.5-13, 7.5-14, and 7.5-15 show BER curves for a $(64, 57)^2$ TPC PSK receiver ($M=4$) with various on-tune pulsed interference scenarios (as annotated on the plots). Figures 7.5-16, 7.5-17, and 7.5-18 show BER curves for a $(64, 57)^2$ TPC PSK receiver ($M=4$) with various off-tune pulsed interference scenarios (as annotated on the plots).

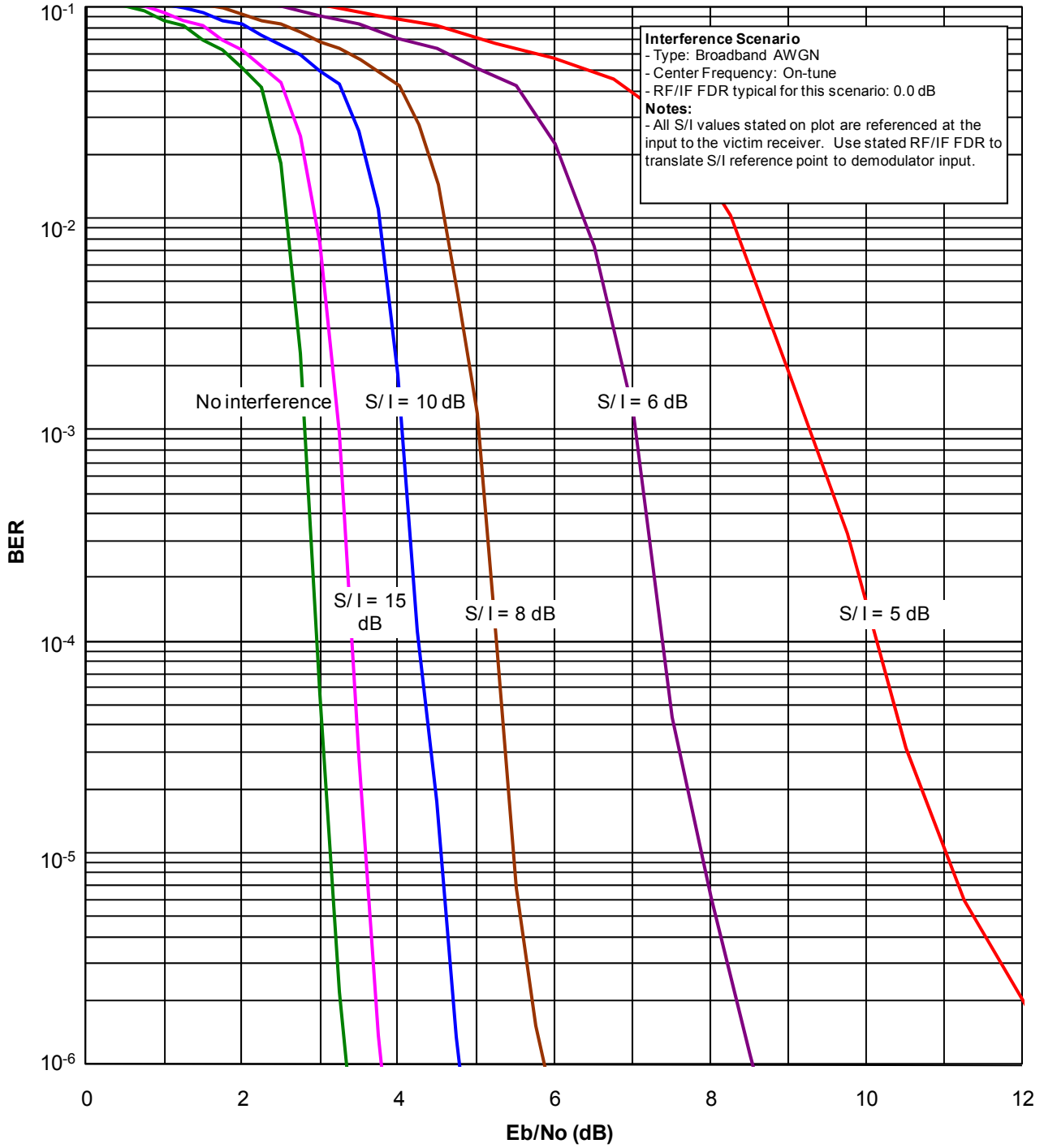

Figure 7.5-11. BER vs. E_b/N_0 Curves for $(64, 57)^2$ TPC PSK Receiver ($M = 4$) with On-Tune Broadband AWGN Interference

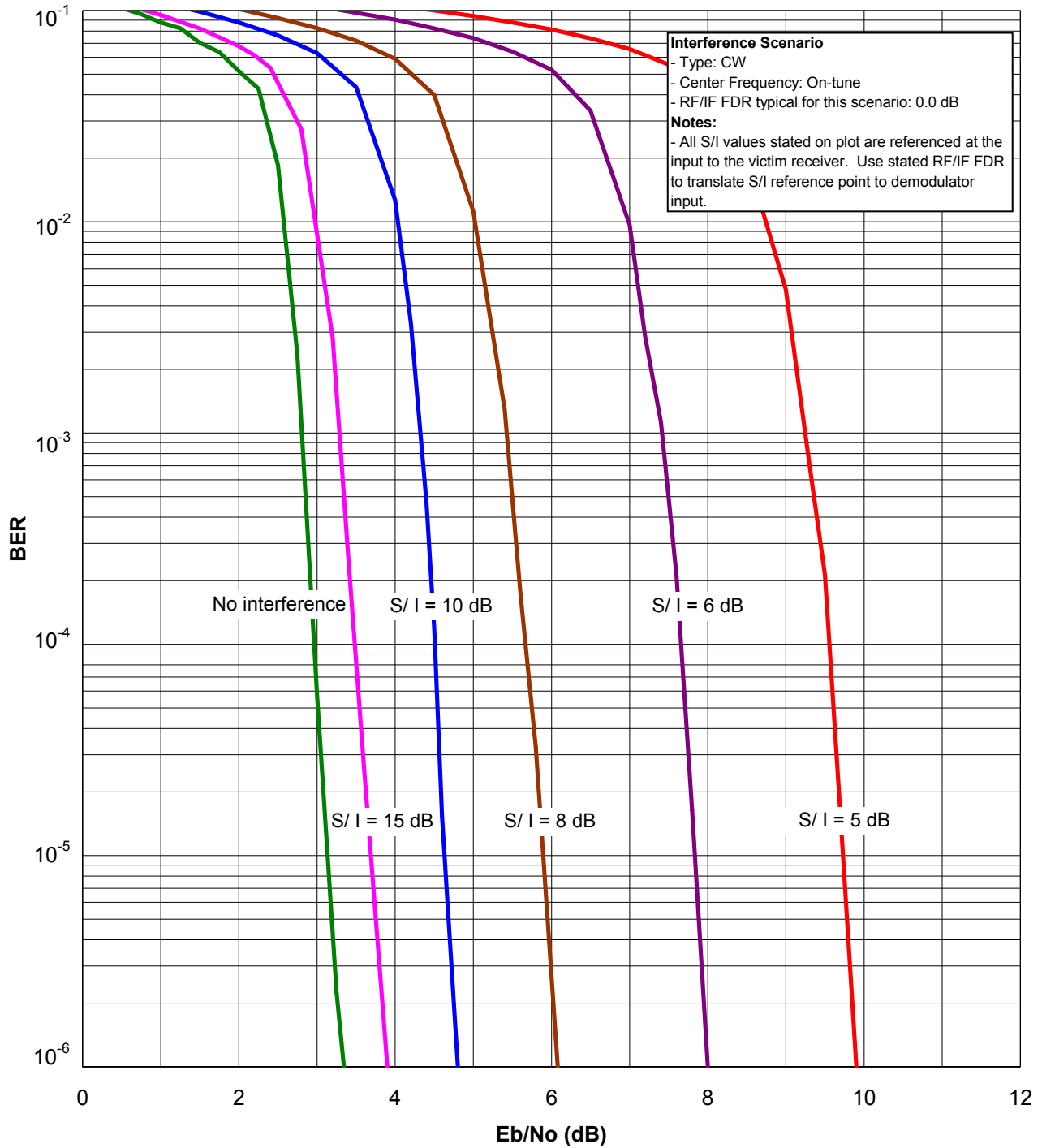

Figure 7.5-12. BER vs. E_b/N_o Curves for $(64, 57)^2$ TPC PSK Receiver ($M = 4$) with On-Tune CW Interference

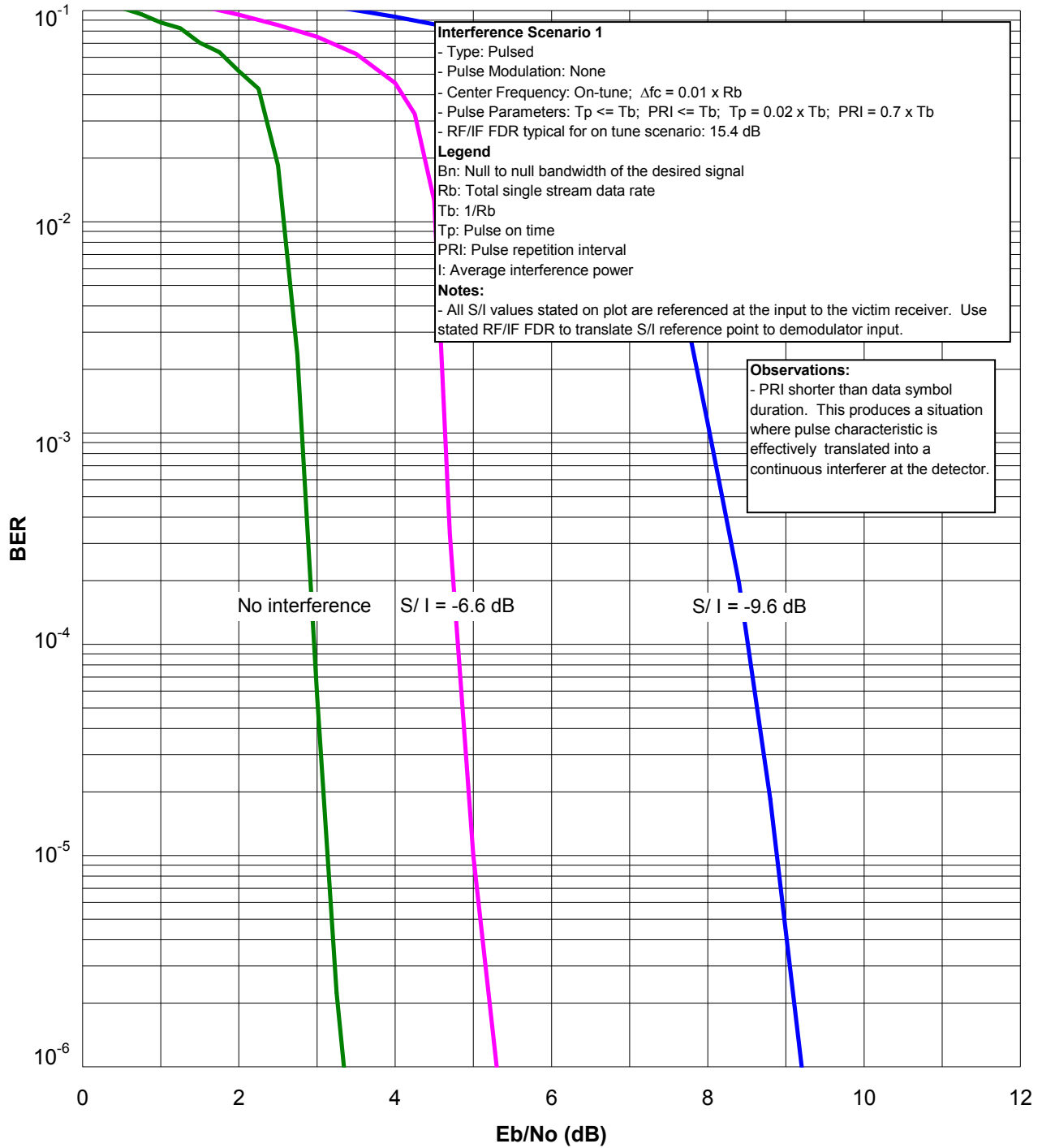

Figure 7.5-13. BER vs. E_b/N_0 Curves for $(64, 57)^2$ TPC PSK Receiver ($M = 4$) with On-Tune Pulsed Interference Scenario 1

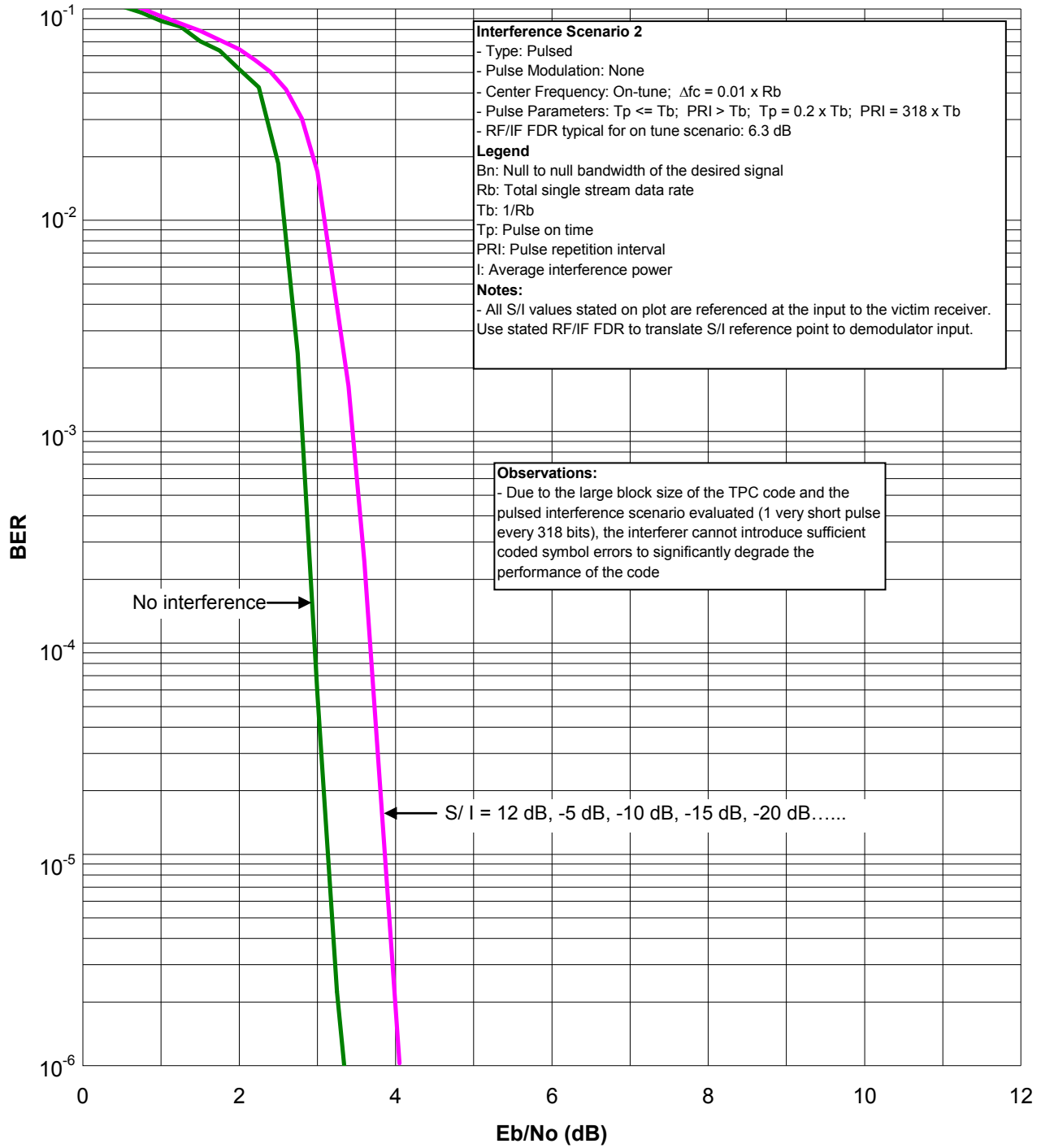

Figure 7.5-14. BER vs. E_b/N_o Curves for $(64, 57)^2$ TPC PSK Receiver ($M = 4$) with On-Tune Pulsed Interference Scenario 2

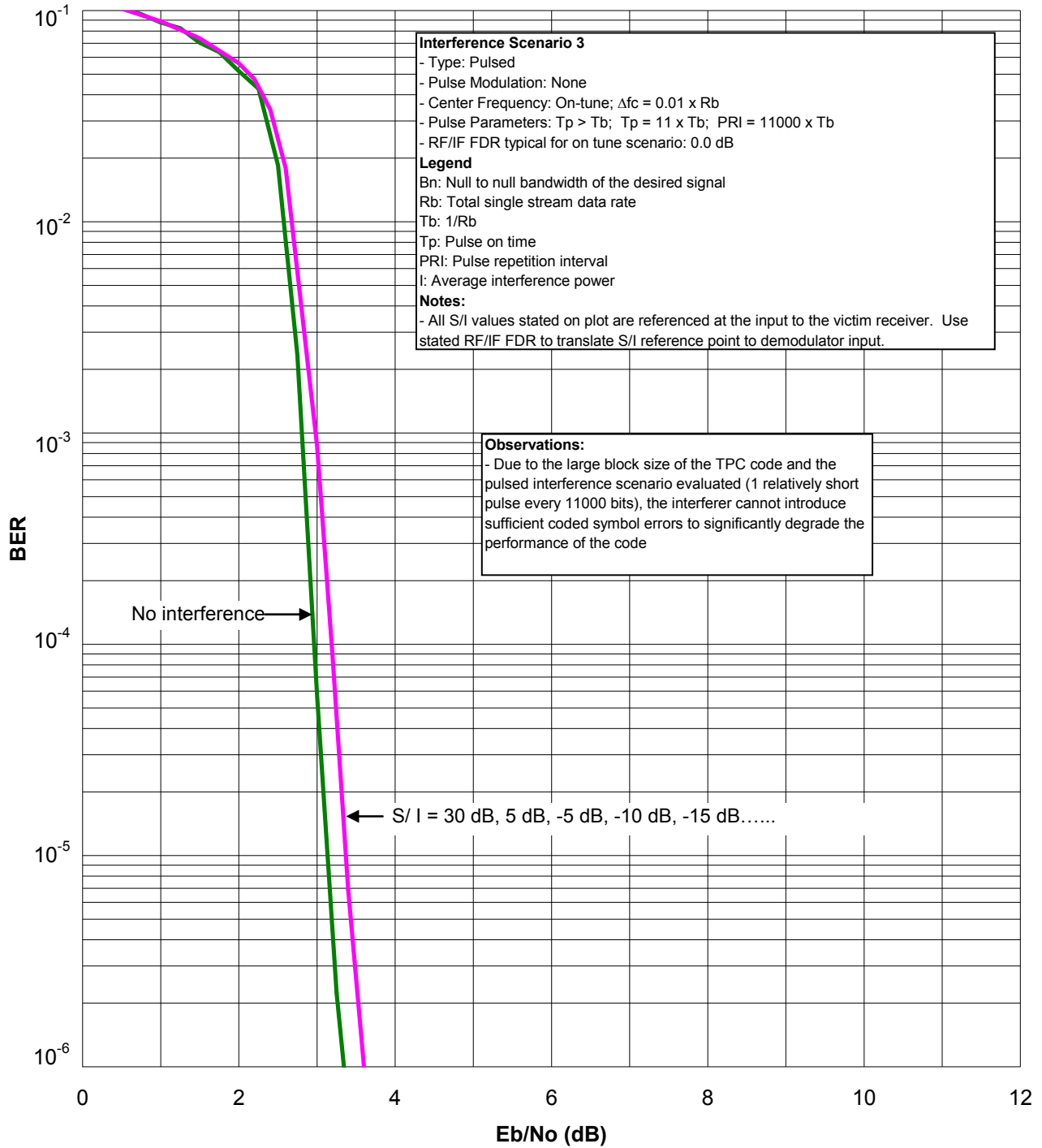

Figure 7.5-15. BER vs. E_b/N_o Curves for $(64, 57)^2$ TPC PSK Receiver ($M = 4$) with On-Tune and Pulsed Interference Scenario 3

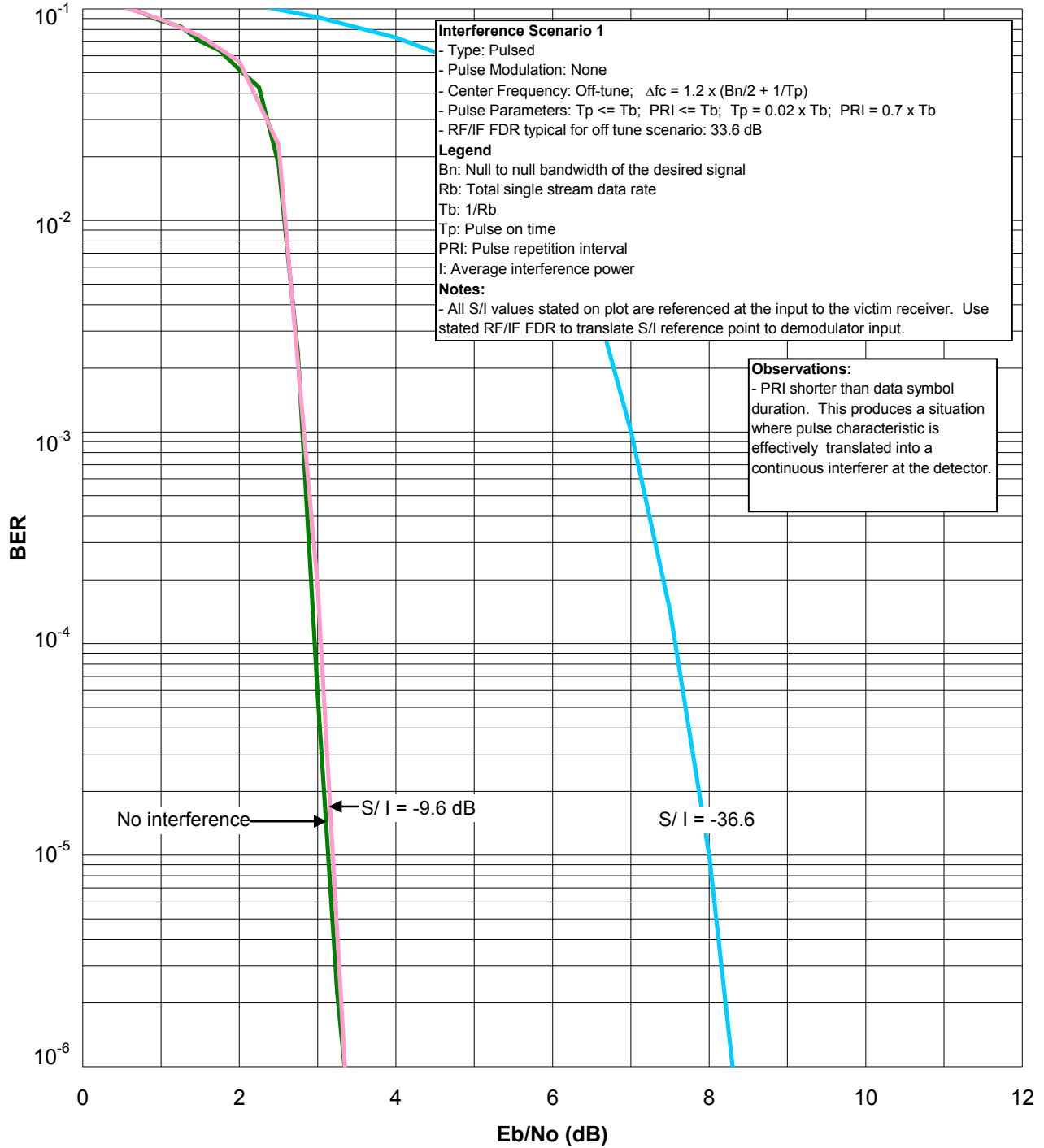

Figure 7.5-16. BER vs. E_b/N_o Curves for $(64, 57)^2$ TPC PSK Receiver ($M = 4$) with Off-Tune Pulsed Interference Scenario 1

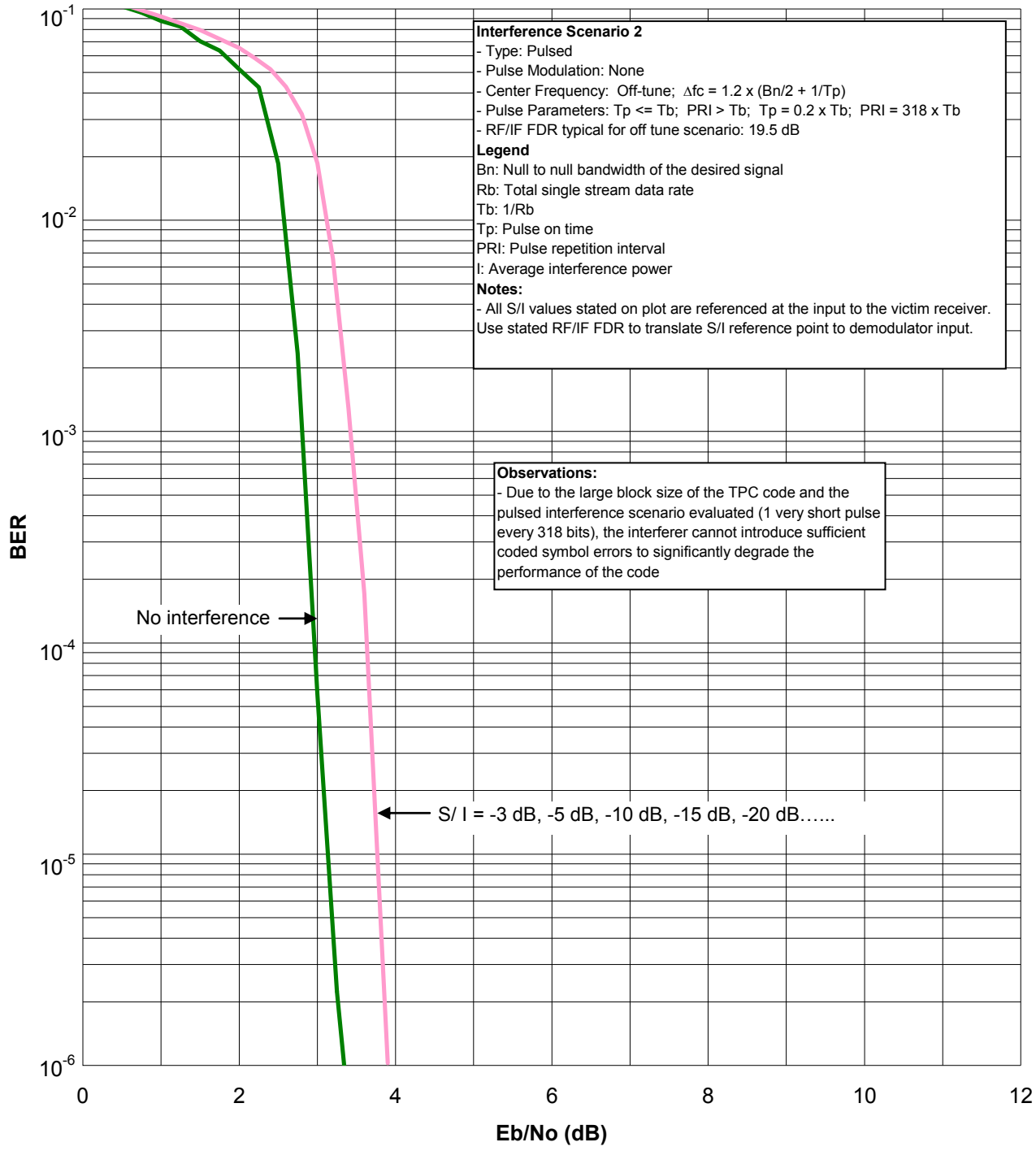

Figure 7.5-17. BER vs. E_b/N_o Curves for $(64, 57)^2$ TPC PSK Receiver ($M = 4$) with Off-Tune Pulsed Interference Scenario 2

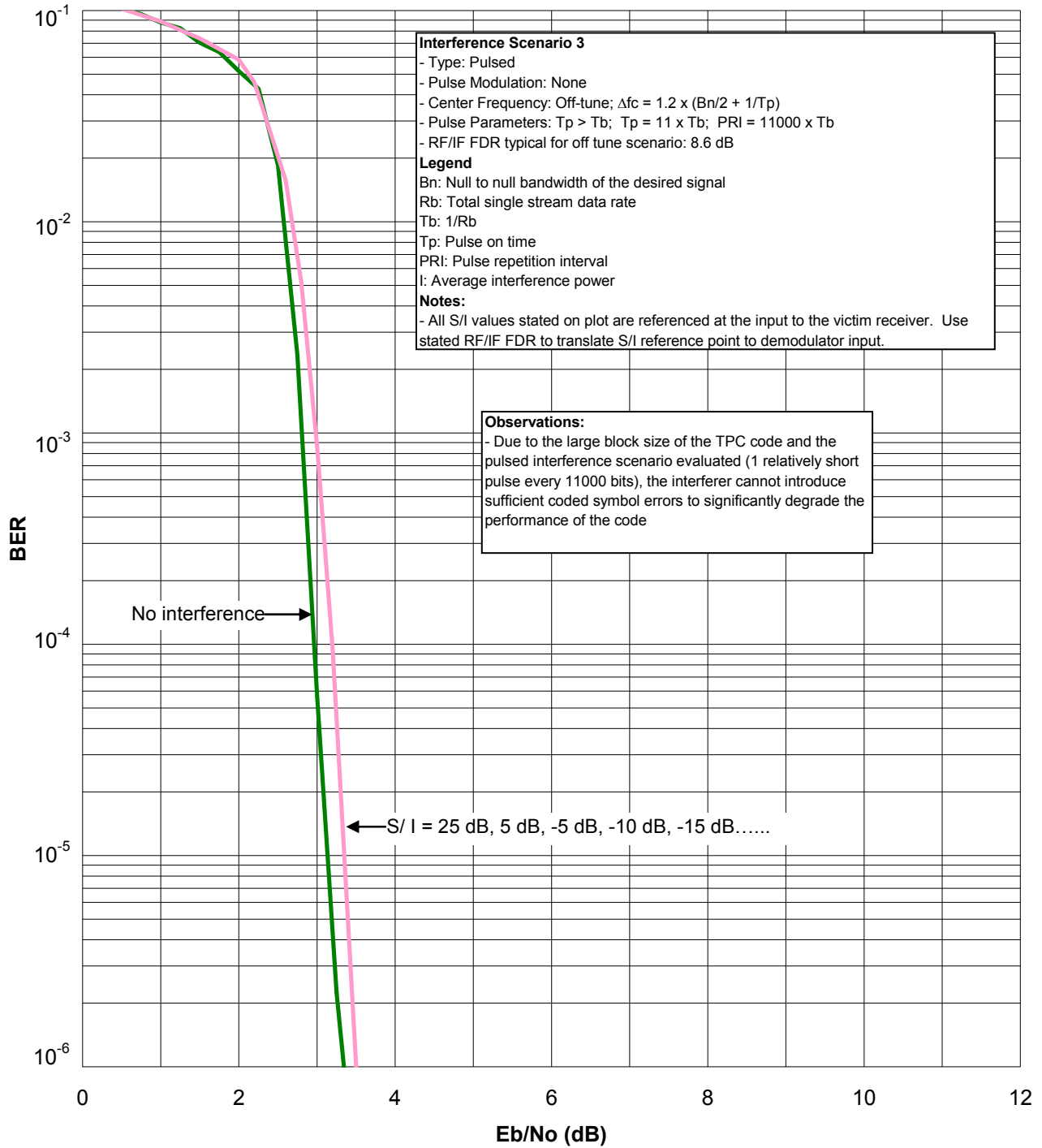

Figure 7.5-18. BER vs. E_b/N_o Curves for $(64, 57)^2$ TPC PSK Receiver ($M = 4$) with Off-Tune Pulsed Interference Scenario 3

7.5.9 Low Density Parity Check Codes

Low-Density Parity Check (LDPC) codes, also known as Gallager codes consists of block codes whose parity check matrix \mathbf{H} is sparse. Such a matrix consists of low-weight rows (ρ 1's) and columns (γ 1's) that make LDPC codes very suitable for iterative decoding. Besides turbo codes, LDPC codes form another class of Shannon limit-approaching codes. LDPC coding and decoding techniques are briefly discussed here. A low-density parity check matrix is usually very large and both ρ and γ are small compared with the code length and the number of rows in the matrix. The parity check matrix defined below illustrates a (8, 4) code with $\rho = 4$ (minimum weight per row) and $\gamma = 2$ (minimum weight per column).

$$H = \begin{bmatrix} 0 & 1 & 0 & 1 & 1 & 0 & 0 & 1 \\ 1 & 1 & 1 & 0 & 0 & 1 & 0 & 0 \\ 0 & 0 & 1 & 0 & 1 & 1 & 1 & 0 \\ 1 & 0 & 0 & 1 & 0 & 0 & 1 & 1 \end{bmatrix}$$

Note that this Parity Check Matrix \mathbf{H} is very small to be described as low-density, it is shown here as a matrix example. It is common to represent linear codes by graphs. Such representation provides not only a complete representation of the structure of the code, but it also helps to describe the decoding algorithm which is commonly based on belief propagation. A Tanner graph is a bipartite graph and is typically used to display the incidence relationship between the code bits of the code and the parity-check sums that check on them. It consists of m check nodes (number of parity bits) and n variable nodes (number of bits in a code word). Check node f_i is connected to variable node c_j if the element h_{ij} of \mathbf{H} is a 1. Figure 7.5-19 illustrates the Tanner graph corresponding to the parity check matrix \mathbf{H} .

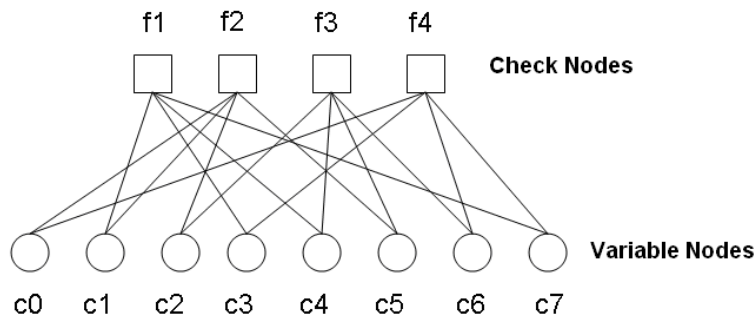

Figure 7.5-19. Tanner Graph Corresponding to the Parity Check Matrix H

LDPC codes are positioned to become a standard in the developing market for highly efficient data transmission methods. It was adopted to be the error correcting code in the Direct Video Broadcast Standard-2 (DVB-S2) for the satellite transmission of digital television.

Decoding of LDPC Codes

The most popular way to decode an LDPC code is by using iterative decoding based on belief propagation (also known as sum-product algorithm). The term “belief propagation” comes from the fact that the belief about symbol values propagates through the code based on the graph structure.

The algorithm alternately operates over the check nodes and variable nodes to find the most likely code vector that satisfies the condition $\mathbf{cH}^T = 0$. The algorithm¹⁹ works roughly the following way: the variable nodes send their messages to the check nodes which, in turn, calculate their response messages. The algorithm will stop if the current estimate code word fulfills the parity check equations. Otherwise, their response messages are sent back to the variable nodes for more iteration.

The following BER curves are based on the DVB-S2.

Figure 7.5-20 shows BER curves for an LDPC coded PSK receiver ($M = 4$) with on-tune broadband AWGN interference. Figure 7.5-21 shows BER curves for an LDPC coded PSK receiver ($M = 4$) with on-tune CW interference. Figures 7.5-22, 7.5-23, and 7.5-24 show BER curves for an LDPC coded PSK receiver ($M = 4$) with various on-tune pulsed interference scenarios (as annotated on the plots). Figures 7.5-25 and 7.5-26 show BER curves for an LDPC coded PSK receiver ($M = 4$) with various off-tune pulsed interference scenarios (as annotated on the plots).

¹⁹ S. Lin, D. Costello. *Error Control Coding*. Prentice Hall, 2nd Ed. 2004.

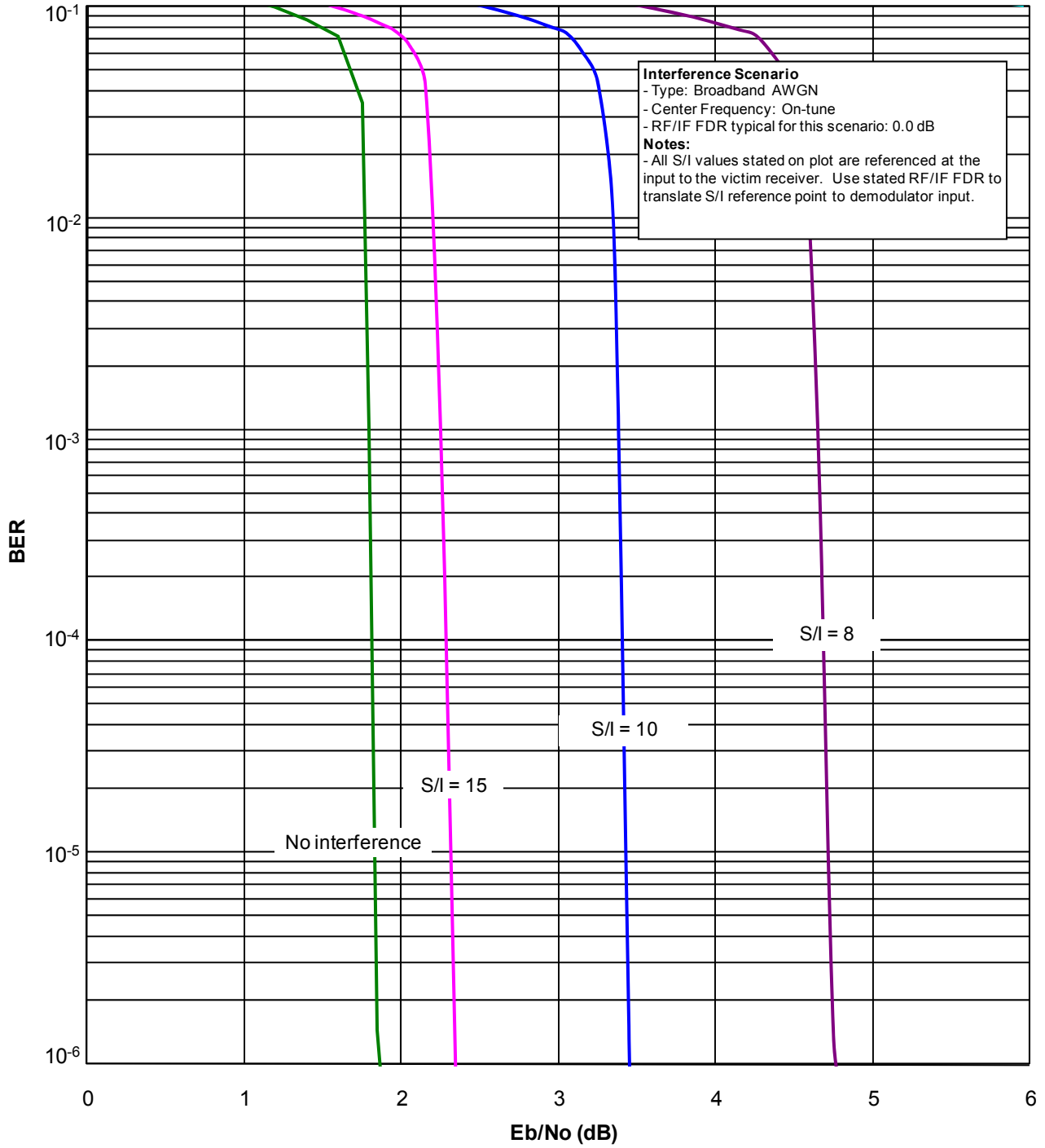

Figure 7.5-20. BER vs. E_b/N_o Curves for a (64800, 32400) LDPC coded PSK Receiver ($M = 4$) with On-Tune Broadband AWGN Interference

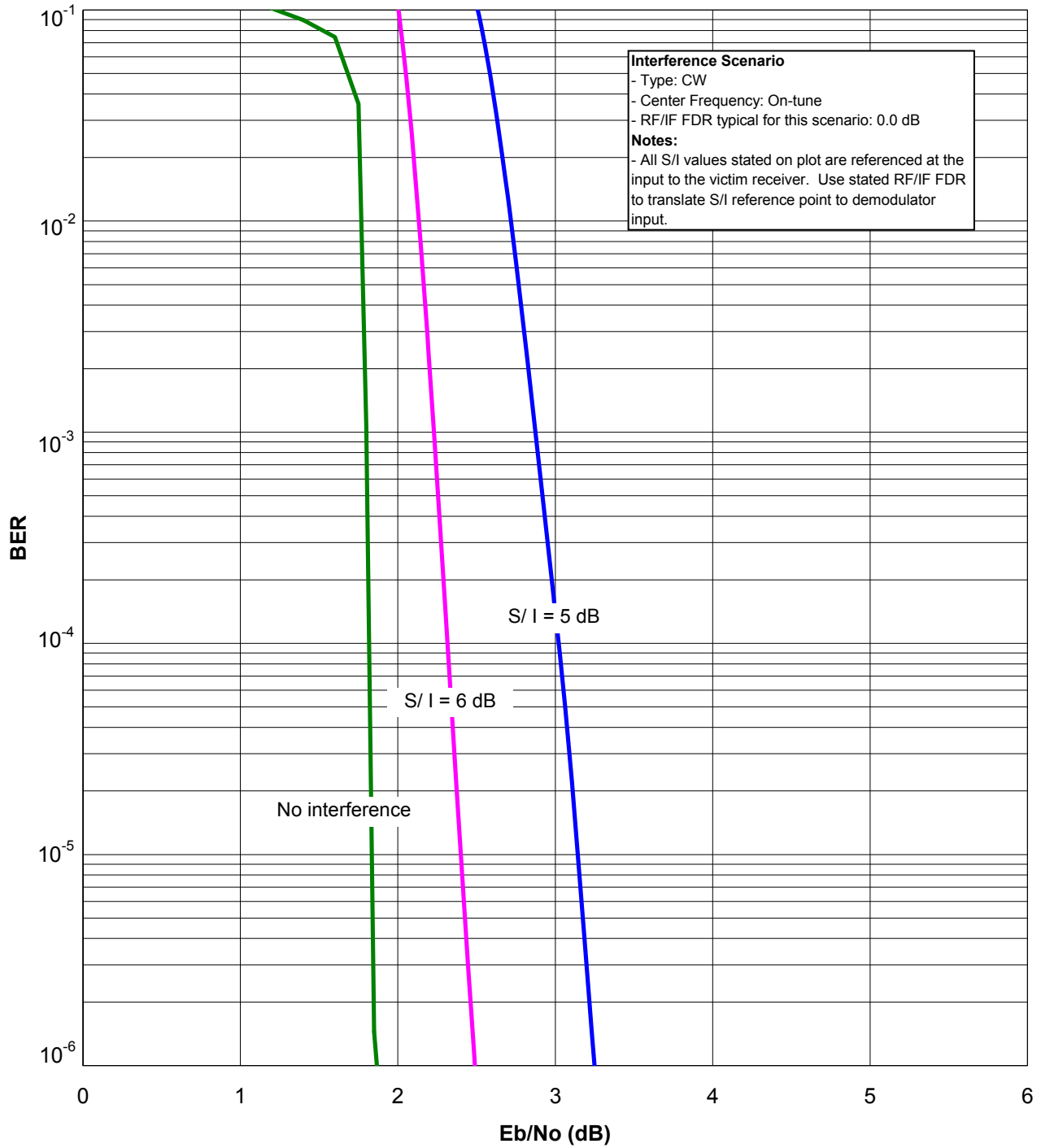

Figure 7.5-21. BER vs. E_b/N_o Curves for a (64800, 32400) LDPC coded PSK Receiver ($M = 4$) with On-Tune CW Interference

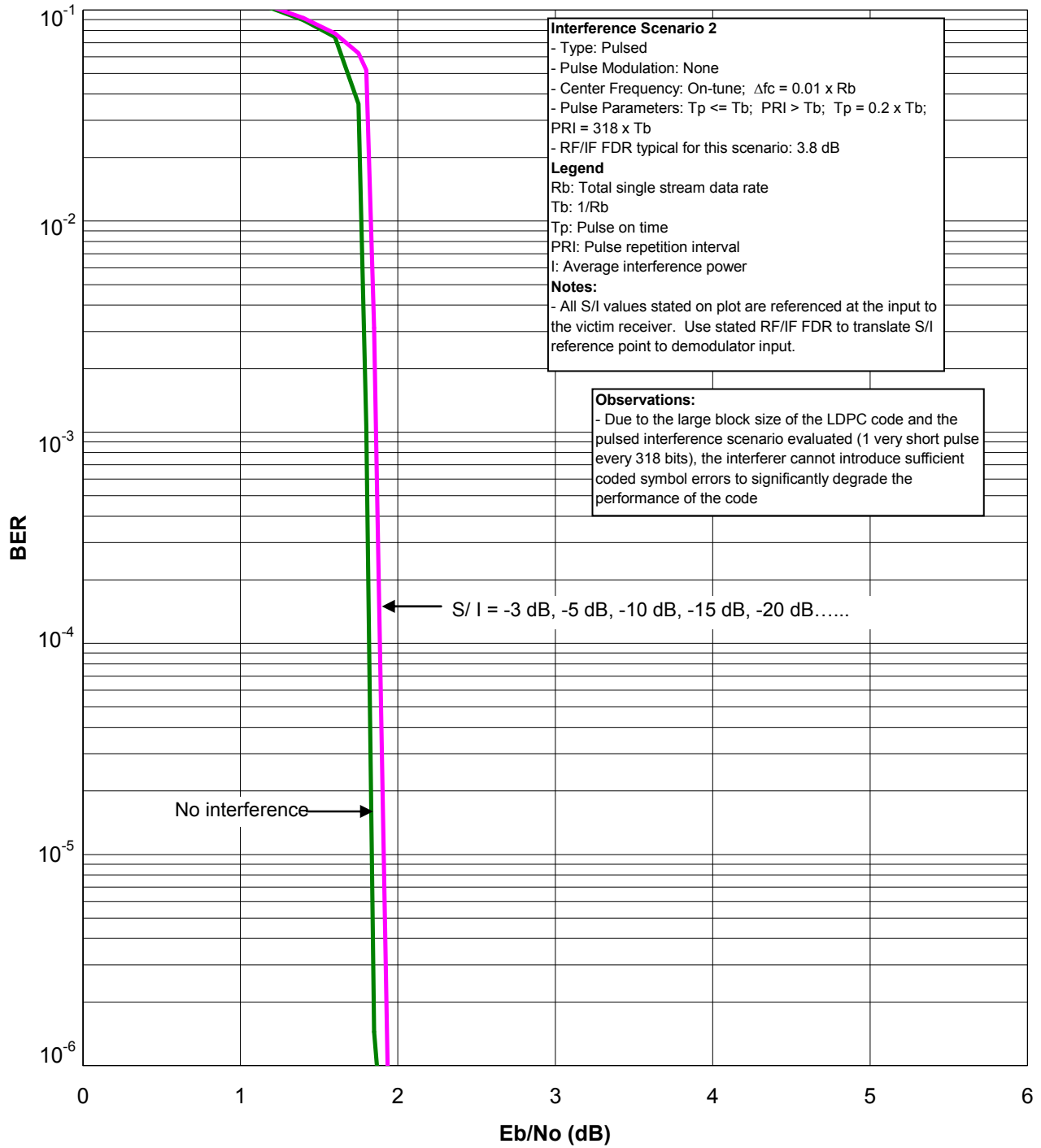

Figure 7.5-22. BER vs. E_b/N_o Curves for a (64800, 32400) LDPC coded PSK Receiver ($M = 4$) with On-Tune Pulsed Interference Scenario 2

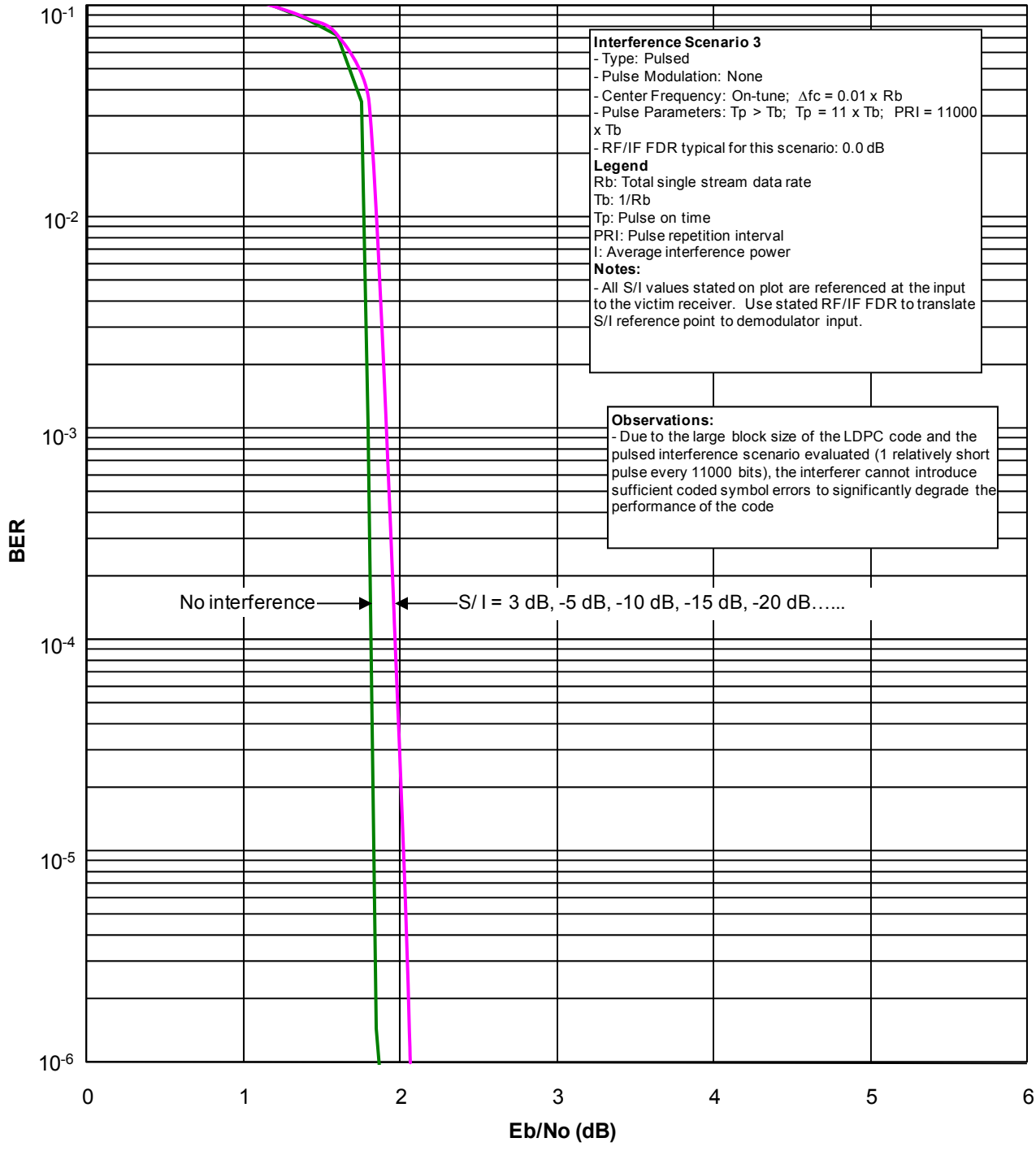

Figure 7.5-23. BER vs. E_b/N_o Curves for a (64800, 32400) LDPC coded PSK Receiver ($M = 4$) with On-Tune Pulsed Interference Scenario 3

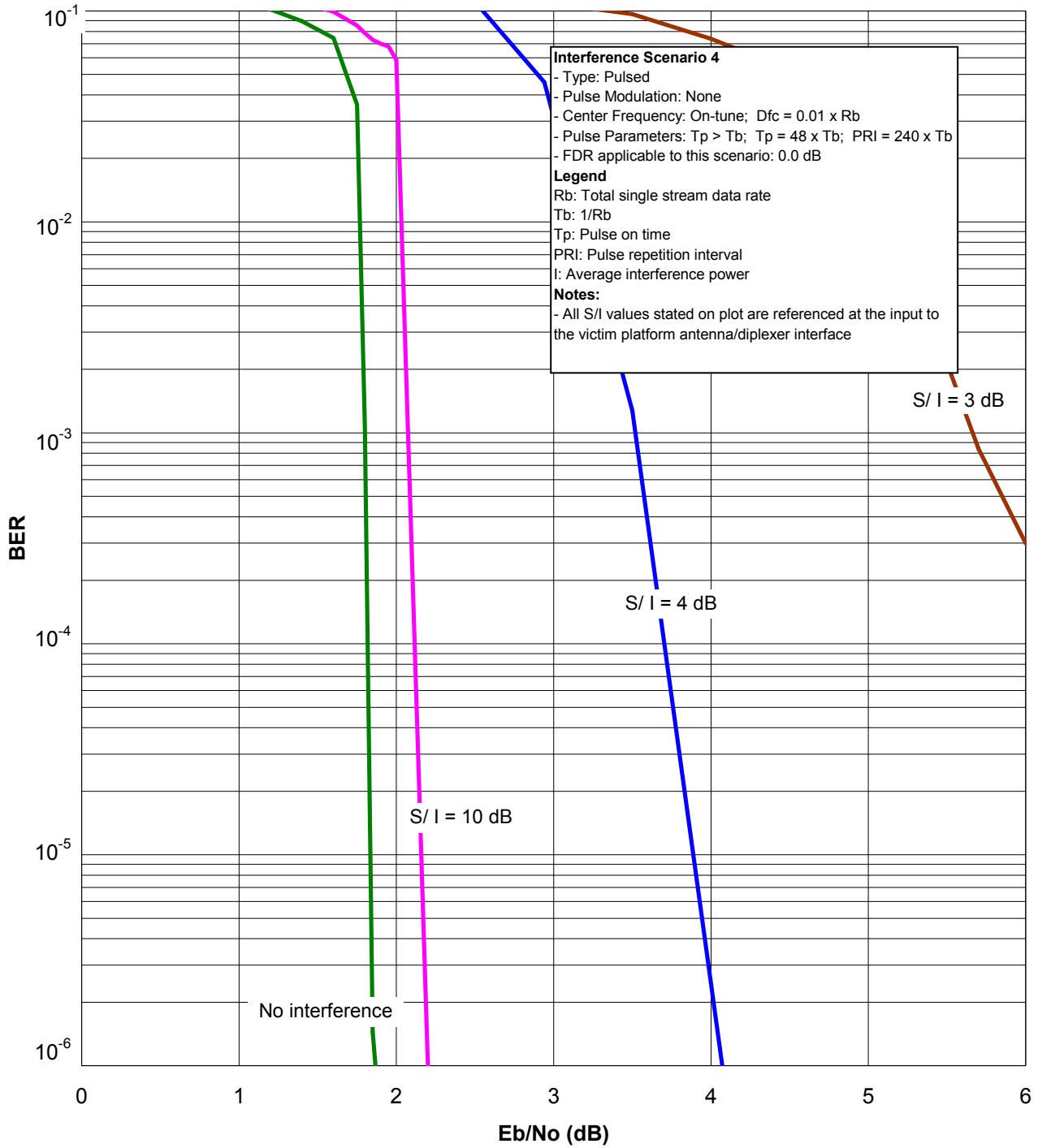

Figure 7.5-24. BER vs. E_b/N_0 Curves for a (64800, 32400) LDPC coded PSK Receiver ($M = 4$) with On-Tune Pulsed Interference Scenario 4

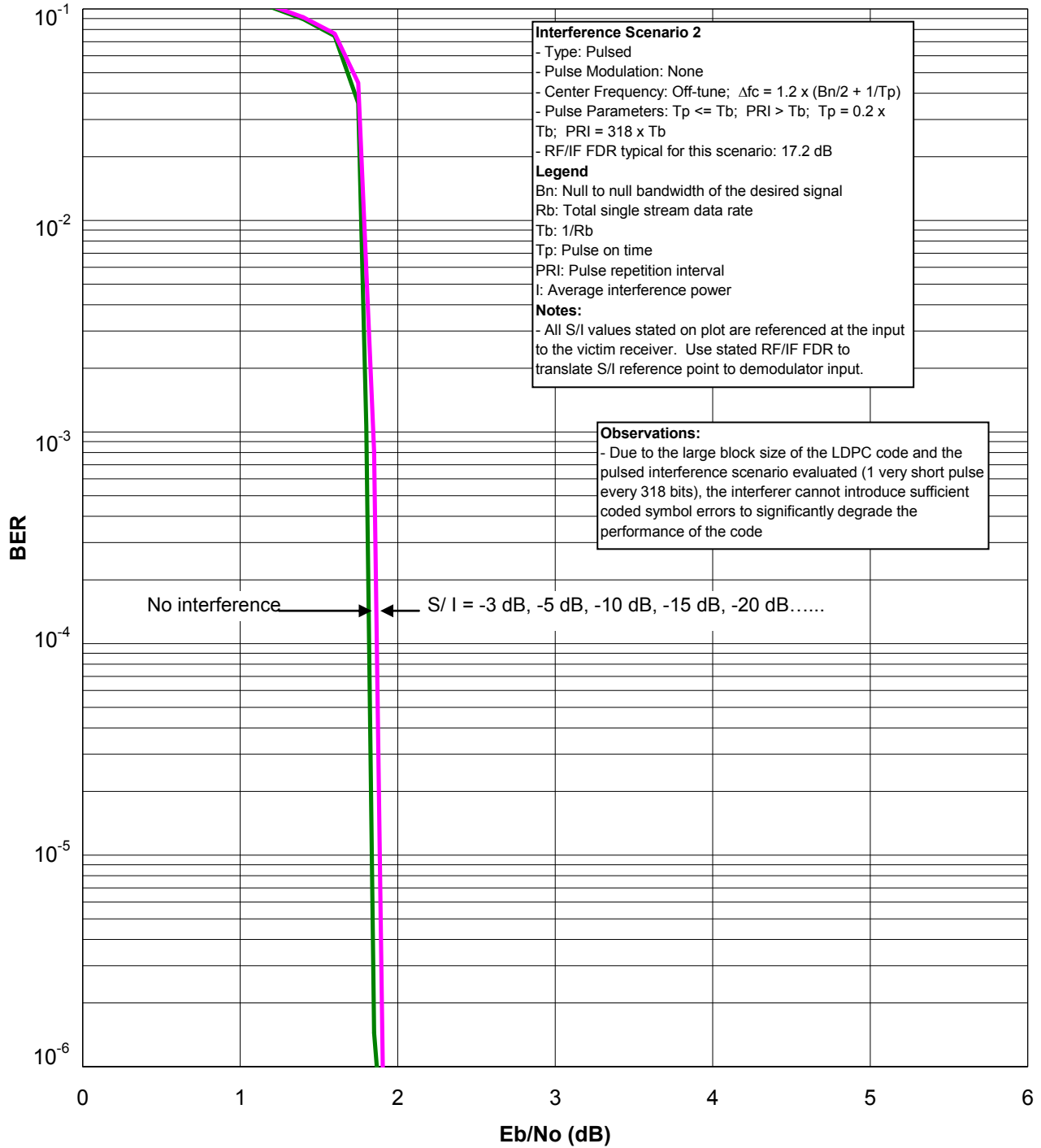

Figure 7.5-25. BER vs. E_b/N_o Curves for a (64800, 32400) LDPC coded PSK Receiver ($M = 4$) with Off-Tune Pulsed Interference Scenario 2

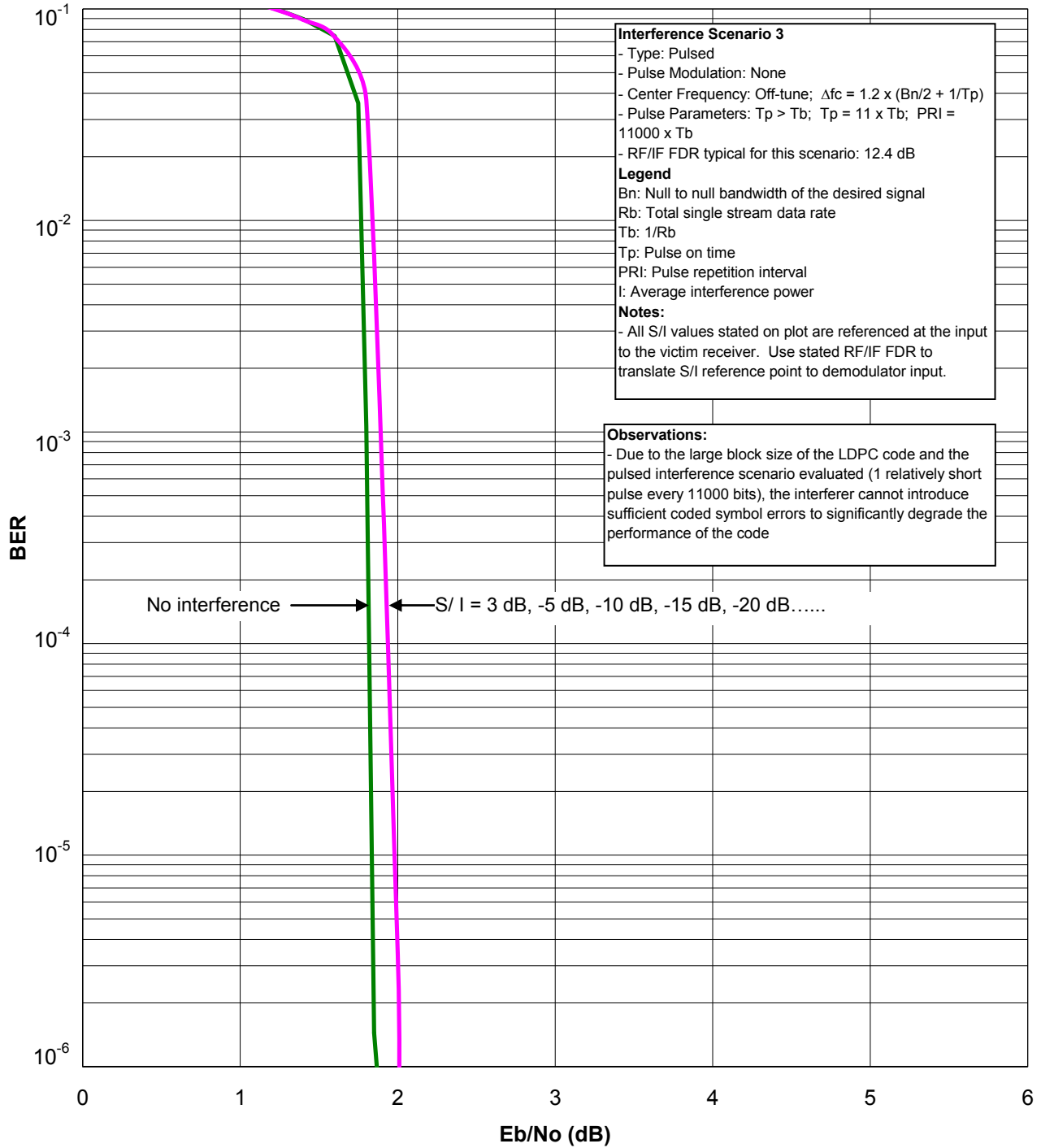

Figure 7.5-26. BER vs. E_b/N_o Curves for a (64800, 32400) LDPC coded PSK Receiver ($M = 4$) with Off-Tune Pulsed Interference Scenario 3

7.5.10 Interleaving

Every FEC block code has the ability to correct t erroneous bits per n -bit code word. If a code word has more than t erroneous bits, the code word is decoded incorrectly. Such a code is very effective at protecting against the occasional random errors that result from noise and noise like interference. Intermittent interference, which can be modeled as a sequence of pulses, is another matter. Intermittent interference often results in a very high bit-error probability during a pulse. If the pulse duration T_i is long enough that it can corrupt more than t bits in a particular code word, the FEC decoder will be unable to correct the errors. This will occur when $T_i > tT_b$, a condition referred to as overloading.

Figures 7.5-27 and 7.5-28 illustrate pulsed interference to a digital system.

Figure 7.5-27 illustrates overloading for a sequence of four code words (W_1, W_2, W_3, W_4), assumed to be part of a longer transmission for a system using a (7, 4) code. This code can correct one bit error per code word. Because the interference pulse is longer than one bit, the decoder is overloaded.

Interleaving the source data prior to transmission addresses this problem. Interleaving reorganizes the source data, so that consecutive bits in the channel are not from the same code word. With interleaving, bits corrupted by an interference pulse are distributed across multiple code words. Figure 7.5-28 is for the same example as in Figure 7.5-27, but with interleaving.

The interleaving process is illustrated in Figure 7.5-28(a). In Figure 7.5-28(b), the interference pulse is shown corrupting two bits, as before. When the data is demodulated and de-interleaved in the receiver, however, the corrupted bits are seen to reside in two different code words. This is shown in Figure 7.5-28(c). The effect is the same as splitting the interference pulse into two shorter – and therefore less harmful – pulses.

In this example, the interleaving process is applied to a group of four code words. The process would be repeated for every group of four code words for the duration of the transmission. By increasing the number of code words in the interleave group (referred to as the interleaver depth L), the protection is extended to longer pulses. When the data is interleaved with depth L , an interference pulse will overload the decoder only if $T_i > LtT_b$.

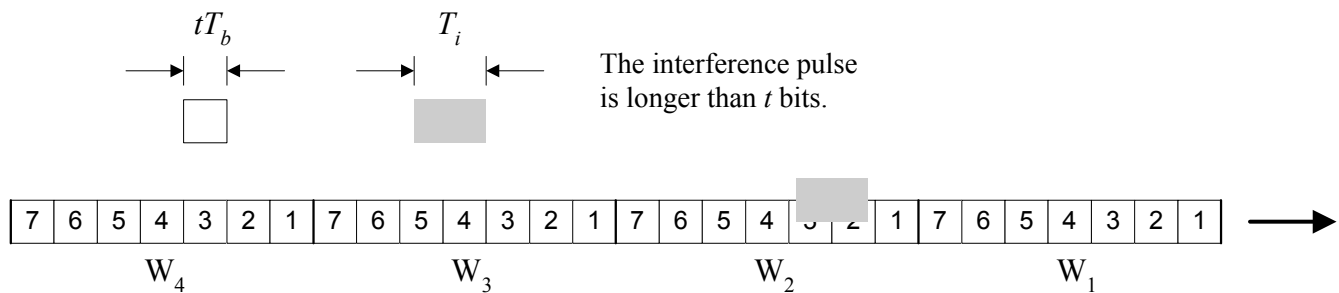

Figure 7.5-27. Pulsed Interference Without Interleaving

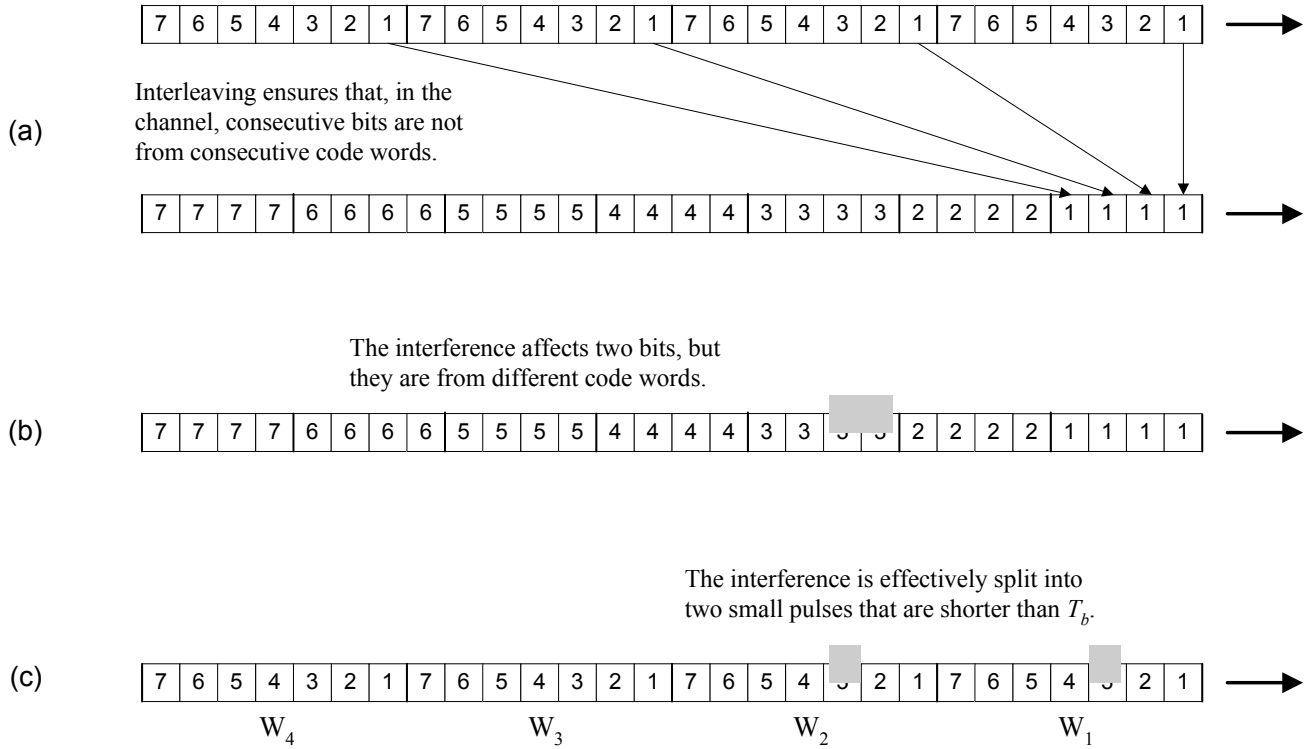

Figure 7.5-28. Pulsed Interference With Interleaving

7.6 CONVOLUTIONAL CODES

7.6.1 Description

Convolutional coding is the other major approach to FEC coding. Convolutional coding and decoding techniques are very briefly described here. A more detailed discussion of convolutional codes can be found in the literature including the Proakis textbook.

In contrast to block coding, which transforms k -bit messages into n -bit code words, convolutional coding is applied to a continuous stream of data to produce another continuous stream of data. Redundancy is added in the process, so the encoder output data rate is higher than the encoder input (information) data rate. The ratio of input to output data rates is called the rate of the code, denoted R .

Convolutional encoding is implemented with a shift register of several stages, and two or more modulo-2 adders. The number of stages is called the constraint length of the code, denoted k . Certain stages are connected to the adders, so that at any given time the output of each adder is the modulo-2 sum of the shift register stages to which it is connected. The input to the shift register is the sequence of information bits, so the clock rate of the shift register is the data rate of the information sequence. The output is taken from the adders. Each adder is sampled in turn, such that all of the adders are sampled once per clock cycle.

Convolutional codes are given the designation (R, k) , in recognition of the dependence on the rate and constraint length. In addition to these parameters, a particular convolutional code is characterized by the specific connections between shift register stages and adders. These connections may be designated graphically, using a diagram of the sequential logic circuit. Alternatively, the connections may be specified in terms of code tap connections. A code tap connection is represented by a k -bit symbol $G = (g_{k-1}, \dots, g_1, g_0)$ that designates the connections of a particular adder. If the i^{th} stage is connected to the adder, then $g_i = 1$, otherwise $g_i = 0$. There will be one code tap connection symbol for each adder in the encoder circuit. A $(1/2, 3)$ convolutional encoder is illustrated in Figure 7.6-1.

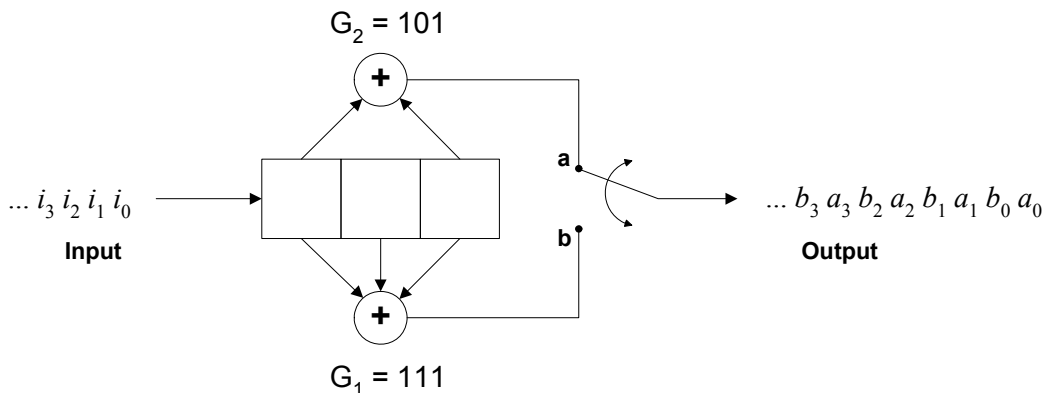

Figure 7.6-1. A $(1/2, 3)$ Convolutional Encoder

Several convolutional codes are listed in Table 7.6-1. These are all rate-1/2 codes, so there are two code tap connections for each code.

Table 7.6-1. Rate $R = 1/2$ Convolutional Codes

Constraint Length k	Code Tap Connections G_1, G_2
3	111, 101
4	1111, 1101
5	11101, 10011
6	111101, 101011
7	1111001, 1011011
8	11111001, 10100111

7.6.2 Decoding Convolutional-Coded Data

The convolutional decoder examines an incoming sequence of data to determine the likelihood that such a sequence could have actually been transmitted. If the decoder decides that the sequence contains errors, it makes the necessary adjustments to the data. Unlike the block decoder, the convolutional decoder is not limited to a particular sequence length. Typically, convolutional decoders examine sequences that are several times longer than the constraint length. This process is called finite-memory decoding.

The decoding process is based on the state-transition properties of the encoder, which ensures that only certain coded sequences are possible. A convolutional code can be represented by a code tree, which is a diagram that indicates the transitions – and therefore the sequences – that are possible. One of the most important and universal convolutional decoders is called the Viterbi algorithm. This algorithm is typically applied to convolutional codes with rates of $1/2$ to $3/4$, constraint lengths of 3 to 8, and memories of 3 or 4 times the constraint length. Viterbi decoders generally employ soft-decision decoding.

7.6.3 BER Calculation for Convolutional Coding

There is an analytical approach for estimating the output BER for a convolutional decoder. An explanation of the technique and of the parameters involved is beyond the scope of this Handbook. The objective is to simply show how the BER can be calculated.

The technique involves two parameters D and N and three functions $T(D)$, $T(D,N)$, and $P(D)$. The *transfer function* $T(D)$ of the convolutional code is derived from the state-transition representation of the code. It is a polynomial:

$$T(D) = \sum_{j=d}^{\infty} a_j D^j \quad (7-7)$$

where

- d = minimum free distance of the code
- a_j = polynomial coefficient for the code

The transfer function is extended to form $T(D,N)$ by adding a parameter N , which is also based on the state-transition representation. Then that function is differentiated with respect to N , and evaluated at $N = 1$. The new polynomial function $P(D)$ may be called the derivative polynomial:

$$P(D) = \left. \frac{d}{dN} T(D, N) \right|_{N=1} = \sum_{j=d}^{\infty} c_j D^j \tag{7-8}$$

where

c_j = derivative polynomial coefficient for the code

Lists of the functions $T(D)$ and $P(D)$ for various codes are published in the literature, and are often provided with system descriptions. A few examples are given in Tables 7.6-2 and 7.6-3.

Table 7.6-2. Transfer Functions for $R = 1/2$ Convolutional Codes

k	T(D)
3	$D^5 + 2D^6 + 4D^7 + 8D^8 + 16D^9 \dots$
4	$D^6 + 3D^7 + 5D^8 + 11D^9 + 25D^{10} \dots$
5	$2D^7 + 3D^8 + 4D^9 + 16D^{10} + 37D^{11} \dots$
6	$D^8 + 8D^9 + 7D^{10} + 12D^{11} + 48D^{12} \dots$
7	$11D^{10} + 38D^{12} + 193D^{14} + 1331D^{16} + 7230D^{18} \dots$

Table 7.6-3. Derivative Polynomials for $R = 1/2$ Convolutional Codes

k	P(D)
3	$D^5 + 4D^6 + 12D^7 + 32D^8 + 80D^9 \dots$
4	$2D^6 + 7D^7 + 18D^8 + 49D^9 + 130D^{10} \dots$
5	$4D^7 + 12D^8 + 20D^9 + 72D^{10} + 225D^{11} \dots$
6	$2D^8 + 36D^9 + 32D^{10} + 62D^{11} + 332D^{12} \dots$
7	$36D^{10} + 211D^{12} + 1404D^{14} + 11633D^{16} + 76628D^{18} \dots$

The first step is to identify the derivative polynomial $P(D)$ for the code. The lowest degree is d , the minimum free distance of the code. The next step is to identify the hard-decision demodulator transfer function. This equation expresses the BER at the demodulator output as a function of E_b/N_o :

$$BER_{\text{hard}} = F\left(\frac{E_b}{N_o}\right) \tag{7-9}$$

where

$$\begin{aligned} BER_{\text{hard}} &= \text{BER for a hard-decision demodulator} \\ F(x) &= \text{function for a given demodulator type} \end{aligned}$$

The BER at the decoder output is approximated by the following upper bound:

$$BER = \sum_{j=d}^{\infty} c_j F\left(jR \frac{E_b}{N_o}\right) \quad (7-10)$$

where R is code rate of the convolutional code.

As an example, consider a BPSK system with soft-decision $(1/2, 7)$ Viterbi decoding. The derivative polynomial $P(D)$ is the last one listed in Table 7.6-3. Equation 6-19 gives the BPSK function $F(x)$:

$$F(x) = \frac{1}{2} \operatorname{erfc}(\sqrt{x}) \quad (7-11)$$

Substituting that function into Equation 7-8 gives:

$$\begin{aligned} BER &= \sum_{j=d}^{\infty} c_j \frac{1}{2} \operatorname{erfc}\left(\sqrt{jR \frac{E_b}{N_o}}\right) \\ &= \frac{36}{2} \operatorname{erfc}\left(\sqrt{\frac{10}{2} \frac{E_b}{N_o}}\right) + \frac{211}{2} \operatorname{erfc}\left(\sqrt{\frac{12}{2} \frac{E_b}{N_o}}\right) + \frac{1404}{2} \operatorname{erfc}\left(\sqrt{\frac{14}{2} \frac{E_b}{N_o}}\right) + \dots \end{aligned} \quad (7-12)$$

Of the five $P(D)$ terms shown in Table 7.6-3, only three are explicitly shown in Equation 7-12. More terms can be included for greater accuracy.

These equations apply to soft-decision decoding. If hard-decision convolutional decoding is encountered (which is unlikely), its performance will be roughly 2 dB worse.

7.6.4 BER Curves

Figure 7.6-2 shows the BER vs. E_b/N_o curves for a soft-decision $(1/2, 7)$ Viterbi decoder and for various demodulator types. For these curves, the demodulator and FEC decoder are treated as one combined module.

Figure 7.6-3 shows BER curves for a rate $1/2$ convolutional coded PSK receiver ($M = 4$) with on-tune broadband AWGN interference.

Figure 7.6-4 shows BER curves for a rate $1/2$ convolutional coded PSK receiver ($M = 4$) with on-tune CW interference.

Figures 7.6-5, 7.6-6, 7.6-7, and 7.6-8 show BER curves for a rate $1/2$ convolutional coded PSK receiver ($M = 4$) with various on-tune pulsed interference scenarios (as annotated on the plots).

Figures 7.6-9 and 7.6-10 show BER curves for a rate $1/2$ convolutional coded PSK receiver ($M = 4$) with various off-tune pulsed interference scenarios (as annotated on the plots).

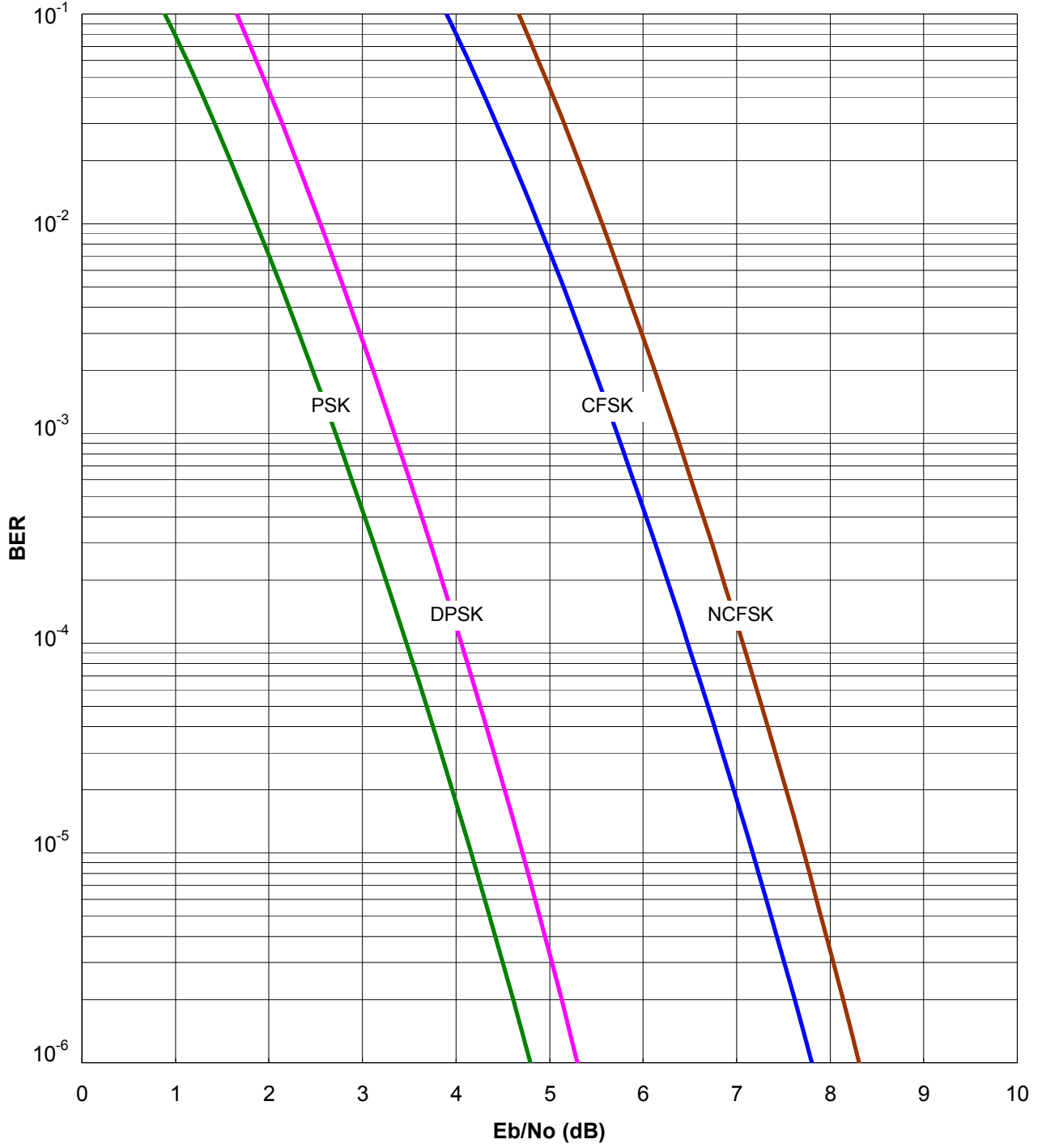

Figure 7.6-2. BER vs. E_b/N_0 Curves for Soft-decision (1/2, 7) Viterbi Decoder

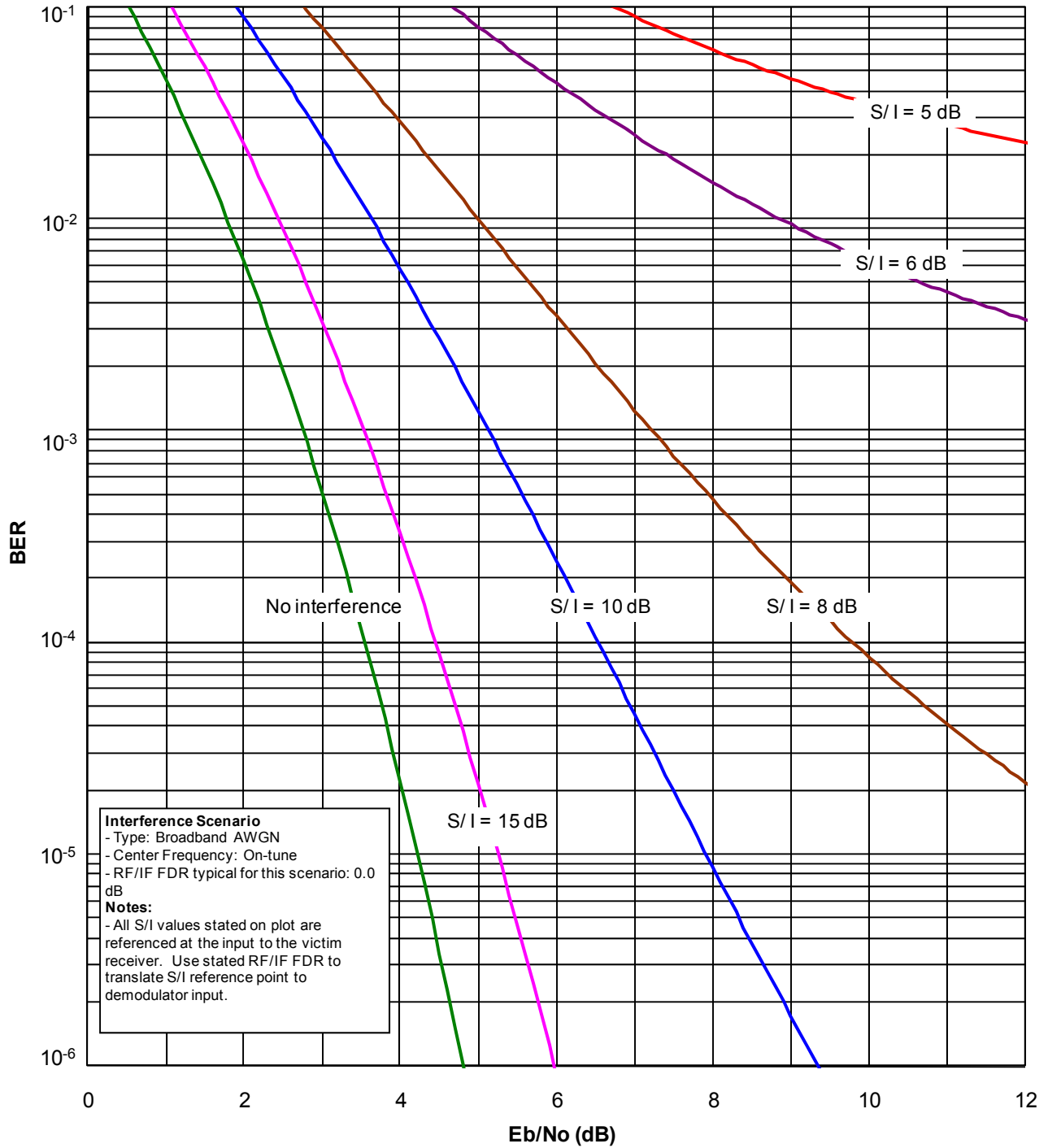

Figure 7.6-3. BER vs. E_b/N_0 Curves for Rate $\frac{1}{2}$ Convolutional Coded QPSK Receiver with On-Tune Broadband AWGN Interference

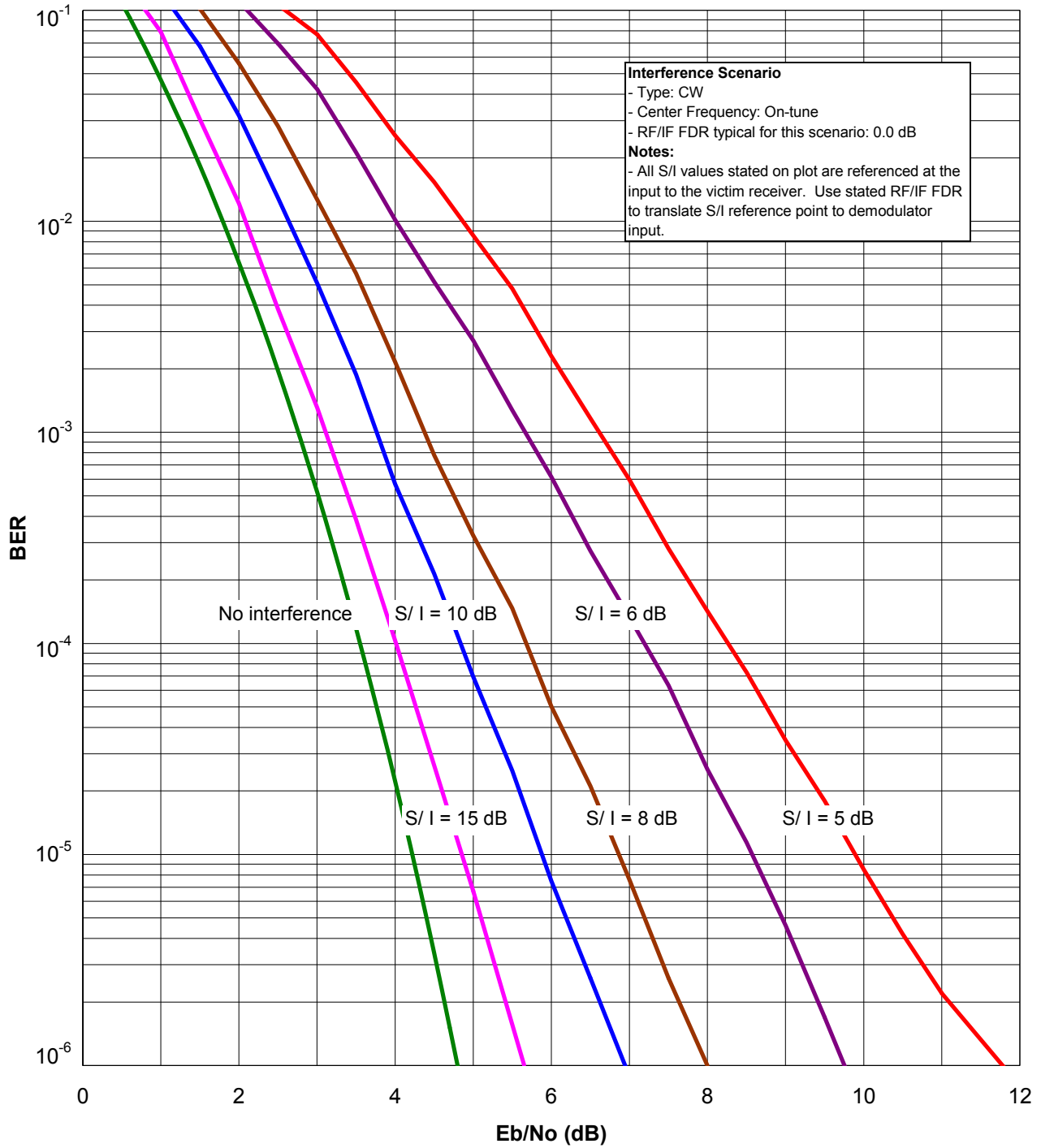

Figure 7.6-4. BER vs. E_b/N_0 Curves for Rate $\frac{1}{2}$ Convolutional Coded QPSK Receiver with On-Tune CW Interference

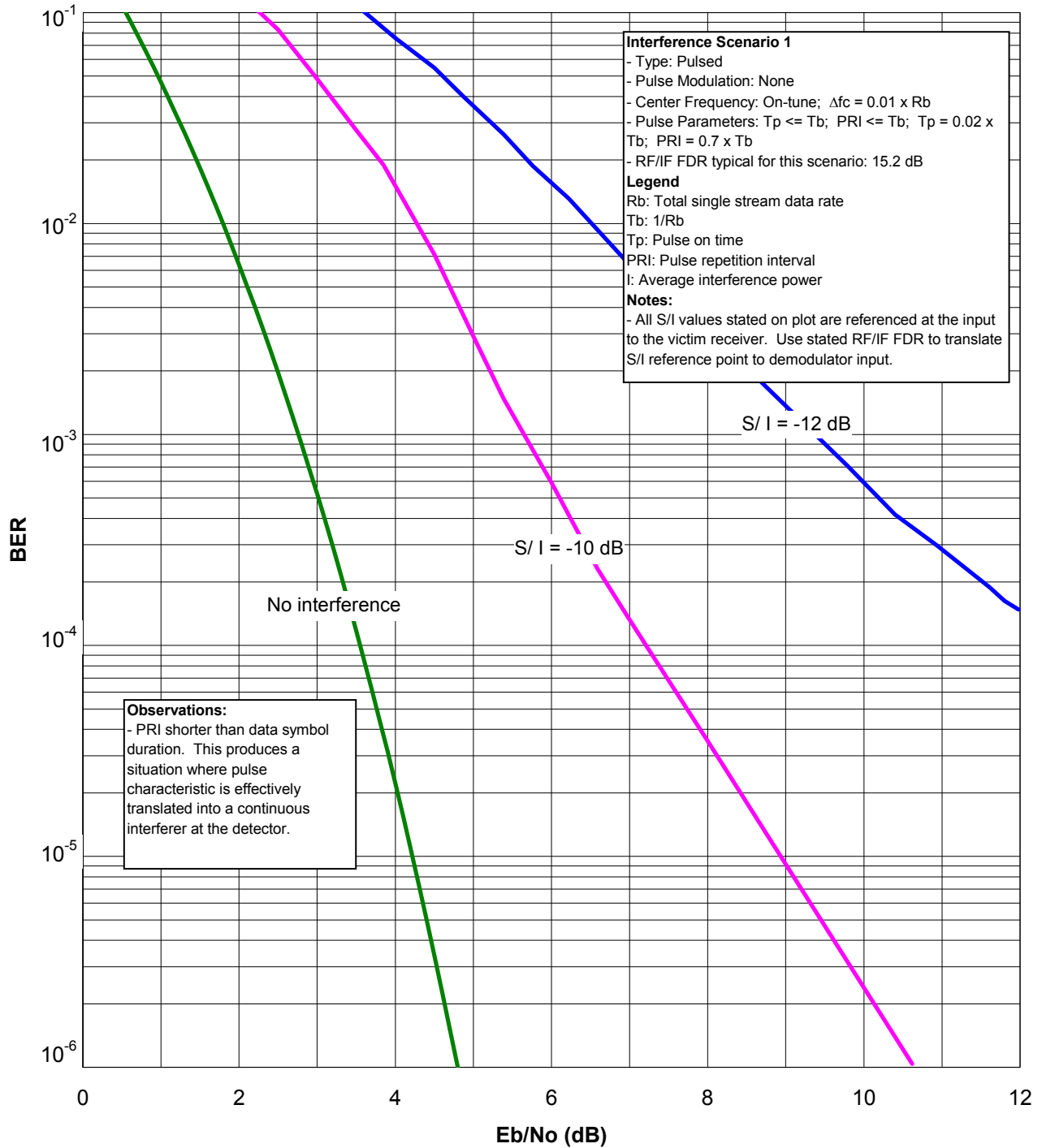

Figure 7.6-5. BER vs. E_b/N_o Curves for Rate $\frac{1}{2}$ Convolutional Coded QPSK Receiver with On-Tune Pulsed Interference Scenario 1

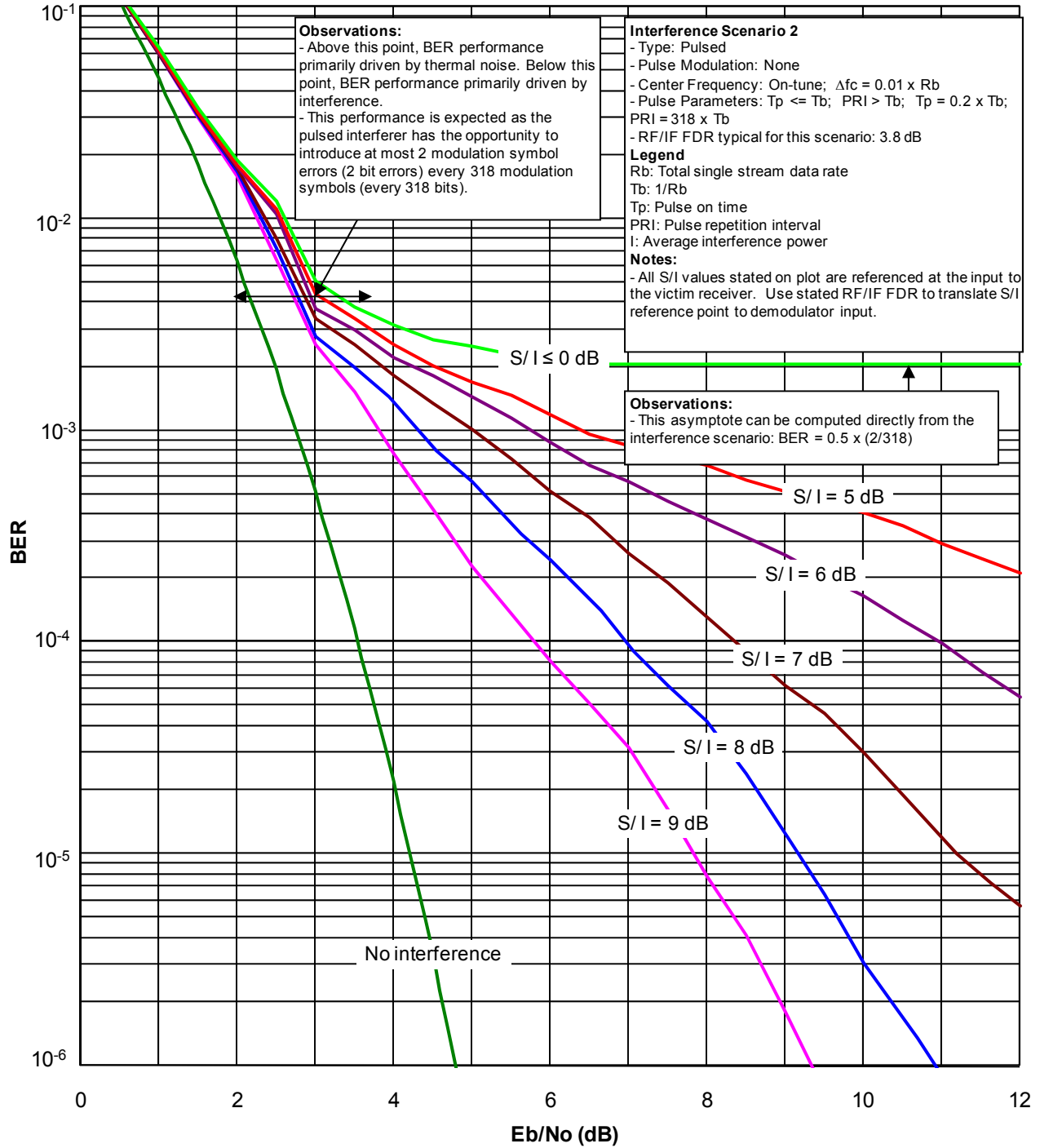

Figure 7.6-6. BER vs. E_b/N_o Curves for Rate 1/2 Convolutional Coded QPSK Receiver with On-Tune Pulsed Interference Scenario 2

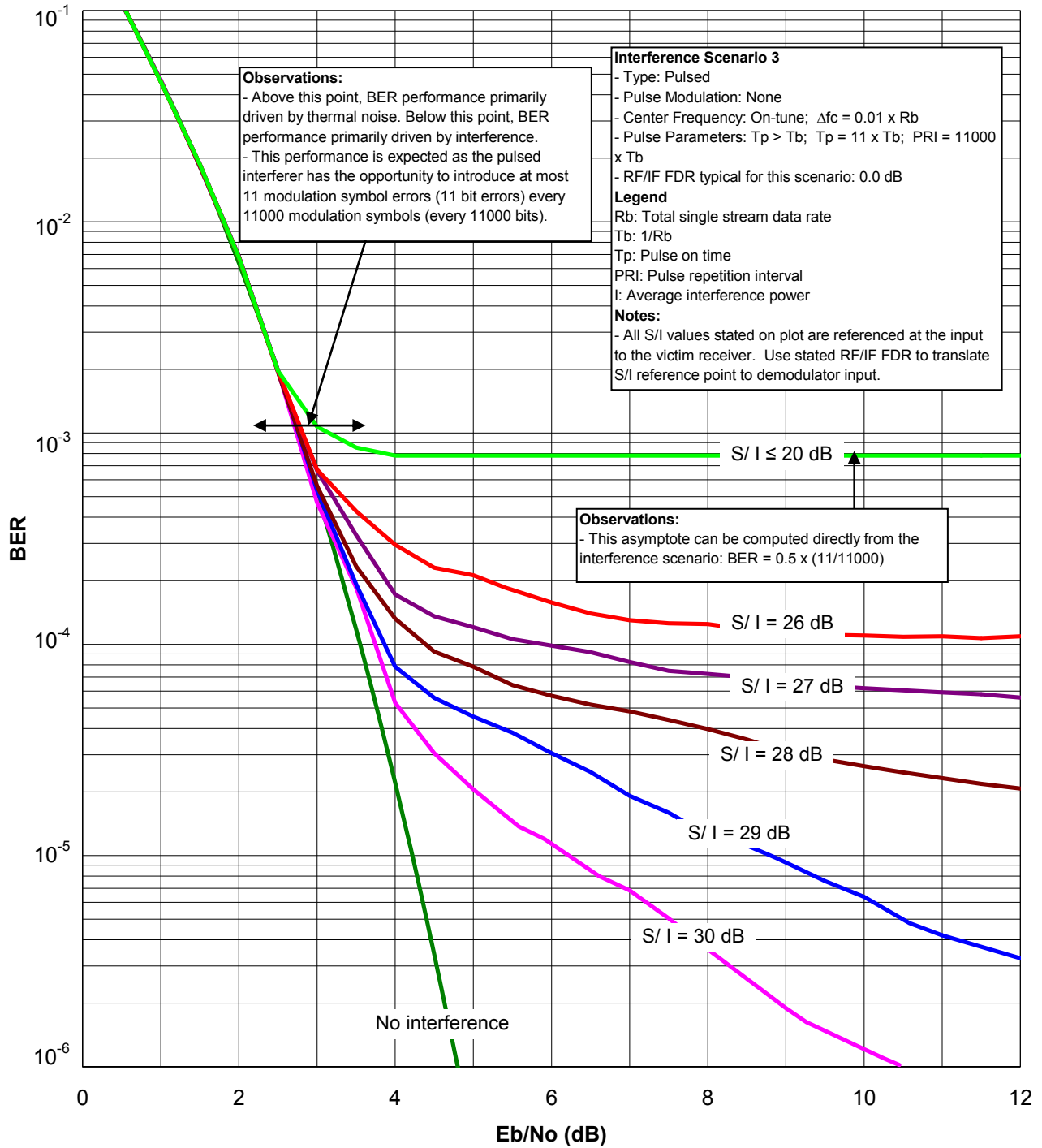

Figure 7.6-7. BER vs. E_b/N_0 Curves for Rate $1/2$ Convolutional Coded QPSK Receiver with On-Tune Pulsed Interference Scenario 3

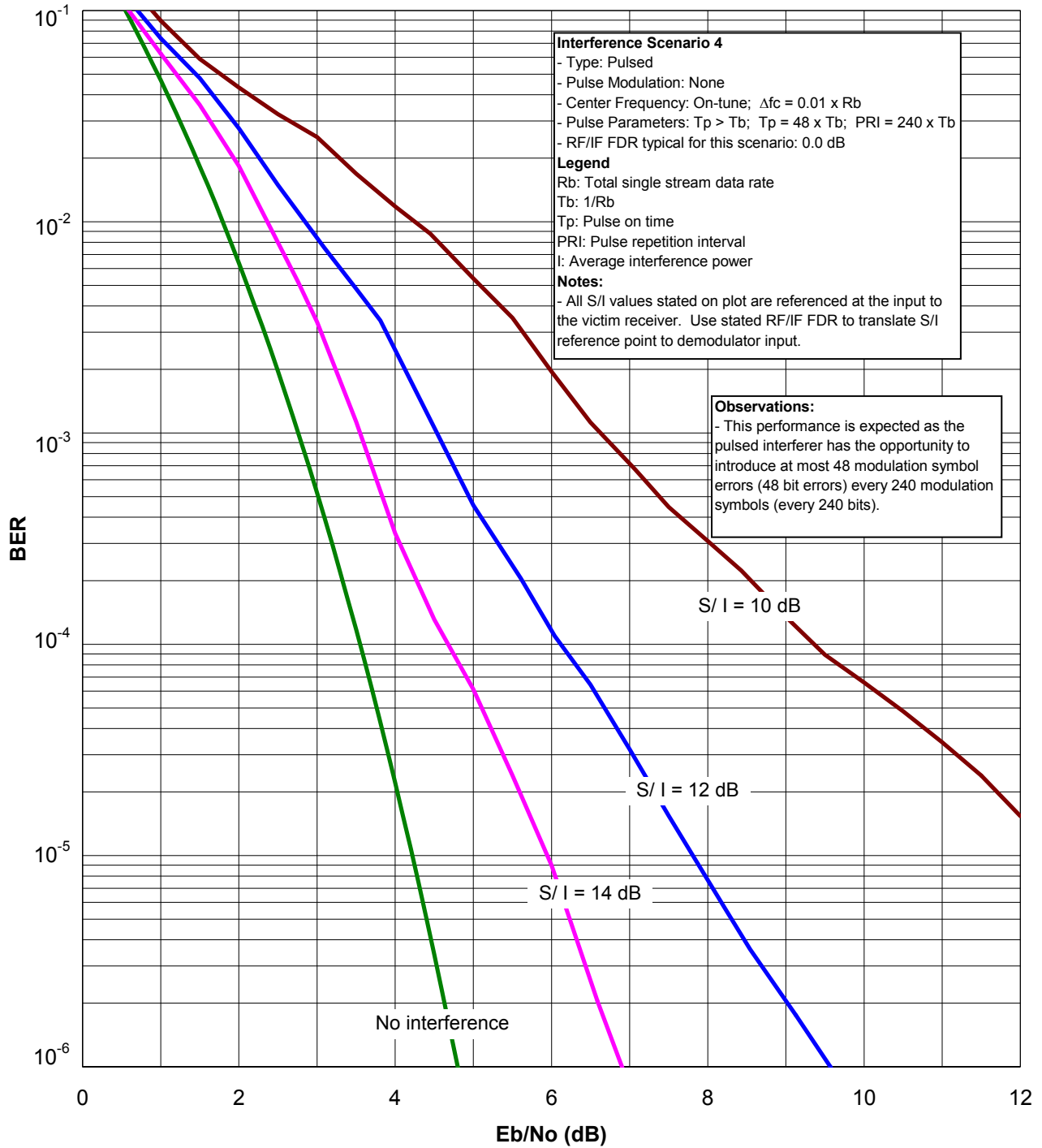

Figure 7.6-8. BER vs. E_b/N_o Curves for Rate $\frac{1}{2}$ Convolutional Coded QPSK Receiver with On-Tune Pulsed Interference Scenario 4

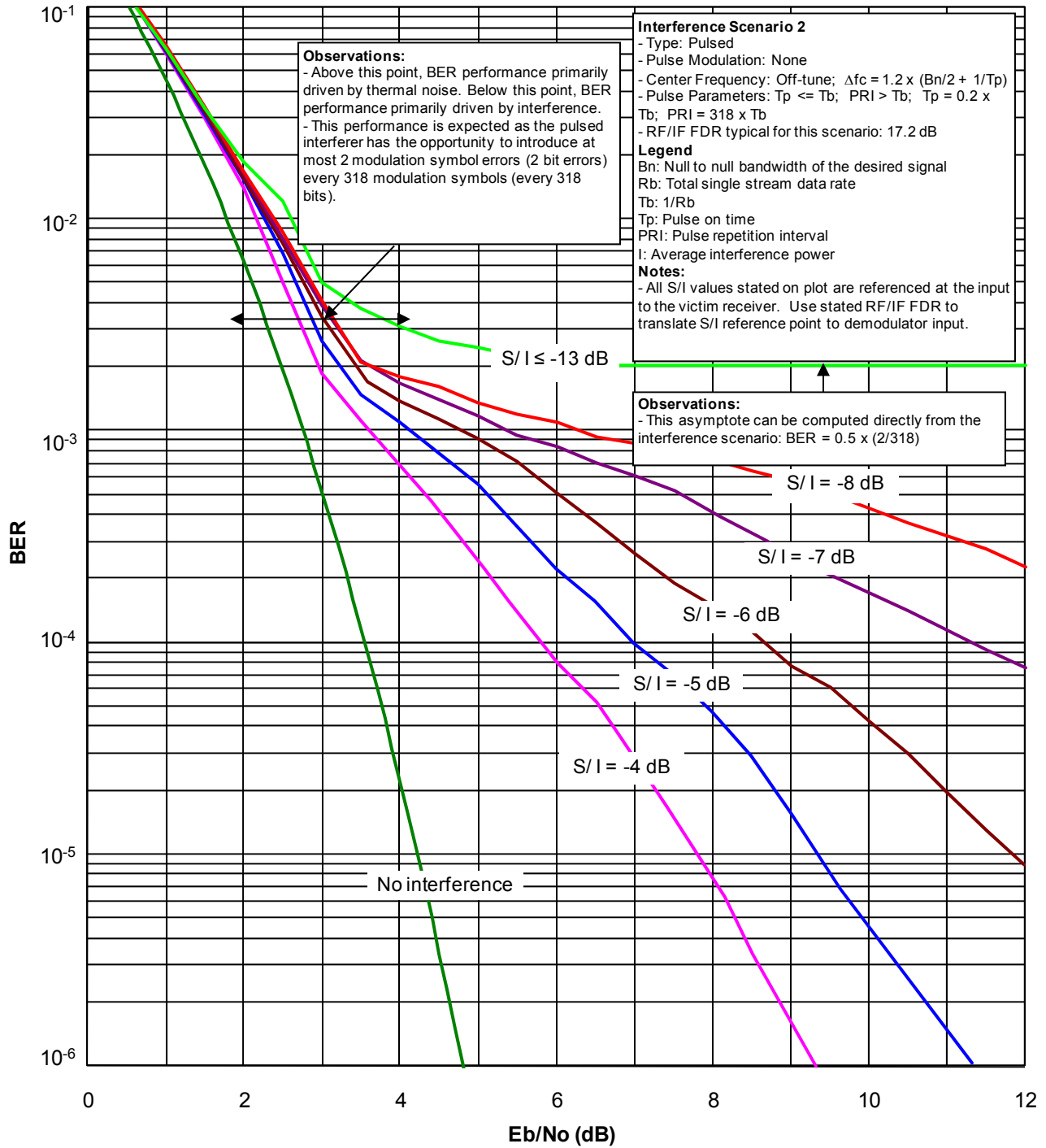

Figure 7.6-9. BER vs. E_b/N_o Curves for Rate 1/2 Convolutional Coded QPSK Receiver with Off-Tune Pulsed Interference Scenario 2

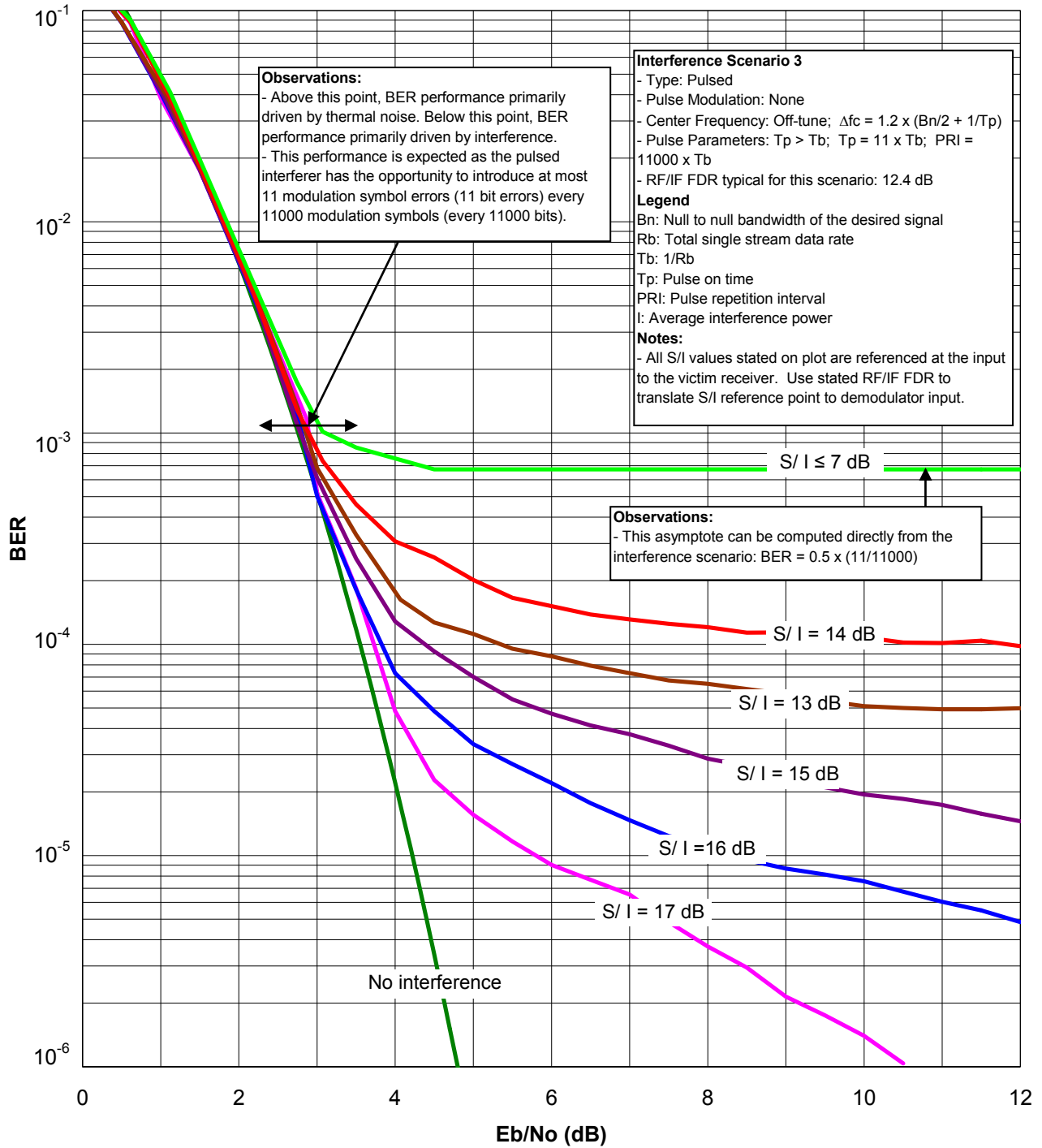

Figure 7.6-10. BER vs. E_b/N_o Curves for Rate $\frac{1}{2}$ Convolutional Coded QPSK Receiver with Off-Tune Pulsed Interference Scenario 3

7.7 8-ARY PHASE SHIFT KEYING/TRELLIS CODED MODULATION

7.7.1 Description

Trellis Coded Modulation (TCM) encoding and decoding techniques are very briefly described here. A more detailed discussion of TCM can be found in the literature including the Proakis textbook.

TCM was a method developed by Ungerboeck (1982) based on the principle of Mapping by Set Partitions. TCM combines the coding and modulation technique to achieve significant gain without bandwidth expansion.

This bandwidth-efficient signaling scheme is very relevant for communication systems for which a traditional approach of obtaining a coding gain through bandwidth expansion may not be an option.

As stated above, TCM combines the coding and modulation technique in such a way that the coding gain is achieved without increasing the required bandwidth, compared with uncoded modulation. It is termed trellis coded modulation because it simply combines convolutional codes with rate R and an

M -ary signal constellation is used for mapping.

TCM uses a signal set expansion rather than additional transmitted symbols to create redundancy typically introduced by coding. Hence, TCM system performance must be compared to uncoded systems that have the same spectral efficiency. In other words, the compared systems must have the same average energy per transmitted symbol. This requirement is enforced by reducing the amplitude of each signal point of the TCM scheme to that of an uncoded scheme.

Naturally, the reduced signal energy results in a reduced minimum distance between signal points that must be overcome by coding for TCM to achieve a positive coding gain compared with an uncoded system with the same average energy. The discussion above implies that, in practice, TCM use high-rate convolutional code (typically $R = k / (k + 1)$) to minimize the reduction in signal energy of coded systems.

The combination of trellis coded scheme and a constellation mapper in TCM is illustrated in Figure 7.7-1 below.

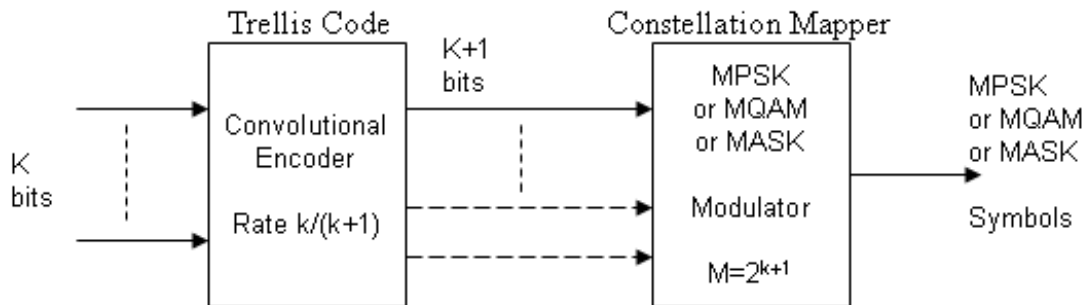

Figure 7.7-1. Trellis Coded Modulation

The M -ary signal mapper maps $M = 2^k$ input points into a larger constellation of $M = 2^{k+1}$ constellation points. By using a rate $R = k/(k+1)$, one extra bit is added to the symbol bit size, the constellation size is doubled to accommodate this bit. For instance, if the original signal is QPSK, the TCM encoder will put out 8-ary Phase Shift Keying (8PSK), 8PSK will become 16-QAM, and so on.

The constellation mapping is key to the TCM scheme and it is used in a way to improve the minimum Euclidean distance in the trellis paths. Figure 7.7-2 illustrates the method of mapping by set partitions. The k information bits maps to 2^{k+1} constellation points such that the transitions in the trellis can only occur along the largest Euclidean distance. The signals gets further apart increasing the Euclidean distance between the signals as the signal constellation is partitioned into co-sets.

The convolutional encoder must also be carefully chosen and traditional polynomials that provide good performance may not be optimal for use in a TCM scheme. The encoder should be chosen such that all branches leaving or entering a particular trellis node should be labeled from the same subset, and all parallel branches must be labeled from the same subset. These rules were defined by Ungerboeck to ensure maximum Euclidean separation of paths.

Note that a 4-state convolutional encoder provides limited gain in a TCM scheme as parallel transitions with smaller maximum Euclidean distance are present. Using higher number of states allows the elimination of parallel transitions.

Due to the trellis-based nature of TCM, existing Viterbi algorithms may easily be adapted for its decoding. The decoder must take soft-information into account, i.e., it must perform decoding using Euclidean metrics, not Hamming metrics.

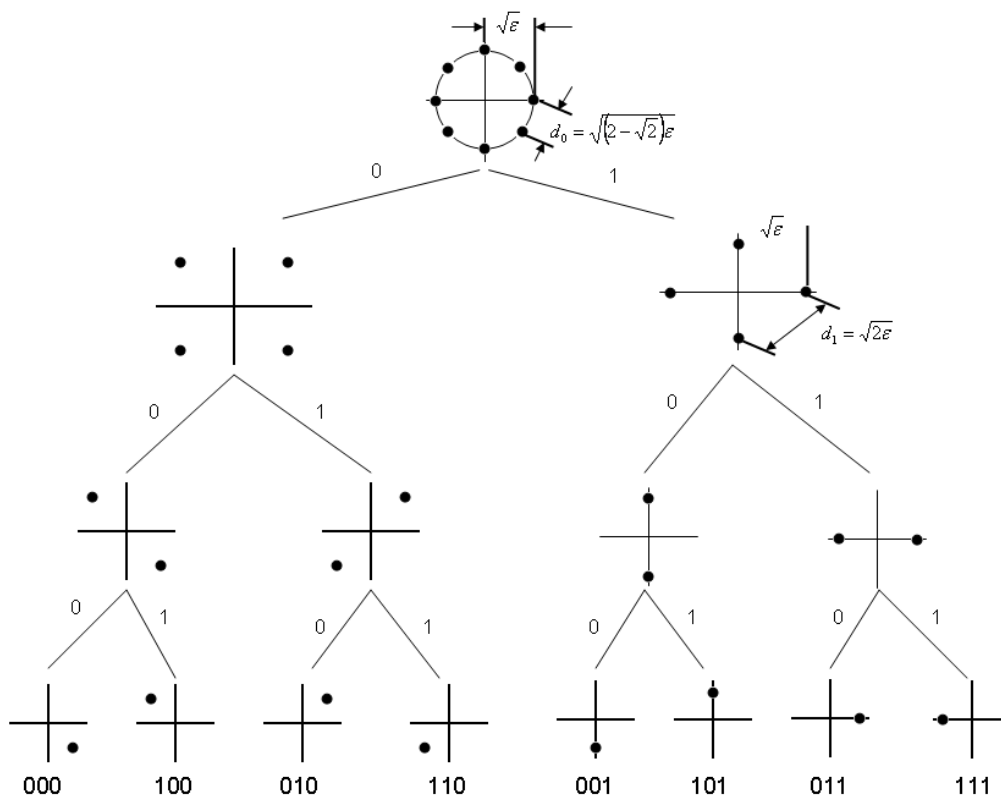

Figure 7.7-2. Constellation Mapping

7.7.2 BER Curves

Figure 7.7-3 shows BER curves for an 8PSK/TCM receiver with on-tune broadband AWGN interference.

Figure 7.7-4 shows BER curves for an 8PSK/TCM receiver with on-tune CW interference.

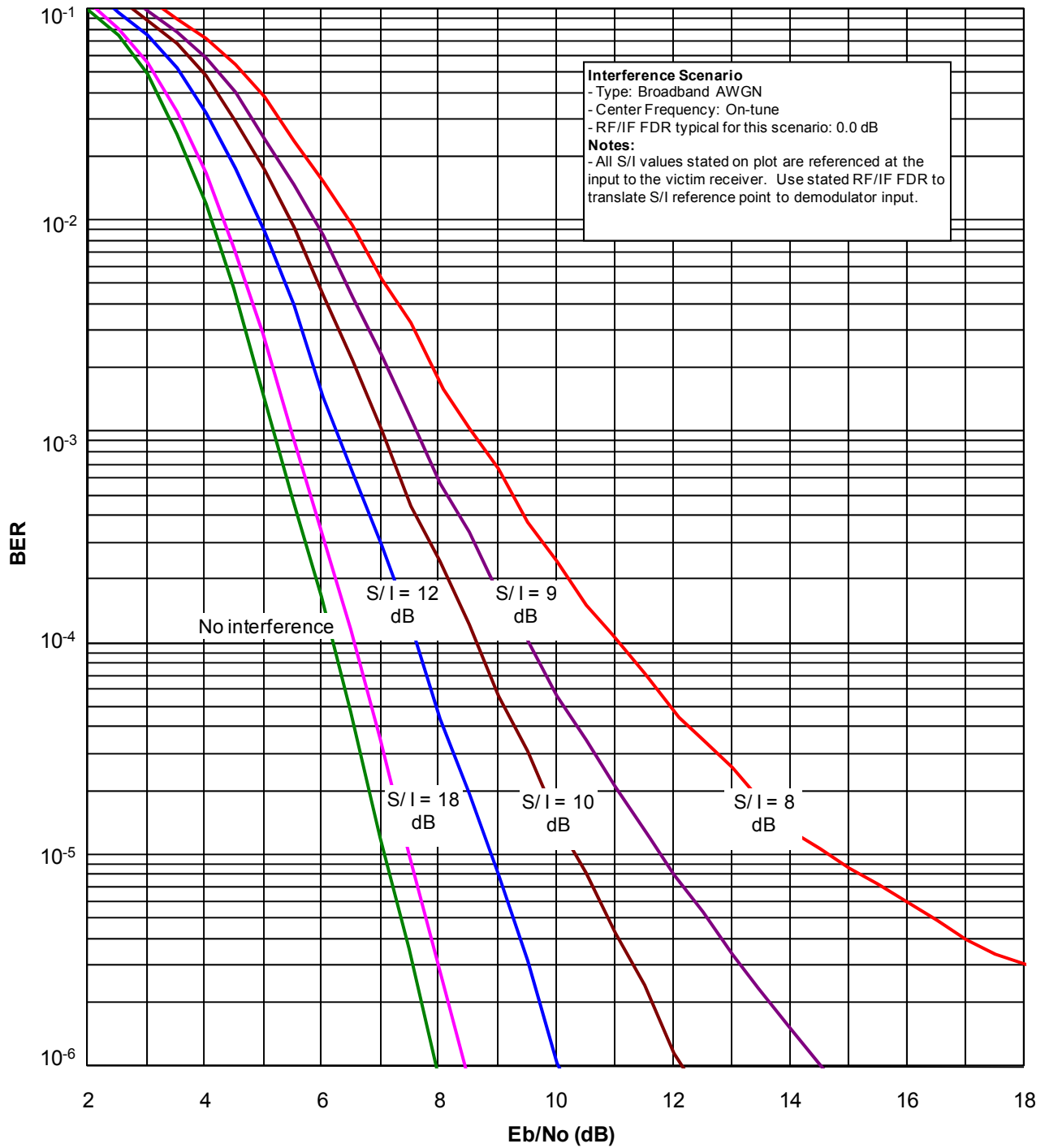

Figure 7.7-3. BER vs. E_b/N_o Curves for a 8PSK/TCM Receiver ($M = 8$) with On-Tune Broadband AWGN Interference

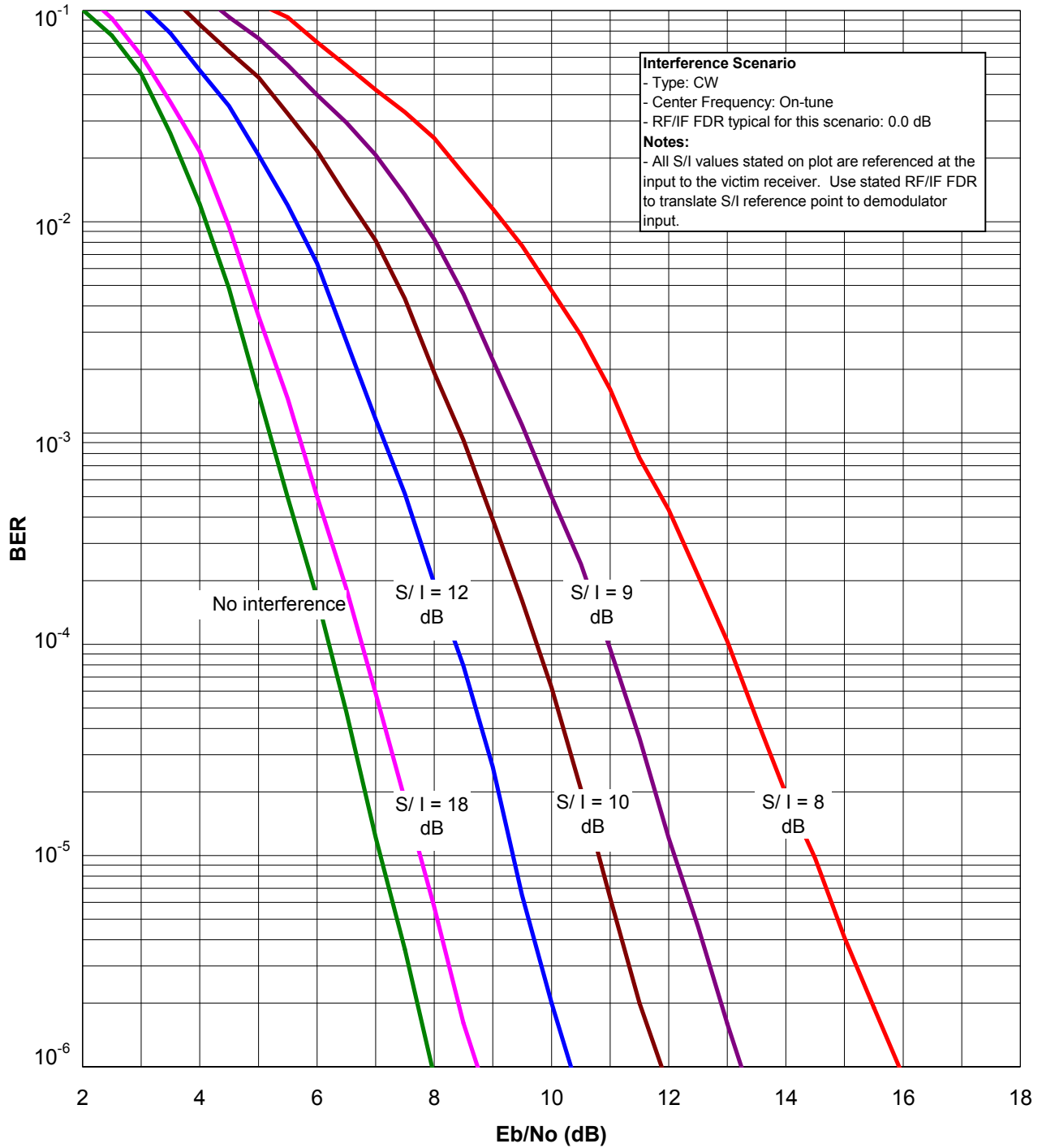

Figure 7.7-4. BER vs. E_b/N_o Curves for a 8PSK/TCM Receiver ($M = 8$) with On-Tune CW Interference

7.8 CONTINUOUS-PHASE MODULATION

7.8.1 Description

The term continuous-phase modulation (CPM) refers to signals that are designed to maintain continuity of phase for the duration of the transmission. This constraint results in a phase-modulated or frequency-modulated signal that has memory. This memory can be used to improve the BER of the demodulated signal, but at the cost of an increase in receiver complexity. The complexity is due to the fact that the receiver must perform recursive processing of the received signal to exploit the memory. One approach is to employ convolutional encoding and decoding in addition to the CPM. The receiver can incorporate the Viterbi decoding algorithm into the demodulation process. This algorithm is designed to consider signal history when determining the most probable value of the current demodulated symbol.

CPM generally encompasses a broad class of modulation types. The curves presented here are for continuous-phase FSK signals with Viterbi decoding. The modulation index is the ratio of the spacing of adjacent tones to the symbol rate

7.8.2 BER Curves

Figure 7.8-1 shows the BER vs. E_b/N_o curves for a soft-decision CPM receiver with $M = 2$ and a modulation index of $1/2$.

Figure 7.8-2 shows the BER vs. E_b/N_o curves for a soft-decision CPM receiver with $M = 4$ and a modulation index of $1/6$. For these curves, the demodulator and FEC (Viterbi) decoder are treated as one combined module.

In these graphs, the term “interference” and the variable I refer to CW interference. Any noise-like interference power is simply assumed to be added (in mW) to the noise power. For example, suppose there are two interfering signals: a CW signal and a noise-like signal. The S/I parameter is the ratio of the desired signal power to the CW interfering signal power, and the x-axis variable E_b/N_o is calculated with Equation 6-4, where N is the total noise-like power (including the receiver noise and the noise-like interfering signal).

The curves were generated by simulation. Each figure displays multiple curves. Each curve is a plot of BER vs. E_b/N_o . The curve labeled “No interference” applies to the case in which there is no CW interference. The other curves are for cases with CW interference. Each of those curves is labeled with the S/I for that curve. As expected, each curve shows that the BER decreases as the E_b/N_o increases. As also expected, for a given E_b/N_o the BER decreases as the S/I increases.

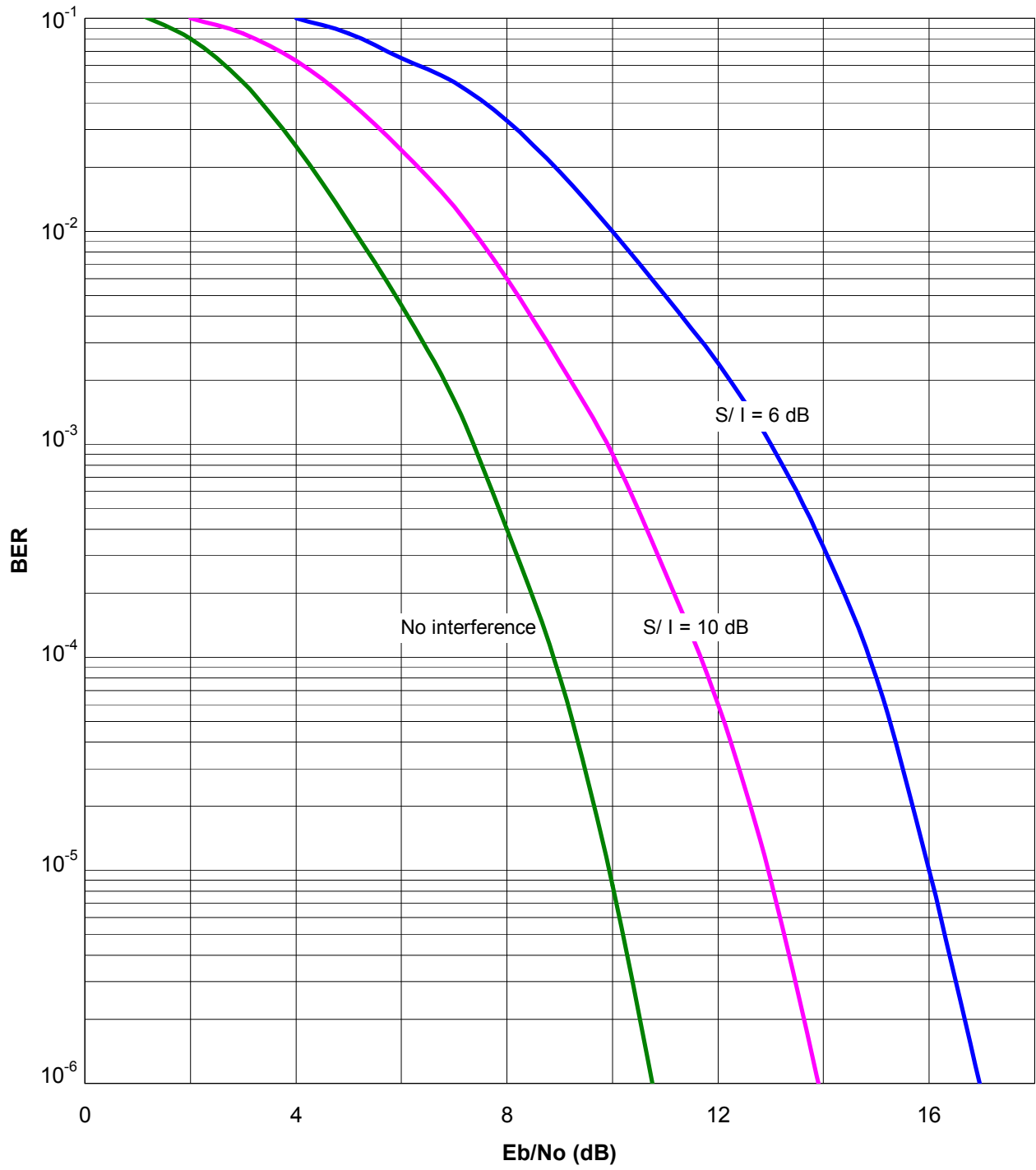

Figure 7.8-1. BER vs. E_b/N_o Curves for Binary CPM Decoder (Modulation Index 1/2)

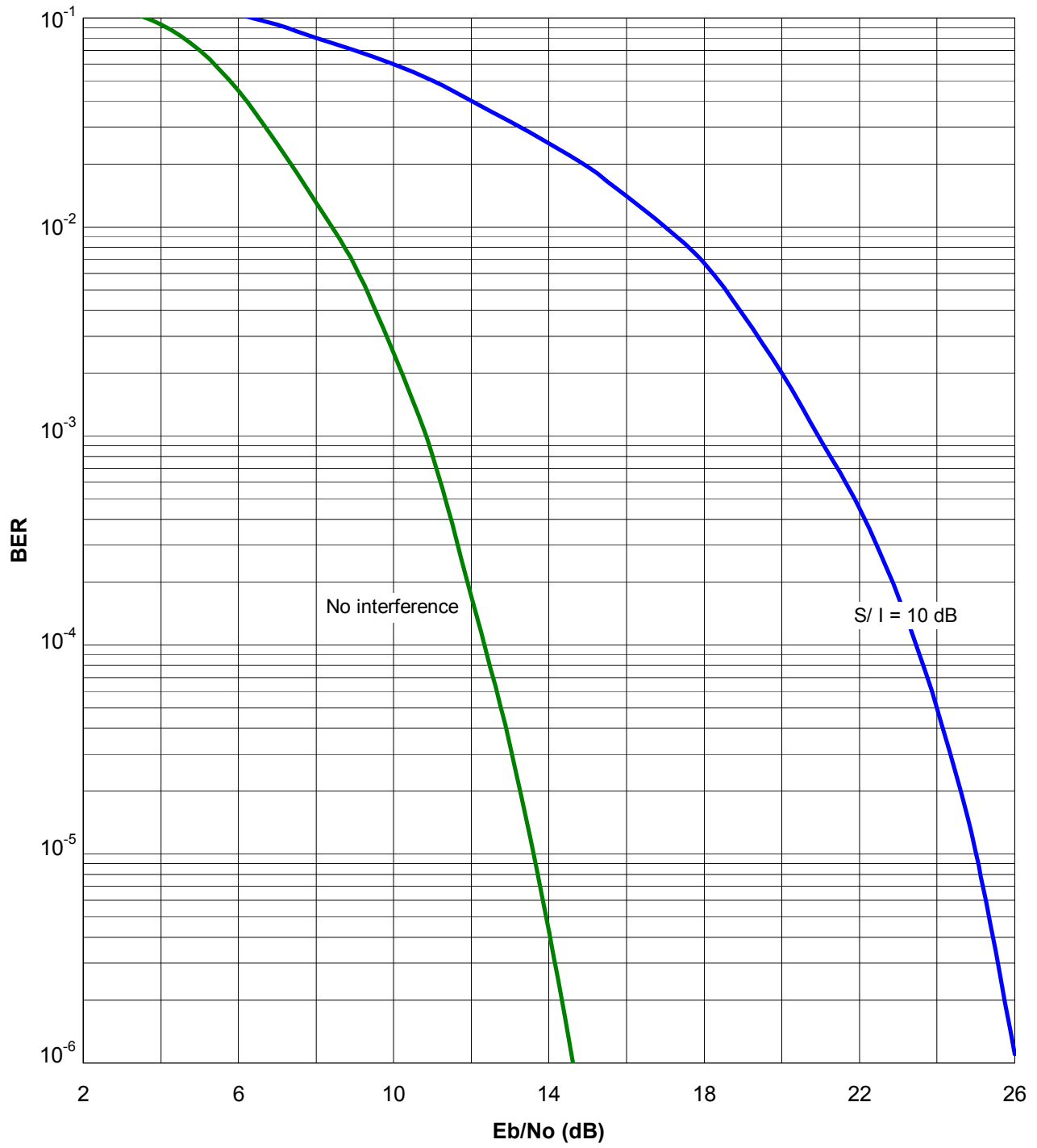

Figure 7.8-2. BER vs. E_b/N_0 Curves for 4-ary CPM Decoder (Modulation Index 1/6)

7.9 CONCATENATED CODES

7.9.1 Description

An RF communications system may employ two FEC coding systems to increase the protection against errors. The two codes are referred to as the inner code and the outer code, as shown in Figure 7.9-1. A typical application is a system that must guard against both random and burst errors. Suppose an (n, k) RS code capable of correcting two symbol errors per code word is specified as the outer code. If an interference burst can cause at most two symbol errors, the RS decoder can correct those errors. However, if in addition to those two errors there is another (random) error somewhere else in the code word, the decoder will be overloaded. The probability of random (non burst-related) errors occurring can be reduced by incorporating an inner code. This code would not be able to correct errors due to bursts, leaving that task to the outer code. The inner code would simply minimize the BER between bursts. A convolutional code is often used as the inner code in a concatenated coding system.

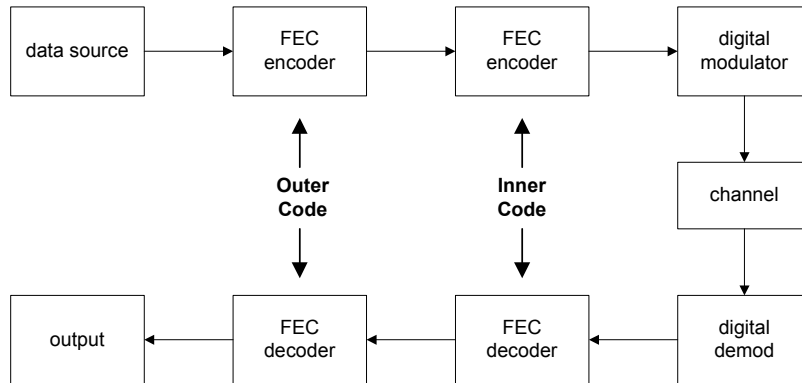

Figure 7.9-1. Concatenated Codes

The inner decoder may be either a soft-decision or hard-decision device, and the outer decoder is a hard-decision device. To analyze a concatenated coding scheme, the transfer functions for the individual decoders are computed and then combined. For example, if the inner decoder is a soft-decision decoder, then the demodulator and inner decoder are treated as one combined module. For a given E_b/N_0 and S/I, the output BER for that combined module is obtained from the appropriate curve. Then viewing that BER value as the input BER for the outer decoder, the output BER for the outer decoder is obtained from the curve for that device.

7.9.2 BER Curves

Figure 7.9-2 shows BER curves for a ((223,255) RS + rate $\frac{1}{2}$ convolution) coded PSK receiver ($M = 4$) with on-tune broadband AWGN interference.

Figure 7.9-3 shows BER curves for a ((223,255) RS + rate $\frac{1}{2}$ convolution) coded PSK receiver ($M = 4$) with on-tune CW interference.

Figures 7.9-4, 7.9-5, 7.9-6, and 7.9-7 show BER curves for a ((223,255) RS + rate $\frac{1}{2}$ convolution) coded PSK receiver ($M = 4$) with various on-tune pulsed interference scenarios (as annotated on the plots).

Figures 7.9-8 and 7.9-9 show BER curves for a ((223,255) RS + rate $\frac{1}{2}$ convolution) coded PSK receiver ($M = 4$) with various off-tune pulsed interference scenarios (as annotated on the plots).

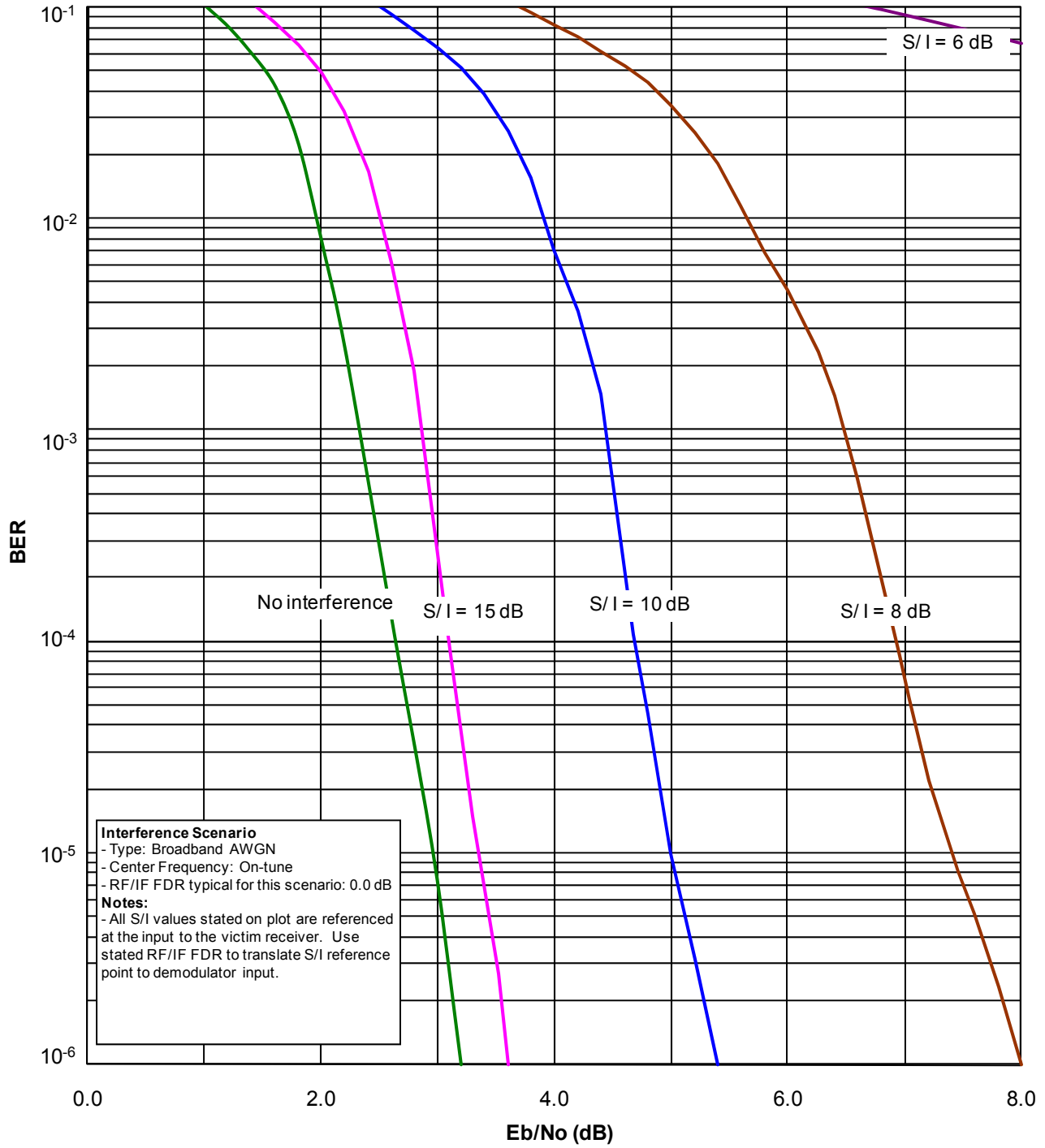

Figure 7.9-2. BER vs. E_b/N_o Curves for ((223,255) RS + rate 1/2 convolution) Coded PSK Receiver ($M = 4$) with On-Tune Broadband AWGN Interference

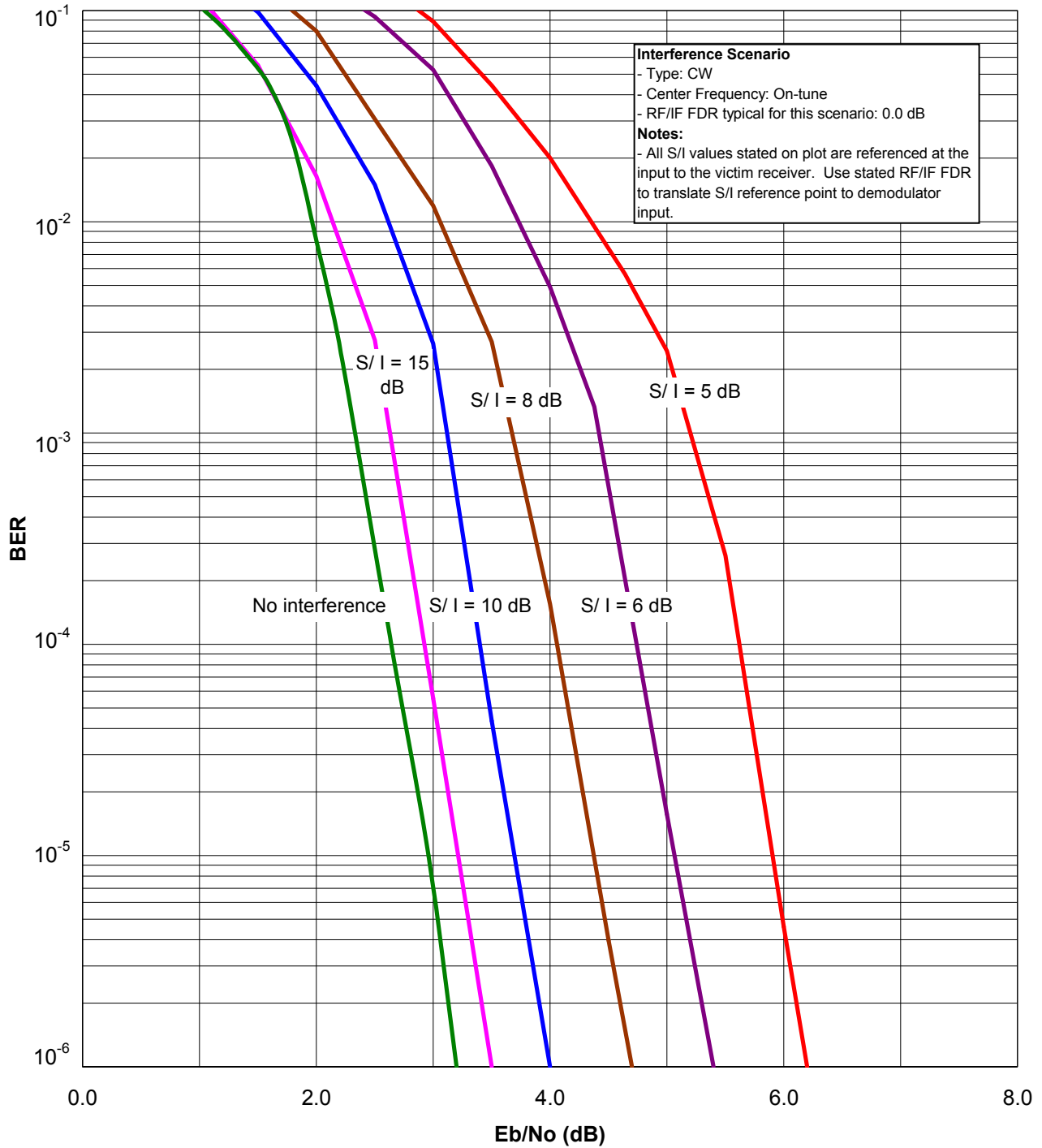

Figure 7.9-3. BER vs. E_b/N_o Curves for ((223,255) RS + rate 1/2 convolution) Coded PSK Receiver ($M = 4$) with On-Tune CW Interference

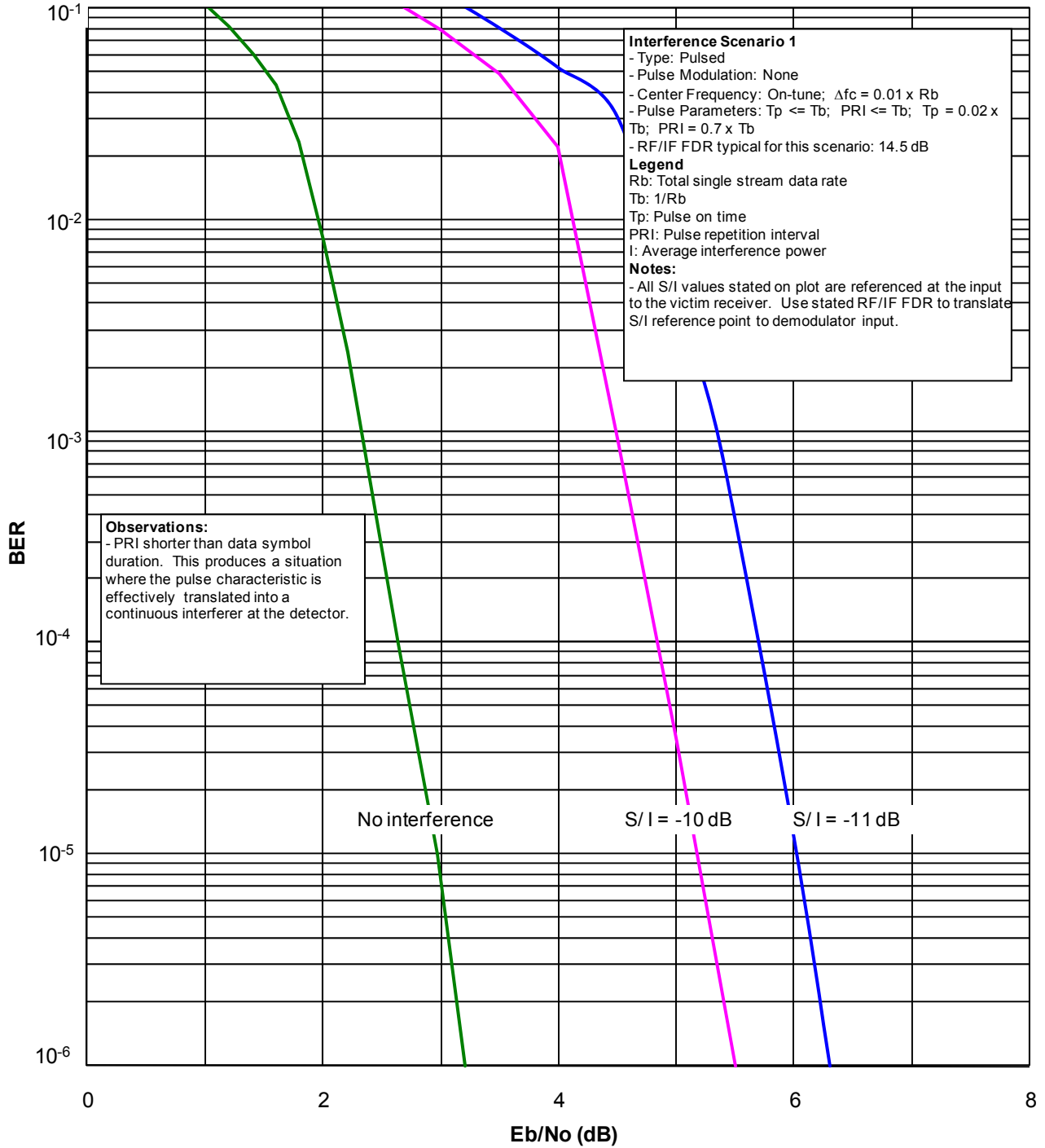

Figure 7.9-4. BER vs. E_b/N_o Curves for ((223,255) RS + rate 1/2 convolution) Coded PSK Receiver ($M = 4$) with On-Tune Pulsed Interference Scenario 1

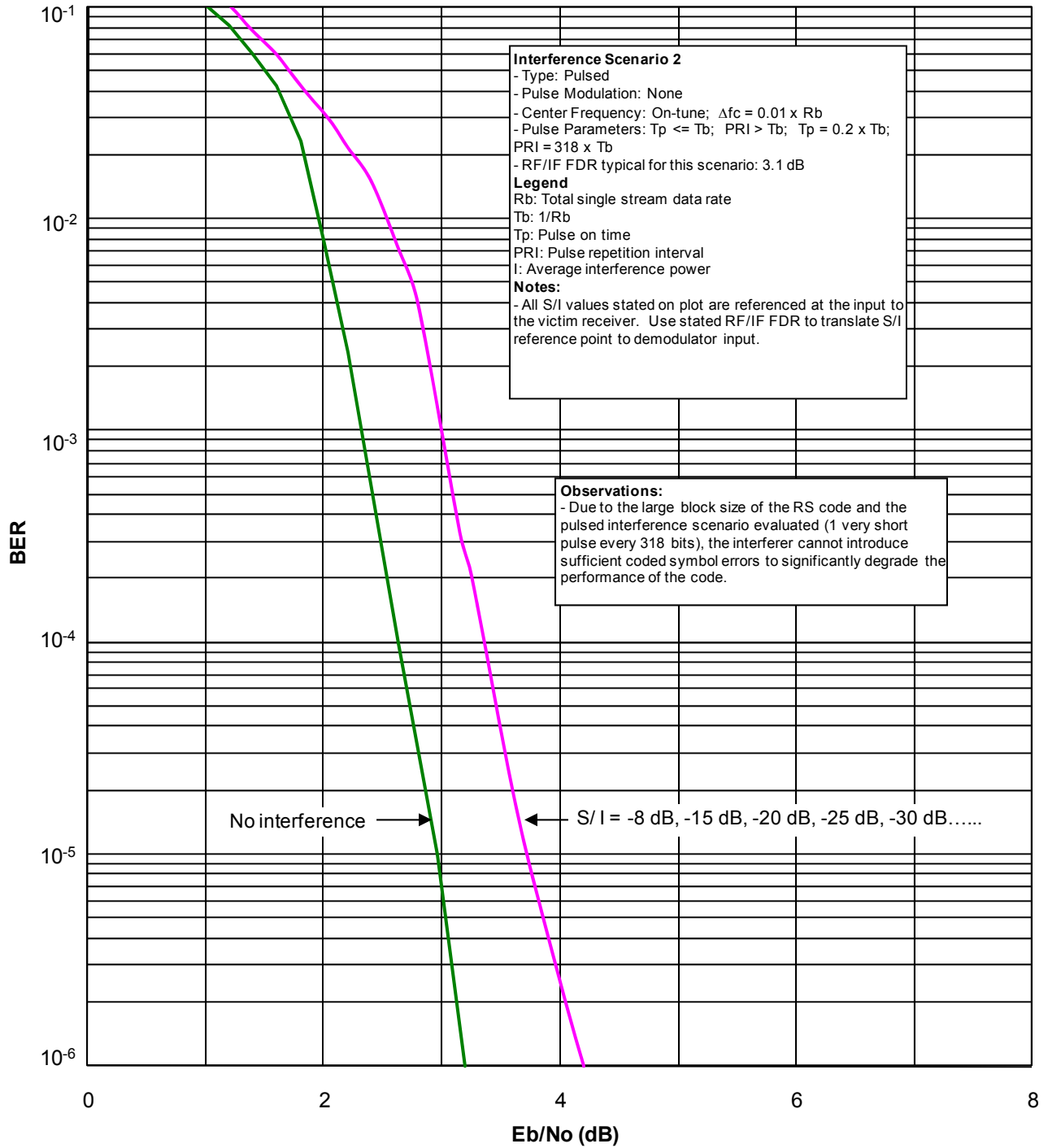

Figure 7.9-5. BER vs. E_b/N_o Curves for ((223,255) RS + rate 1/2 convolution) Coded PSK Receiver ($M = 4$) with On-Tune Pulsed Interference Scenario 2

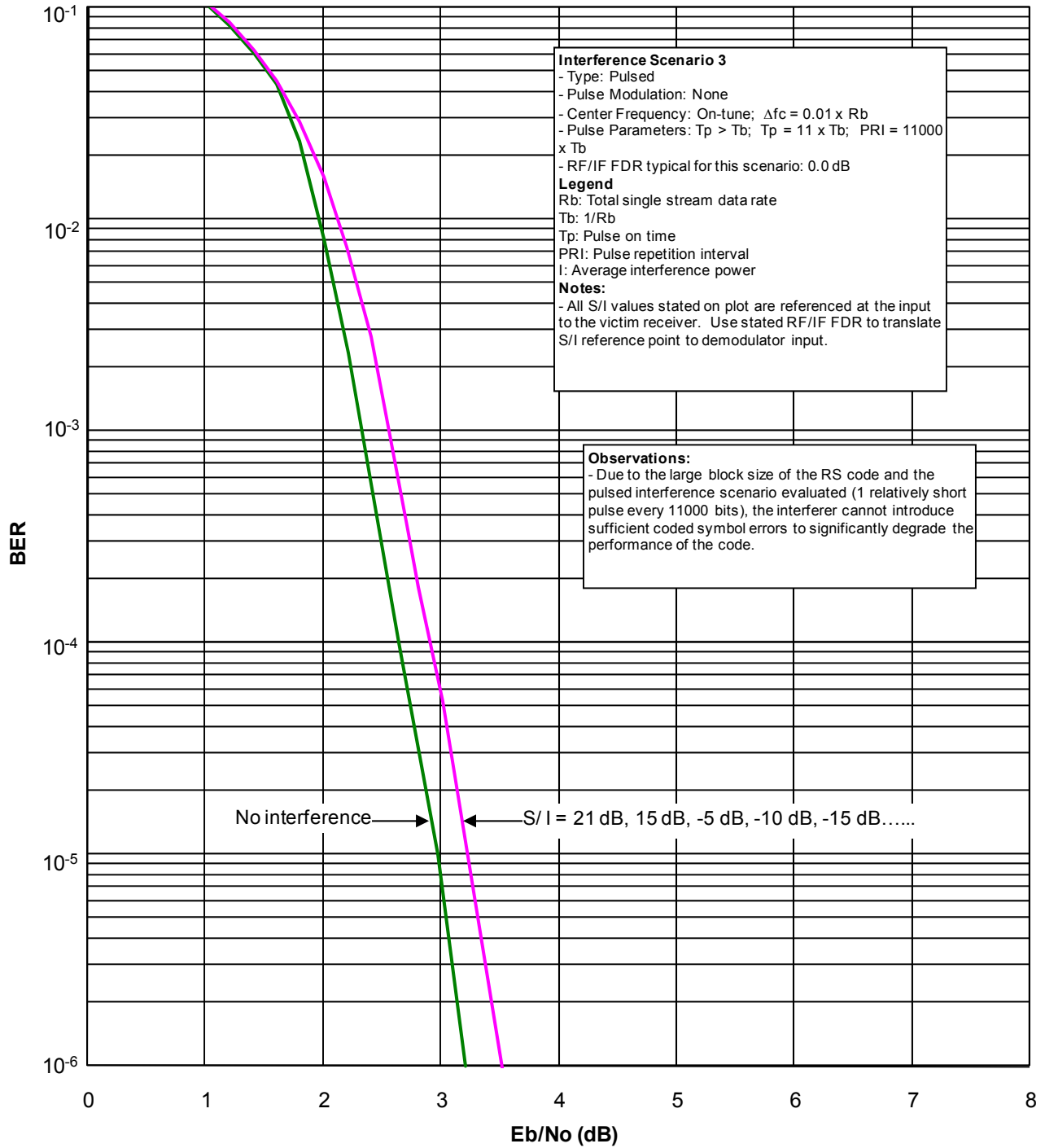

Figure 7.9-6. BER vs. E_b/N_o Curves for ((223,255) RS + rate 1/2 convolution) Coded PSK Receiver ($M = 4$) with On-Tune Pulsed Interference Scenario 3

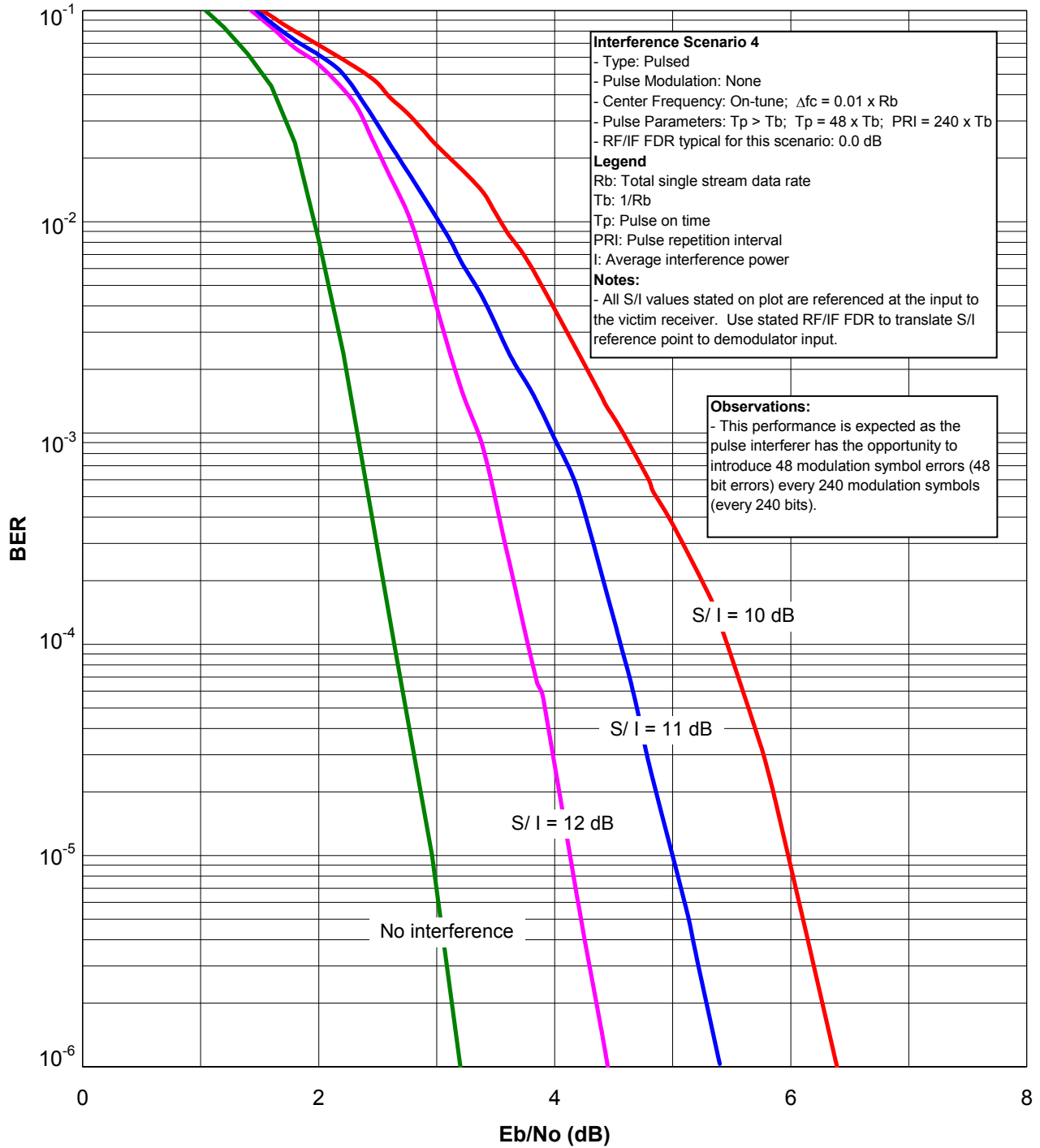

Figure 7.9-7. BER vs. E_b/N_0 Curves for ((223,255) RS + rate $\frac{1}{2}$ convolution) Coded PSK Receiver ($M = 4$) with On-Tune Pulsed Interference Scenario 4

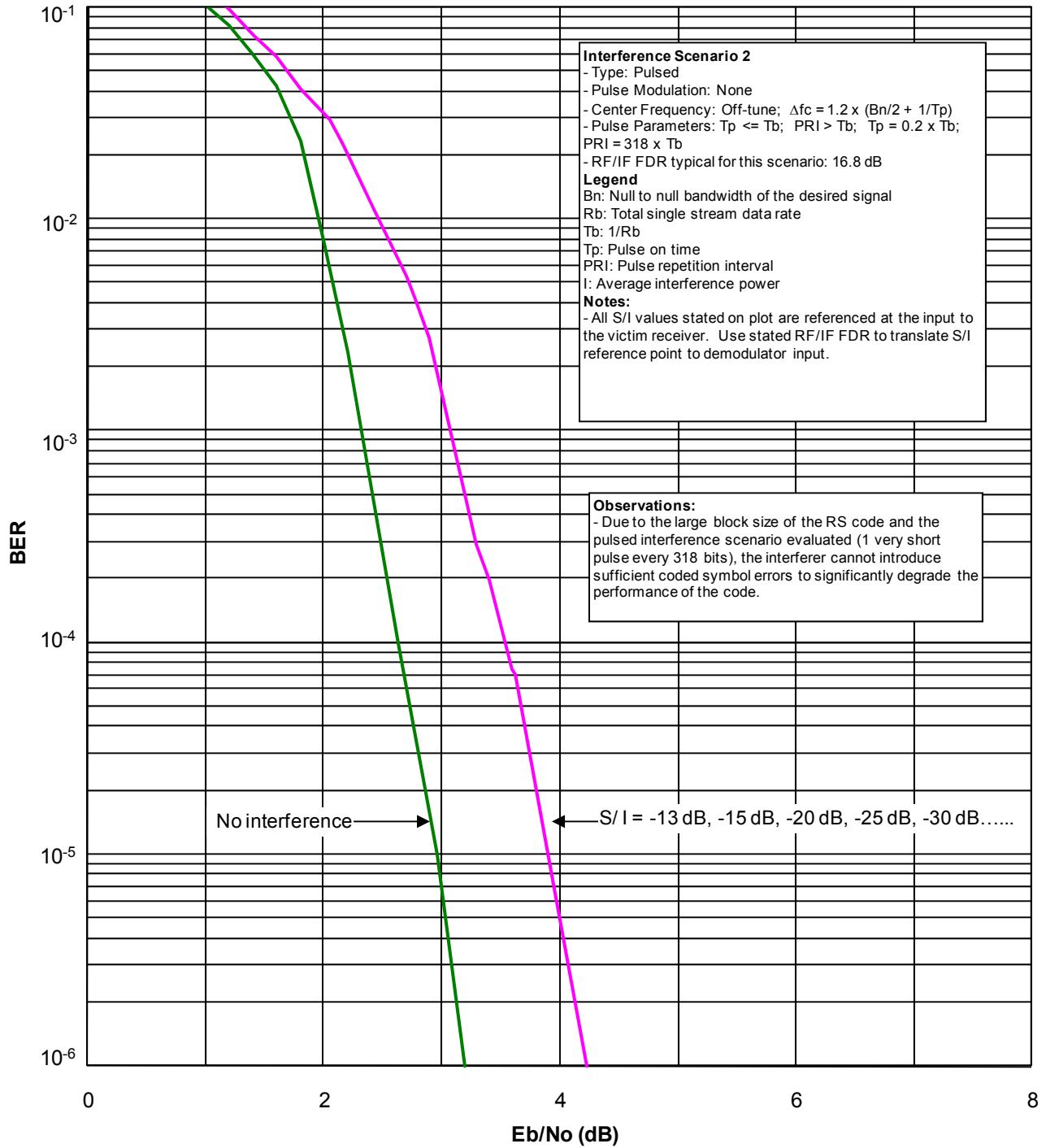

Figure 7.9-8. BER vs. E_b/N_o Curves for ((223,255) RS + rate 1/2 convolution) Coded PSK Receiver ($M = 4$) with Off-Tune Pulsed Interference Scenario 2

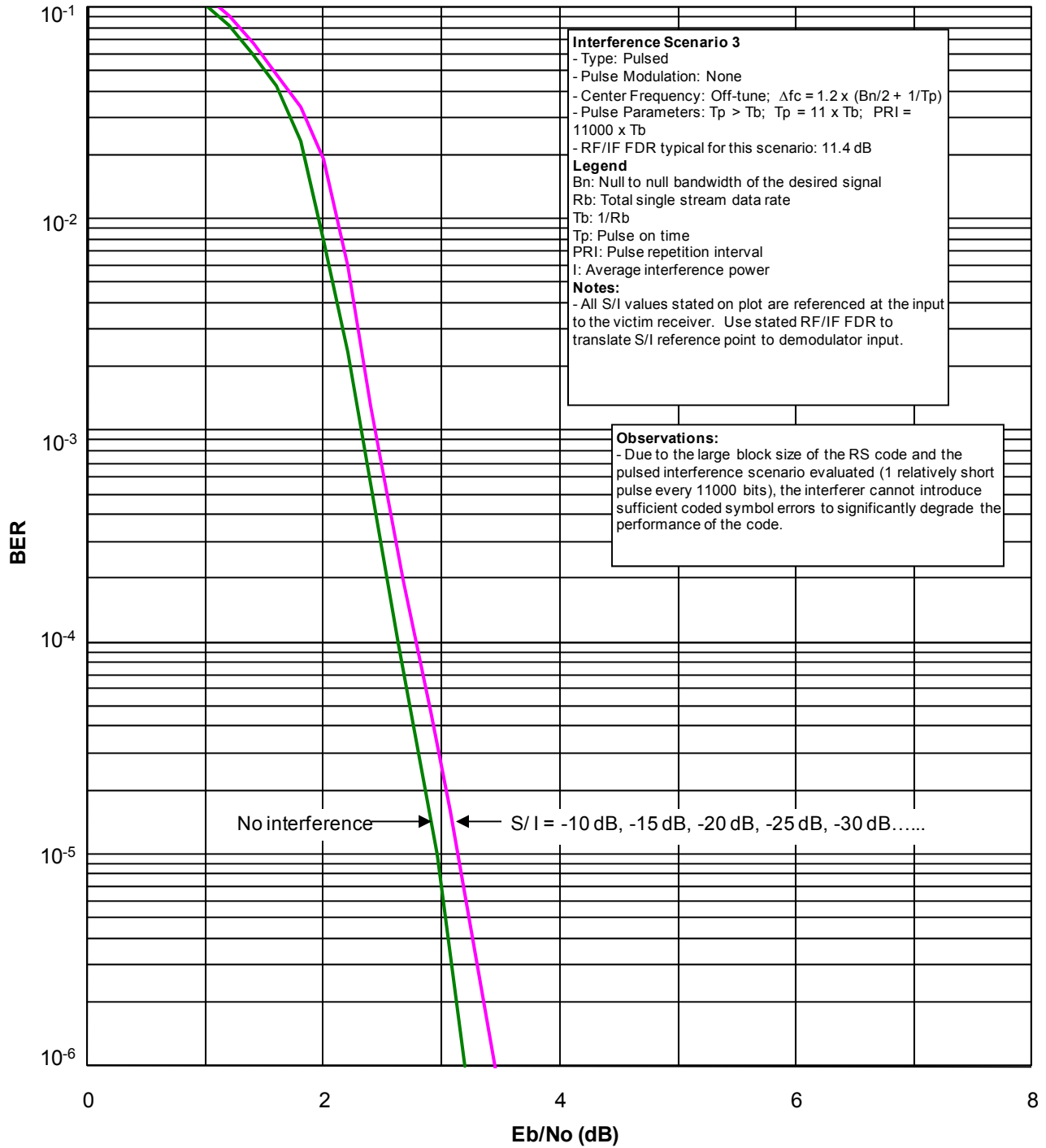

Figure 7.9-9. BER vs. E_b/N_o Curves for ((223,255) RS + rate 1/2 convolution) Coded PSK Receiver ($M = 4$) with Off-Tune Pulsed Interference Scenario 3

7.10 TURBO CONVOLUTIONAL CODES

7.10.1 Description

Turbo codes are a class of high performance error correction codes proposed in 1993 by Berrou and Glavieux.²⁰ Such codes have been shown to approach the Shannon limit. This remarkable error correction capacity has made turbo codes attractive to high data rate applications which often require additional coding gain to maintain the link performance with limited power. Turbo codes are essentially concatenated codes (block codes or convolutional codes) with an interleaver between each component. Turbo Convolutional Codes (TCC) consist of two or more convolutional encoders that can be concatenated either serially or in parallel. Although both Parallel Concatenated Convolutional Codes (PCCC) and Serial Concatenated Convolutional Codes are of great interest, only PCCC performance will be addressed in this Handbook as it is found in many popular communication systems such as 3G. The Turbo coding and decoding technique is briefly described here. Figure 7.10-1 shows an 8-state parallel convolutional code with rate 1/3 as described in the 3G Partnership Project standard.

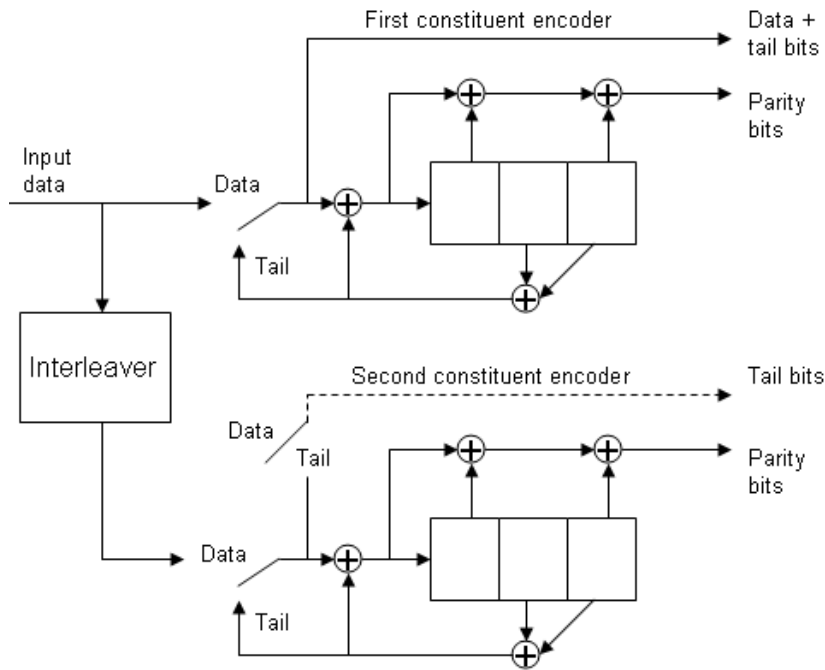

Figure 7.10-1. 1/3 PCCC Encoder

The rate 1/3 is obtained by concatenating two rate 1/2 Recursive Systematic Convolutional (RSC) codes. Since both encoders are rate 1/2, each has two code tap connections. These code tap connections are $G_1 = 1011$ and $G_2 = 1101$. G_1 and G_2 define the possible trellis transitions in response to a +1 or -1. The data bit stream goes into the first encoder which, in turn, outputs a parity bit for each incoming systematic bit (information bit). Both systematic and parity bits are sent across the channel. The input data also goes into the second encoder after being scrambled by the interleaver. The second encoder produces another set of parity bits and transmits them. The

²⁰ C. Berrou, A. Glavieux, P. Thitimajshima. *Near-Shannon Limit Error – Correcting Coding and Decoding: Turbo Codes*. ICC, pp 1064-1070. 1993.

interleaved input bits are not sent across the channel since they can be generated at the receiving end. The purpose of the interleaver is to provide an uncorrelated version of the information bit sequence to each RSC encoder, resulting in parity bits from each RSC encoder that are independent.

For data sequences of length L , the PCCC encoder produces a new block size of length $3L$ containing the systematic bits and the parity bits from encoder 1 and 2. Hence, the overall turbo code rate is $1/3$.

Note that tail bits are appended to the systematic bits and parity bits to ensure that each data sequence ends at state 0. This is a necessary condition to ensure efficient decoding.

7.10.2 Decoding of Turbo Convolutional Codes

Iterative methods are used for turbo decoders. The Maximum A-Posteriori (MAP) algorithm is commonly used iteratively as an optimum bit-by-bit algorithm. Unlike the Viterbi decoding algorithms which maximize the probability of the sequence, MAP maximizes the bit probabilities at each time. The algorithm requires the whole sequence to be received in order to proceed with calculating the forward, backward and transition metrics. Since tail bits were appended to the convolutional sequence, the starting and ending points of the sequence are known. A cumulative metric can then be obtained each time a decision needs to be made about a bit +1 or -1.

The L-values of a +1 bit are given by the following equation:²¹

$$L(u_k) = [L^e(u_k) + L_c \cdot y_k^{1,s}] + \log \frac{\sum_{u^+} \tilde{\alpha}_{k-1}(s') \cdot \tilde{\beta}_k(s) \cdot \gamma_k^e(s', s)}{\sum_{u^-} \tilde{\alpha}_{k-1}(s') \cdot \tilde{\beta}_k(s) \cdot \gamma_k^e(s', s)} \quad (7-13)$$

where α , β , and γ are the forward, backward, and transition metrics, respectively. L_c is the L-value of the measure of the channel S/N. The logarithm expression is called the extrinsic L-value. $L^e(u_k)$ is the a-priori information about bit u_k .

²¹ Charan Langton. *Turbo Decoding Using the MAP Algorithm Part 2. Intuitive Guide to Principles of Communications*. 2006.

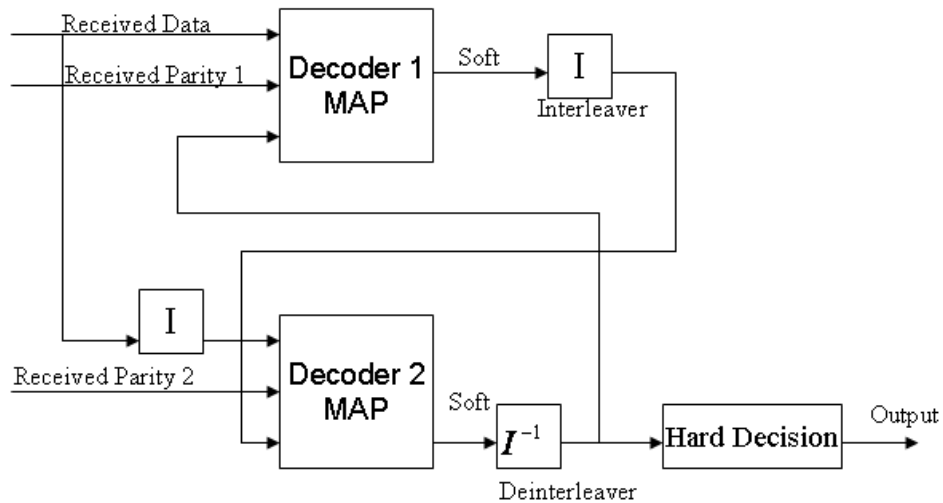

Figure 7.10-2. Iterative Decoding using MAP Algorithm

Figure 7.10-2 shows the typical process of iterative decoding for turbo codes. Decoder 1 outputs its initial guess (soft output) and this becomes the extrinsic value input to decoder 2. The process goes on until a fixed number of iterations are reached.

Figure 7.10-3 shows BER curves for a TCC coded PSK receiver ($M = 4$) with on-tune broadband AWGN interference. Figure 7.10-4 shows BER curves for a TCC coded PSK receiver ($M = 4$) with on-tune CW interference.

Figures 7.10-5 and 7.10-6 show BER curves for a TCC coded PSK receiver ($M = 4$) with various on-tune pulsed interference scenarios (as annotated on the plots).

Figure 7.10-7 shows BER curves for a TCC coded PSK receiver ($M = 4$) with off-tune pulsed interference scenario (as annotated on the plots).

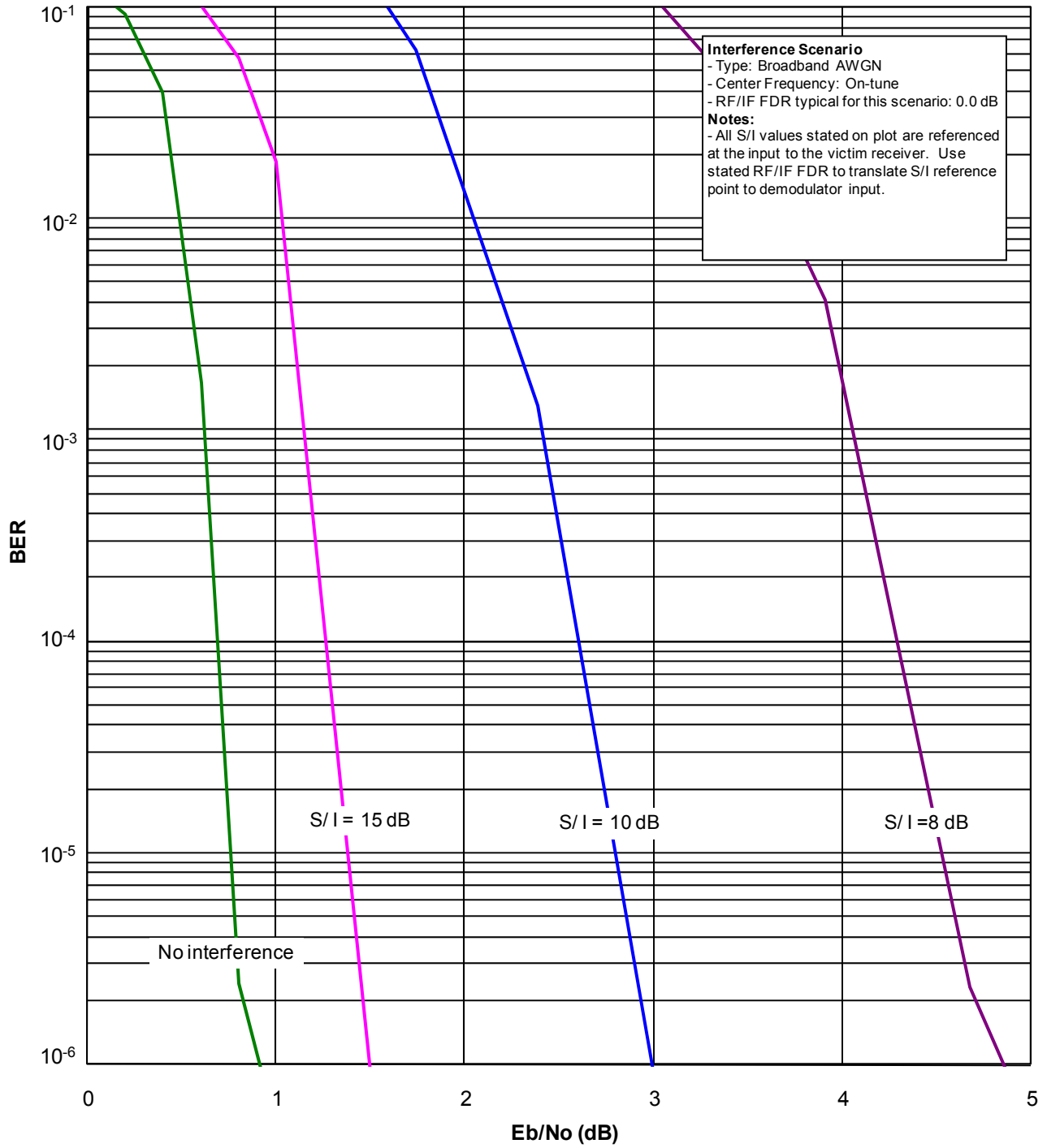

Figure 7.10-3. BER vs. E_b/N_0 Curves for Rate 1/3 TCC Coded QPSK Receiver with On-Tune Broadband AWGN Interference

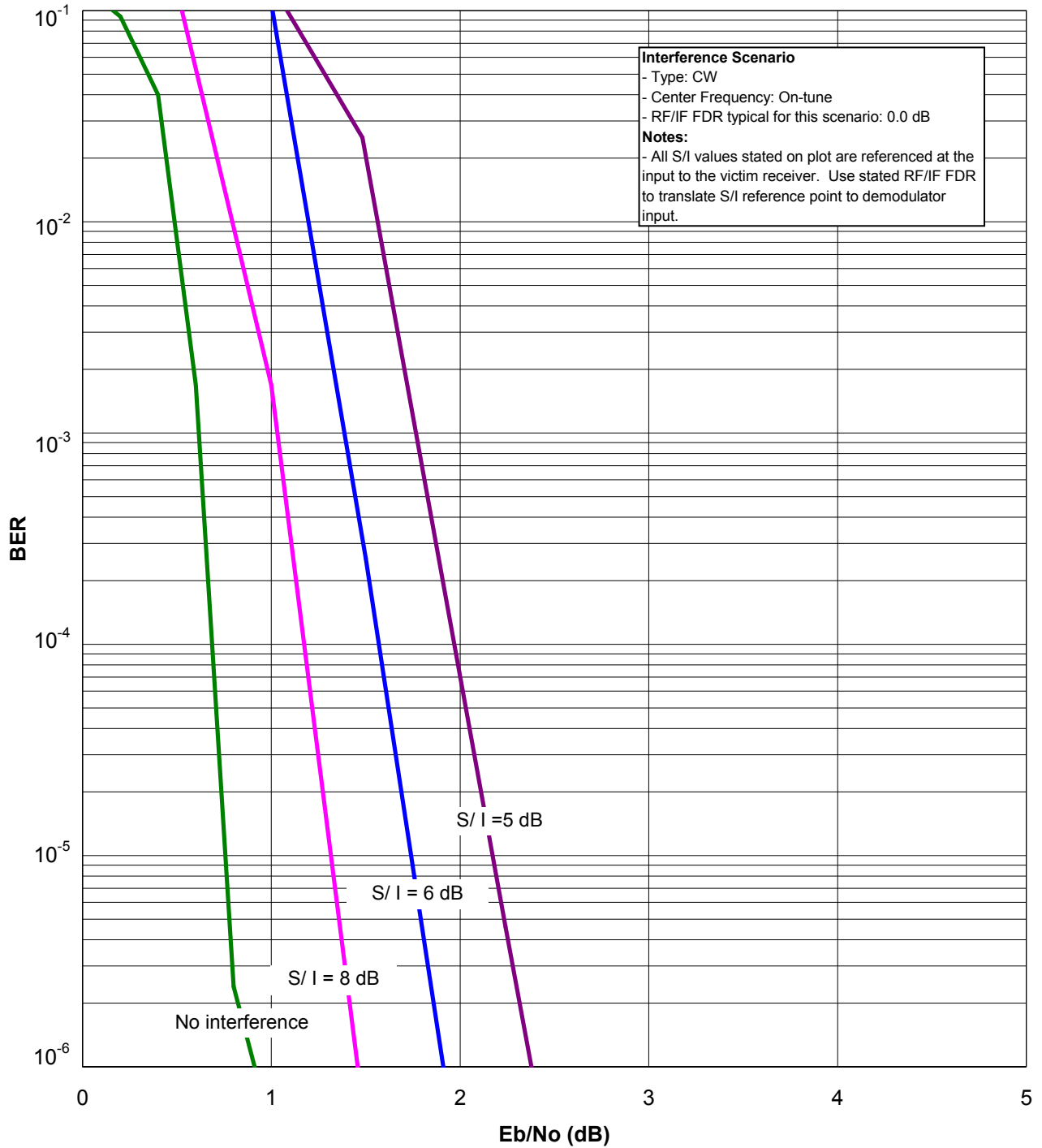

Figure 7.10-4. BER vs. E_b/N_0 Curves for Rate 1/3 TCC Coded PSK Receiver ($M = 4$) with On-Tune CW Interference

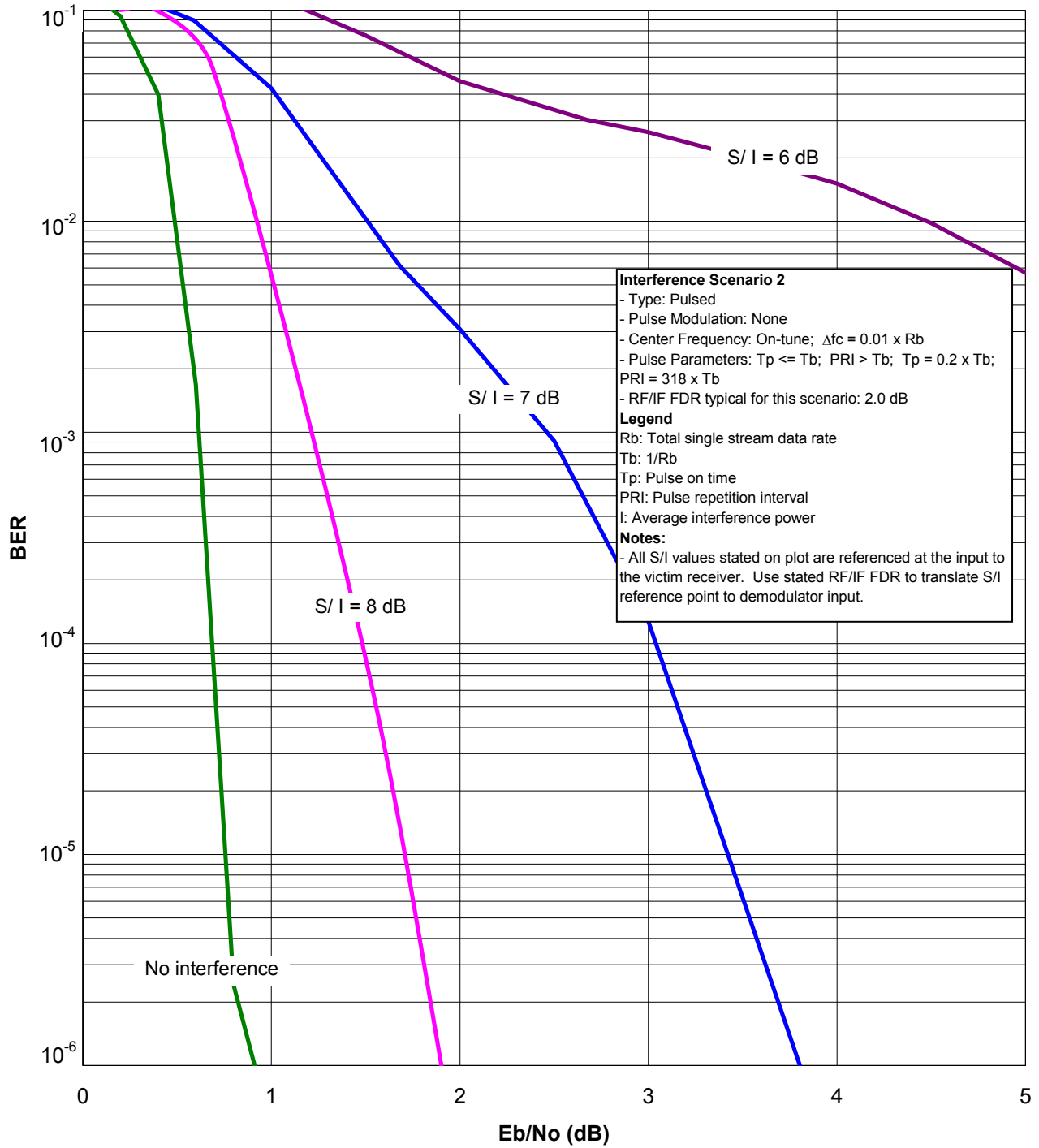

Figure 7.10-5. BER vs. E_b/N_0 Curves for Rate 1/3 TCC Coded PSK Receiver ($M = 4$) with On-Tune Pulsed Interference Scenario 2

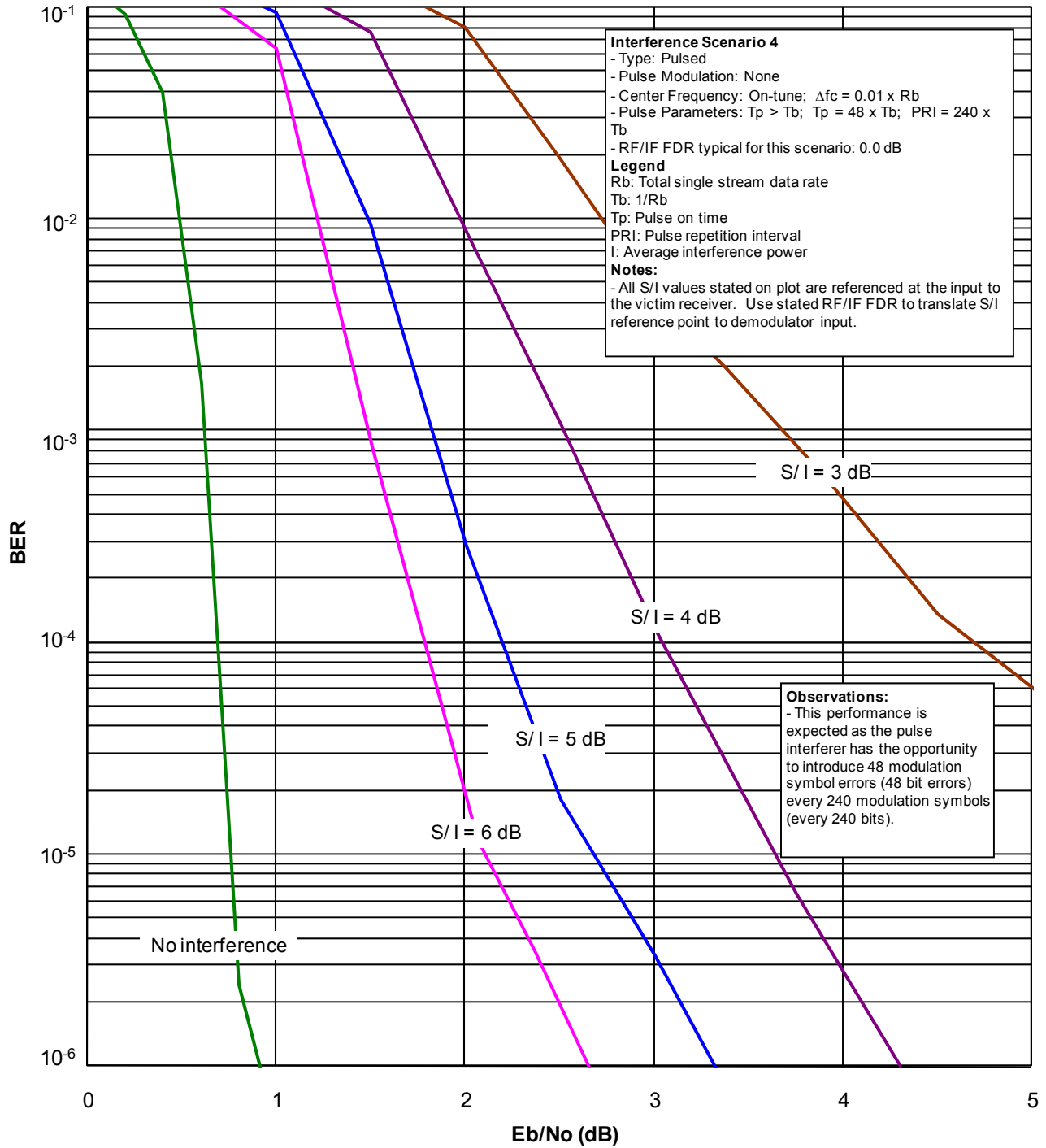

Figure 7.10-6. BER vs. E_b/N_o Curves for Rate 1/3 TCC Coded PSK Receiver ($M = 4$) with On-Tune Pulsed Interference Scenario 4

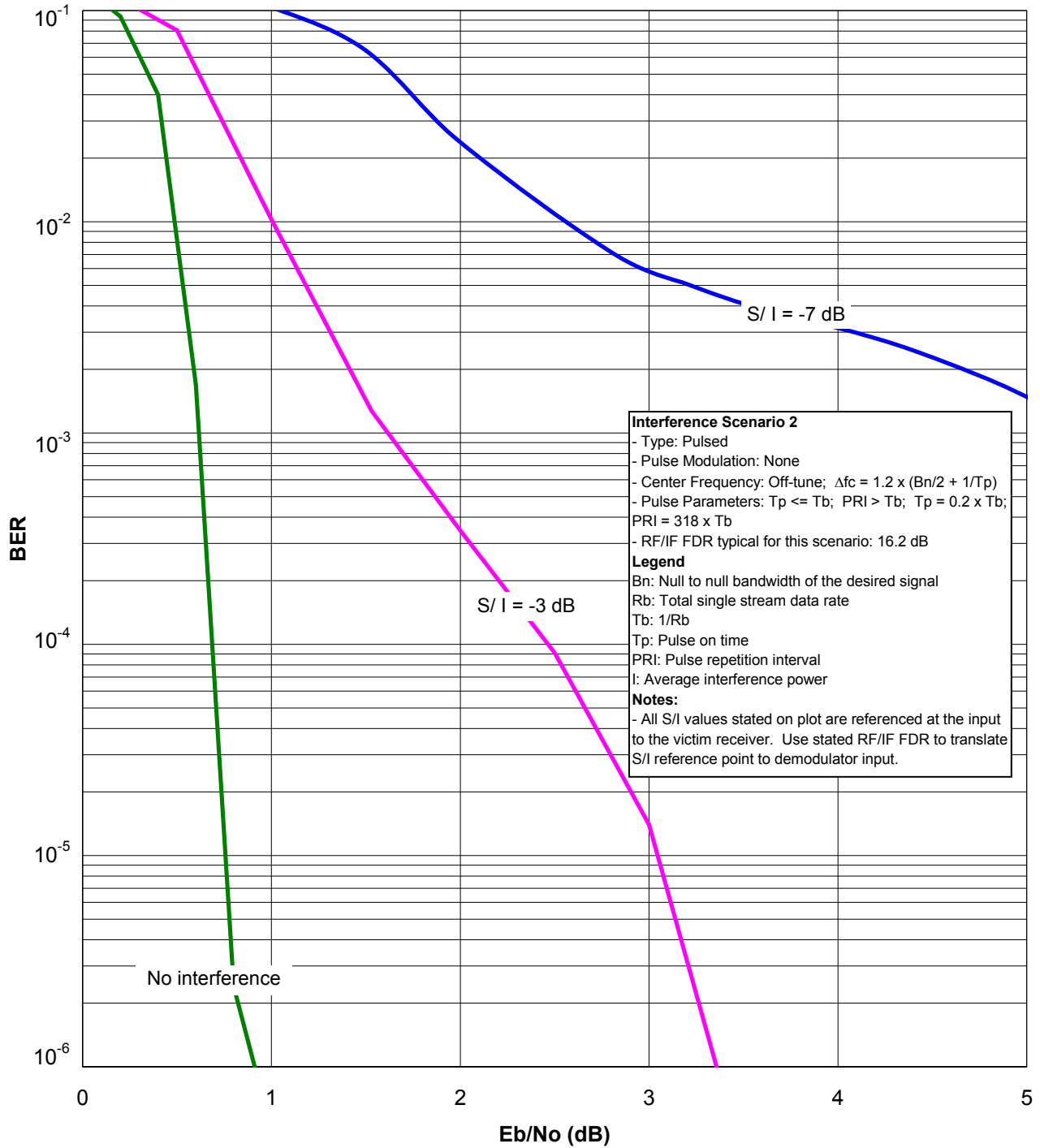

Figure 7.10-7. BER vs. E_b/N_0 Curves for Rate 1/3 TCC Coded PSK Receiver ($M = 4$) with Off-Tune Pulsed Interference Scenario 2

7.11 ERASURE CODES

7.11.1 Description

Erasure codes are a class of codes which enable the error correction overhead to be adjusted based on the channel conditions. Erasure codes were originally proposed in 1998 and belong to a class of codes referred to as Fountain codes.

Erasure codes, and to a broader extent Fountain codes, are well suited for erasure channels. Unlike Reed-Solomon codes, erasure codes need not be fixed at a specific code rate.

In this section, a particular erasure code called Luby Transform (LT) is discussed. LT codes are near optimal erasure codes invented by Michael Luby.²² These codes are rateless because there is no limit to the total amount of packets that can be produced for successful recovery.

LT Encoder

Encoding of LT codes is a process that follows two simple steps. The first step is to generate a random number d (degree) from a degree distribution. This distribution is called the ideal Soliton Distribution, and was specifically defined for LT codes.

$$\begin{aligned}\rho(1) &= 1/k \\ \rho(i) &= 1/i(i-1) \quad \forall i \in \{2,3,\dots,k\}\end{aligned}\tag{7-14}$$

The ideal distribution just described works poorly in practice but provides the basis for the development of a better suited distribution called the Robust Soliton Distribution given below.

$$\tau(i) = \begin{cases} \frac{R}{ik} & \text{for } i = 1, \dots, k/R - 1 \\ R \ln(R/\delta)/k & \text{for } i = \frac{k}{R} \\ 0 & \text{for } i = k/\delta + 1, \dots, k \end{cases}\tag{7-15}$$

$$\mu(i) = (\rho(i) + \tau(i)) / \beta\tag{7-16}$$

Once the number d is selected from the Robust Soliton distribution, d distinct input bits are chosen uniformly at random. The encoded (i.e., output) bit value is simply the exclusive or (XOR)-sum of these d bit values. Figure 7.11-1 illustrates the encoding process for LT codes.

²² M. Luby. *LT Codes. Proceeding of Foundations of Computer Science. 2002.*

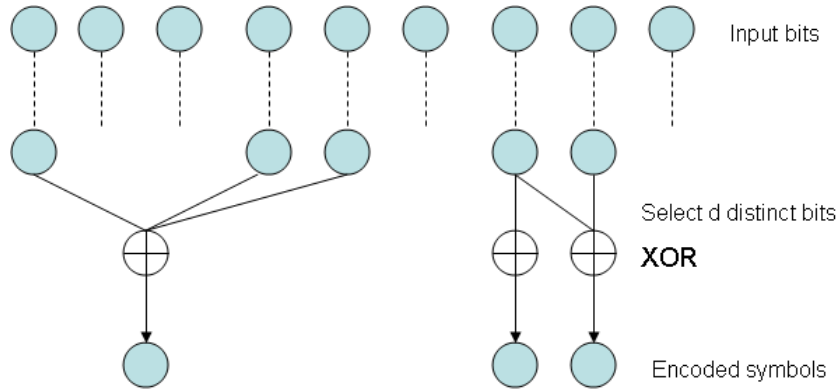

Figure 7.11-1. LT Encoding Process

LT Decoding²³

The decoding process is more complex and is beyond the scope of this Handbook. The unique characteristic of Fountain codes is that knowing which packet was received is not essential, the decoding process is initiated when a sufficient number of packets have been received. The decoding process is based on the fact that an encoded symbol of degree one (i.e., one edge between the encoded symbol and the original bit) can be immediately recovered. Any degree two symbols connected to the same original bit that was just recovered can now be decoded as well. This process goes on until no more degree one symbols remain.

7.11.2 Effect of Interference on Erasure Codes

Erasure codes would typically drop a packet either when an error is detected or if the packet had already been received. Consequently, Erasure code performance is naturally evaluated over erasure channels and is measured in terms of overhead required to recover the original message. Intuitively, it can be predicted that as more errors are detected, more packets will be dropped, therefore requiring more packets to be re-transmitted for complete message recovery. In the presence of a pulsed interferer, it is important to consider the PRI of the signal in predicting the effect on erasure codes.

Consider Figure 7.11-2 below where T_{pack} is the packet period and $R = k/n$ is the code rate of a (n, k) code. If the PRI is assumed to be large (i.e., $\text{PRI} \gg T_{\text{pack}}$), then internal noise would remain the dominant source of error since the pulsed interferer would potentially only affect a few packets over the entire transmission period.

Next consider Figure 7.11-3 where PRI is small (i.e., $\text{PRI} < T_{\text{pack}}$). Depending on the level of interference, a great number of packets could be received with errors. There will be a point where the pulsed interferer will become the dominant source of error as illustrated in Figure 7.11-3.

²³ Ashish Khisti. *Tornado Codes and Luby Transform Codes*. 22 October 2003.

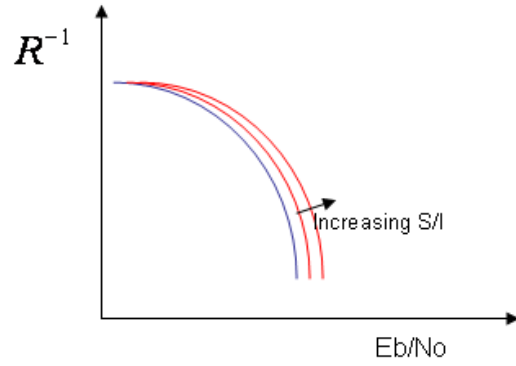

Figure 7.11-2. Notional Plot Illustrating the Effect of a Pulsed Interferer on Erasure Codes with $PRI \gg T_{pack}$

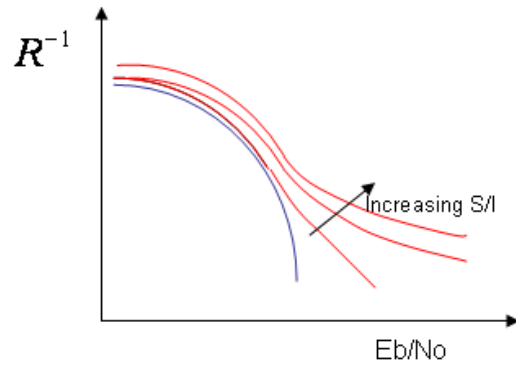

Figure 7.11-3. Notional Plot Illustrating the Effect of a Pulsed Interferer on Erasure Codes with $PRI < T_{pack}$

SECTION 8 - SOURCE DECODER

In a transmitter, the source encoder converts the source information into a sequence of bits at a certain data rate. If the source is analog, an ADC samples and encodes the analog waveform. If the source is digital, the source encoder reformats and retimes the input data if necessary. The output of the source encoder is a sequence of information bits, at the information data rate.

In the receiver, the source decoder converts the information bit sequence to the format required by the user of the receiver. If this format is analog, a DAC will be employed at this stage. The output of the source decoder is the output of the receiver. In general, it will differ somewhat from the original information signal due to noise and interference. This difference can be quantified, and is a measure of the overall system performance.

A DAC, along with its associated ADC, is used in a hybrid communications system. A hybrid system uses digital processing and transmission techniques to communicate analog information. When used to transmit speech, hybrid systems usually provide duplex capability; in such an application the ADC/DAC pair are often combined in a single unit referred to as a CODEC. There are various techniques available for performing the analog-to-digital and digital-to-analog conversion; the particular technique employed has an effect on the fidelity of the reconstructed analog signal as well as the sensitivity of the system to channel-induced bit errors. When transmitting analog information, such as voice or video, over digital systems, data compression techniques are normally used to reduce the required bit rate. Furthermore, the use of companding also helps to reduce the effects of quantization noise on voice communications.

8.1 MULTI-BIT SAMPLING

8.1.1 Description

Pulse-code modulation (PCM) is a straightforward conversion algorithm. The analog waveform is sampled at regularly spaced intervals established by the sampling frequency, and each sample is coded into a k -bit digital word according to its amplitude. Because there are multiple bits associated with each sample, PCM is also called *multi-bit sampling*. The analog waveform is thus represented by a sequence of k -bit digital words. The resulting bit stream is transmitted; channel impairments typically result in a number of errors in the received demodulated bit stream. In the receiver, the DAC decodes the digital words and produces a sequence of samples. Signal conditioning operations such as interpolation and lowpass filtering are then performed on the samples, resulting in a reconstructed analog waveform that should be a close approximation to the original information signal. The block diagram for a PCM ADC and DAC appears in Figure 8.1-1.

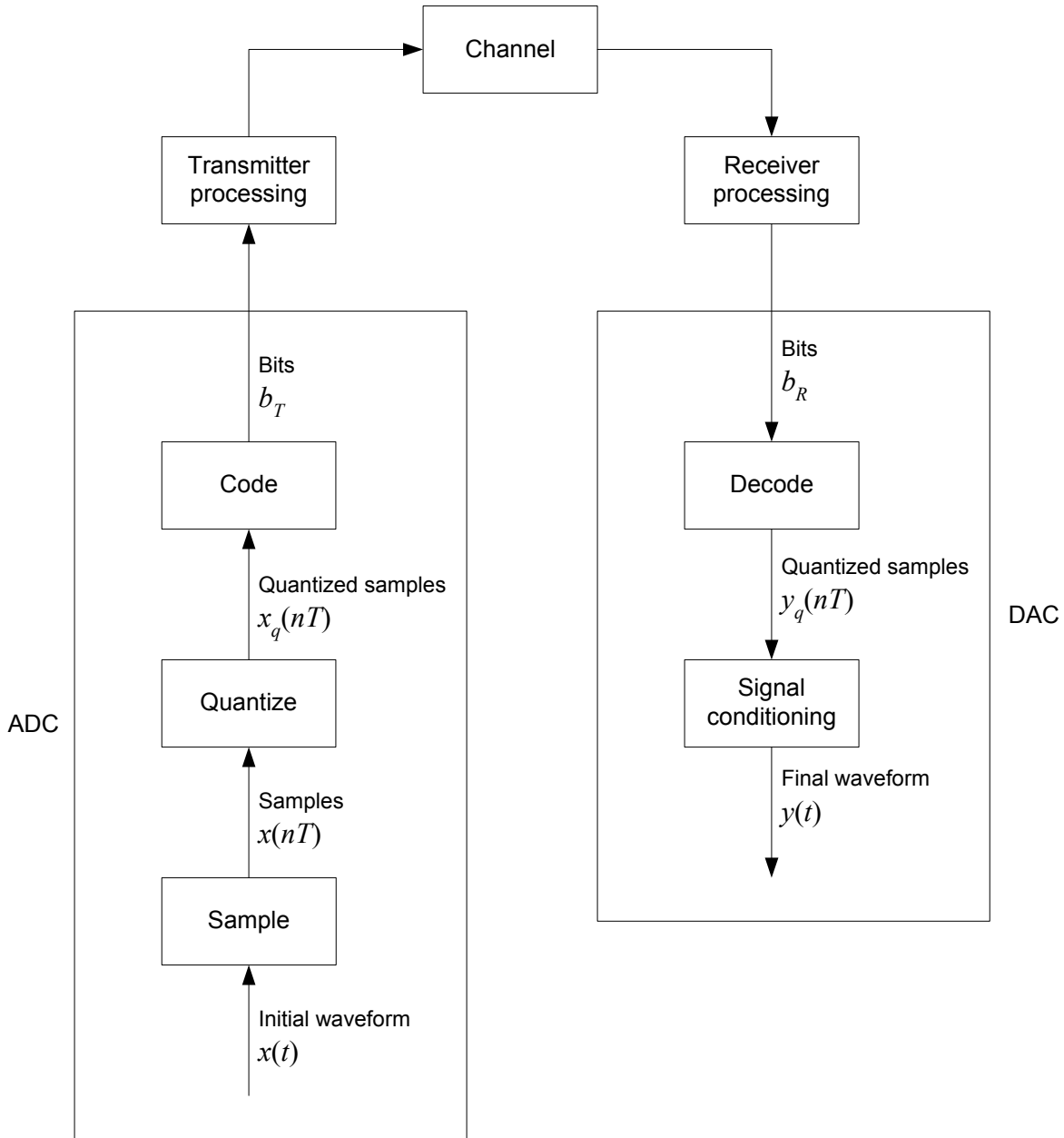

Figure 8.1-1. Block Diagram for PCM ADC and DAC

The input signal to the transmitter is denoted $x(t)$ in Figure 8.1-1. The Sample operation produces a sample sequence denoted $x(nT)$, where T is the sampling interval and $n = 1, 2, \dots, L$. These samples are then quantized. For k -bit PCM, the number of quantization levels is 2^k . Each sample $x(nT)$ is replaced by the nearest quantization level $x_q(nT)$. The Code operation then replaces each quantized sample with a sequence of k bits. For example, in a 6-bit ADC there are $2^6 = 64$ quantization levels. These levels in decimal form are 0, 1, 2, ..., 63, where the 0 value represents the minimum signal and the 63 value represents the maximum signal. If a particular sample is quantized to the decimal level 5, then the Code operation replaces the decimal level 5 by its binary form 000101. Thus, a sequence of L samples becomes a sequence b_T of kL bits.

Then the bit sequence is processed in the transmitter to create the channel waveform. This processing includes modulation and perhaps error correction coding and spreading. The channel

waveform travels across the channel to the receiver, where it is processed to recover the received bit sequence b_R . The receiver processing includes demodulation and perhaps error correction decoding and despreading. If the transmission is error-free, then $b_R = b_T$.

When the received bit stream is decoded, the result is again a sequence of quantized samples. This sequence is denoted $y_q(nT)$ in Figure 8.1-1. If $b_R = b_T$, then $y_q(nT) = x_q(nT)$. Then the sequence of samples is conditioned (e.g., interpolated and lowpass filtered) to convert it to a continuous analog signal, denoted $y(t)$ in Figure 8.1-1. In good conditions, $y(t) \approx x(t)$.

Note that even in the absence of bit errors, the DAC signal conditioning block may not reproduce $x(t)$ with perfect fidelity, because of information loss in the quantization process. The resulting distortion, i.e., the difference between $x(t)$ and $y(t)$ in error-free transmission, is referred to as *quantization noise* and is a performance-limiting factor in any hybrid communications system. It should be noted that quantization noise can be made arbitrarily small by increasing the number of bits per sample. The trade-off, of course, is an increase in data rate and required bandwidth.

8.1.2 Output Signal-to-Noise

A fundamental assumption in a performance degradation analysis of hybrid communications systems is that the noise due to quantization and the noise due to channel-induced bit errors are additive. It is appropriate, therefore, to specify a source decoder transfer function that gives output S/N (including both types of noise) as a function of input BER.

The source decoder performance curves for a multi-bit (PCM) decoder²⁴ are given in Figure 8.1-2. The S/N vs. BER relationship is shown for k -bit PCM with $k = 4, 5, 6, 7,$ and 8 . The sampling rate in each case is 8 kHz.

²⁴L. Rabiner and R. Schaefer. *Digital Processing of Speech Signals*. Prentice-Hall, Inc., Englewood Cliffs, NJ. 1978.

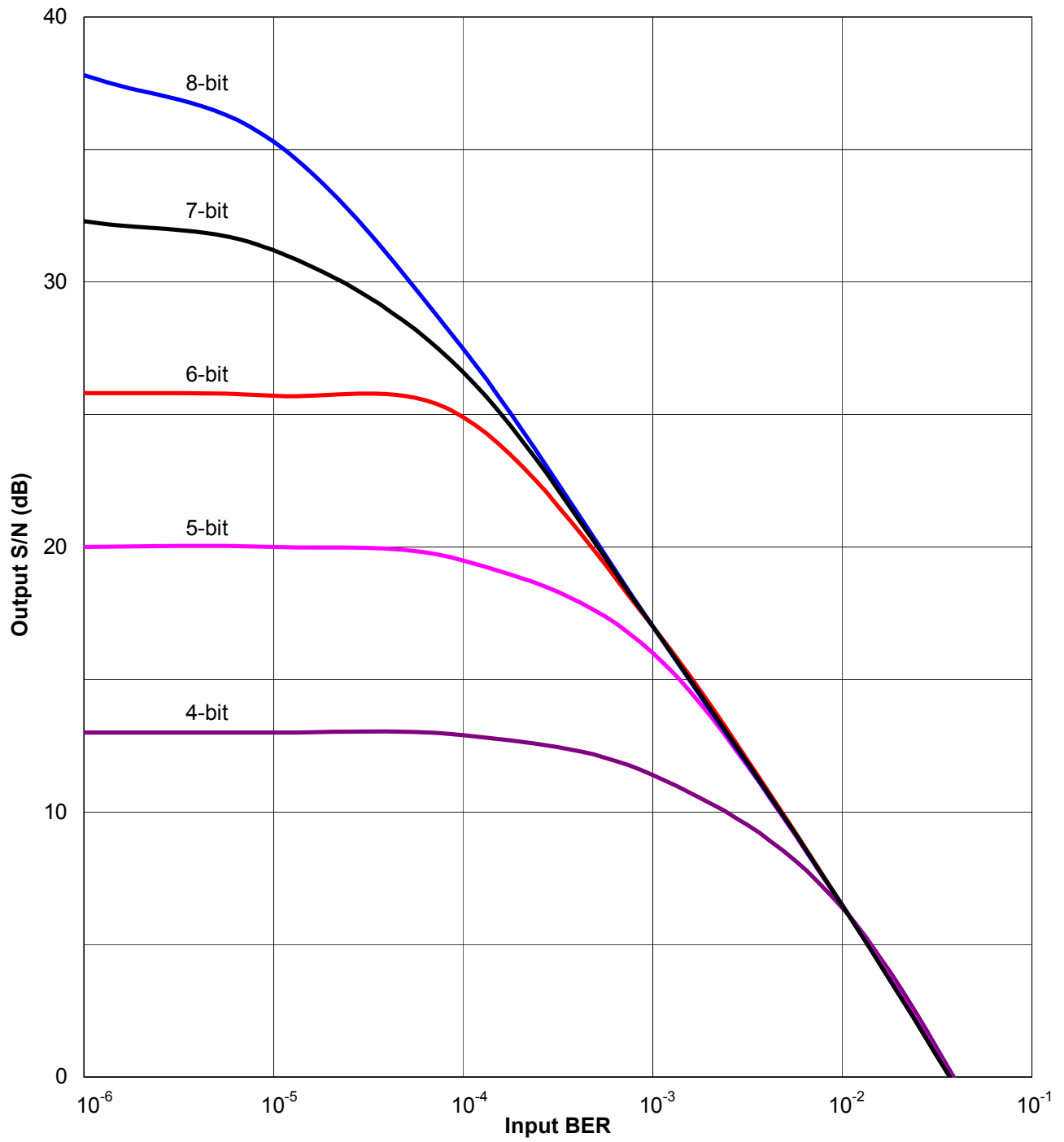

Figure 8.1-2. Output S/N vs. Input BER for PCM DAC

8.2 SINGLE-BIT SAMPLING

8.2.1 Description

Differential PCM (DPCM) is a signal conversion scheme similar to PCM in that the ADC samples an analog waveform. Rather than sampling, quantizing, and coding the actual input waveform, the ADC performs these operations on the difference between the waveform and an estimate of the waveform. A DPCM encoder is shown in Figure 8.2-1. The input waveform, estimate of the waveform, and difference signal are denoted $x(t)$, $x_E(t)$, and $d(t)$, respectively. The estimation algorithm is designed so that the estimate $x_E(t)$ closely resembles the actual waveform $x(t)$. The difference signal $d(t)$, therefore, tends to be relatively low in amplitude. Consequently, the difference signal can be coded with relatively few bits per sample, resulting in a more efficient system than strict PCM coding. Also, the estimation algorithm itself can serve as the receiver DAC.

Perhaps the simplest DPCM estimation algorithm involves a single-sample delay. The underlying assumption is that the input waveform varies slowly enough so that the present sample is very close to the previous sample. Delta Modulation (DM) is an example of such a technique, with the further simplifying assumption that the difference signal can be adequately represented by a one-bit code. In other words, a DM ADC simply transmits a single bit according to whether the input waveform sample has made a positive or negative excursion with respect to the previous sample. If no difference is detected, the system will typically idle, transmitting a sequence of alternating 1-bits and 0-bits. This technique is also called *single-bit sampling* or *oversampling* (because the sampling rate must be high to ensure that the waveform varies slowly between samples).

Signal conversion algorithms involving estimation techniques, such as DPCM, often permit the estimation procedure to adapt in response to certain conditions. If the DPCM difference signal exceeds some specified value, for example, the estimation procedure may change in such a way as to reduce the difference in the future. This technique has been successfully applied to DM systems resulting in what are known as Adaptive DM (ADM) systems. One variation of ADM that is currently popular, owing to its simplicity and resistance to channel errors, is Continuously Variable Slope Delta (CVSD) modulation. CVSD systems are capable of adequate performance at BERs as high as 10%. For this reason, CVSD systems are appropriate for use in communications applications where systems must function properly under adverse channel conditions. The CVSD algorithm and the other signal conversion techniques referred to in this section are described more thoroughly in many texts.²⁵

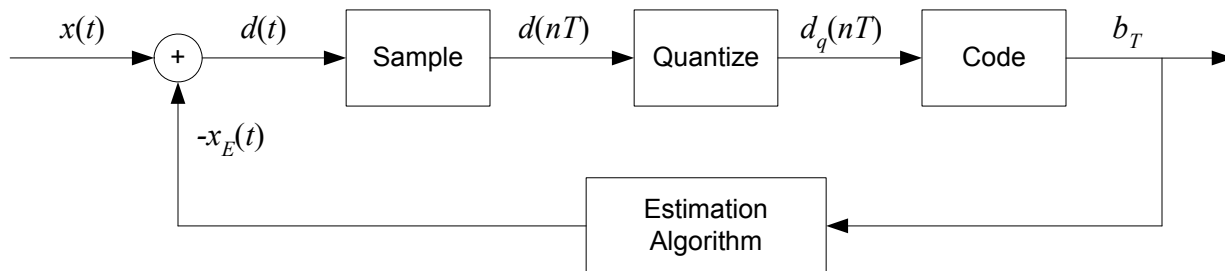

Figure 8.2-1. Block Diagram for DPCM Encoder

²⁵ N. Jayant and P. Noll. *Digital Coding of Waveforms*. Prentice-Hall, Inc., Englewood Cliffs, NJ. 1984.

8.2.2 Output Signal-to-Noise Ratio

Figure 8.2-2 shows an output S/N vs. input BER curve for 16-kbit CVSD.²⁶

Comparing the curve in Figure 8.2-2 with the curves in Figure 8.1-2 shows that 6-, 7-, and 8-bit PCM outperform CVSD at low values of BER, while CVSD outperforms PCM when the BER is large.

It should be noted that CVSD achieves this performance at a data rate between one-fourth and one-third the data rate of the comparable PCM system.

²⁶ E. Harras and J. Preusse. *Communication Performance of CVSD at 16/32 Kilobits/second*, Communications-Electronics System Integration Office. US Army Electronics Command, Fort Monmouth, NJ. 1974.

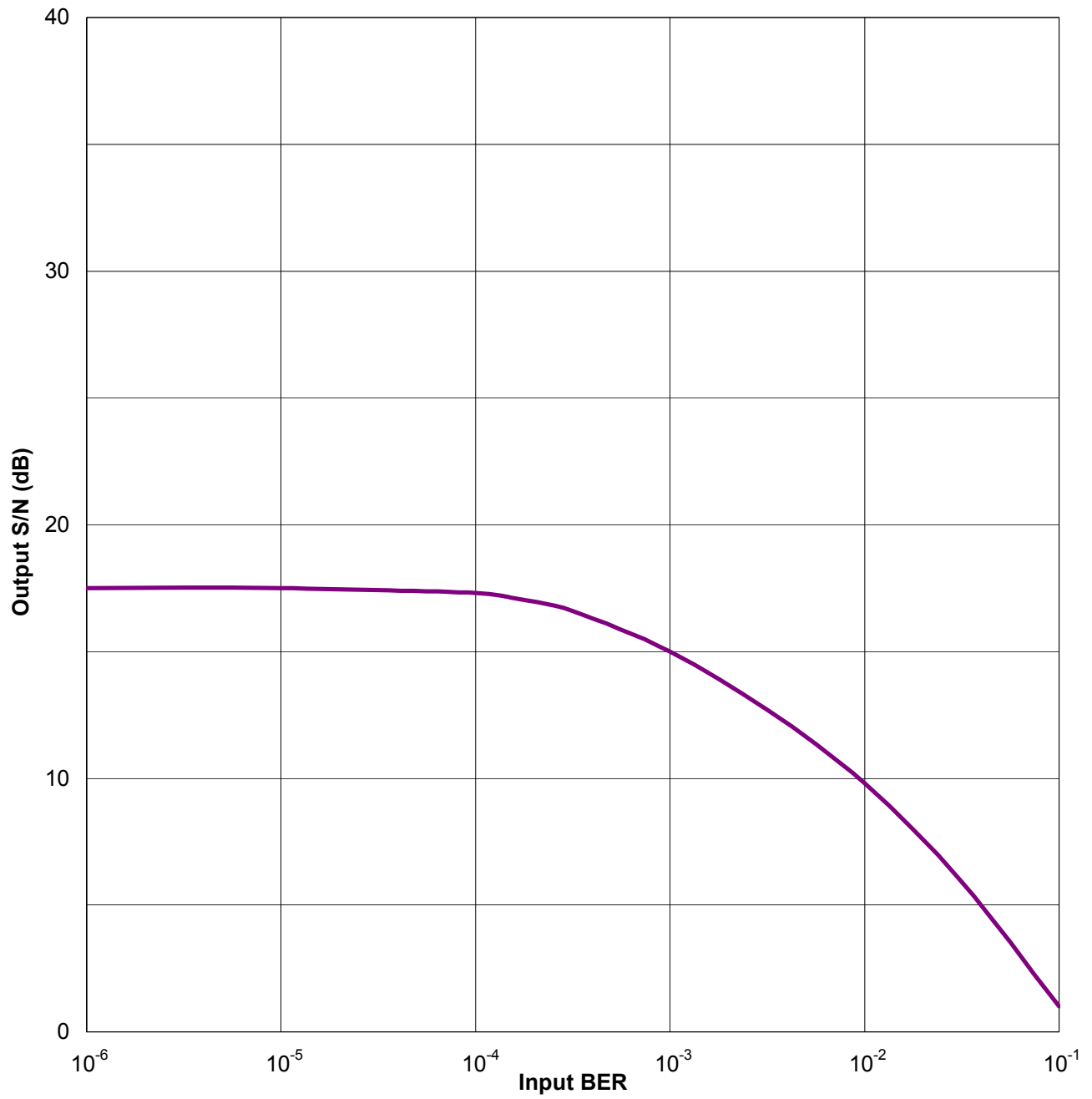

Figure 8.2-2. Output S/N vs. Input BER for 16-kbit CVSD

This page intentionally left blank.

SECTION 9 - SAMPLE RECEIVER ANALYSIS PROBLEMS

This section provides several examples on the use of this Handbook to perform a receiver analysis. The examples follow Section 2.4.5 which describes the step by step process for performing the receiver analysis.

9.1 RECEIVER PERFORMANCE ANALYSIS EXAMPLE 1

A two-way radio system is being planned to support digital (speech) communications. BPSK modulation will be used. There is some flexibility in the system design regarding transmitter power and whether or not FEC is used. The S/N of the output voice signal is required to be greater than 15 dB.

An RF analysis is required to

- Estimate input signal requirements without FEC
- Estimate input signal requirements with FEC
- Compare the two implementations

9.1.1 Approach

The following approach will be taken:

- Model each system
- Work backwards to calculate input signal requirement for each system
- Compare the two implementations

9.1.2 Models

The characteristics of System 1 are as follows:

- DAC: 48 kbit PCM, 8000 samples/s at 6 bits/sample
- FEC: none
- Demodulator: BPSK
- IF Bandwidth: 100 kHz

The characteristics of System 2 are as follows:

- DAC: 48 kbit PCM, 8000 samples/s at 6 bits/sample
- FEC: Extended Golay (24, 12) soft-decision
- Demodulator: BPSK
- IF Bandwidth: 200 kHz

System 2 requires twice the bandwidth because the coded data rate is twice the uncoded data rate.

9.1.3 Calculate Input Signal Requirement for System 1

The following analysis steps apply for System 1:

- A catalog look-up approach can be used.
- Figures 6.6-1 and 8.1-2 are applicable for this communications system scenario.
- There is no interference – the analysis will consider only the effects of noise.
- The required performance measure is a minimum output S/N of 15 dB.
- Using the Input BER vs. Output S/N curve for 48 kbit PCM (Figure 8.1-2), an output S/N = 15 requires approximately BER = 10^{-3} at the input.
- Using the uncoded BPSK demodulator curve (Figure 6.6-1), an output BER = 10^{-3} requires an input $E_b/N_0 = 7$ dB. Using Equation 6-8 with a 100 kHz bandwidth and a 48 kbps bit rate, the corresponding S/N is 3.8 dB.

9.1.4 Calculate Input Signal Requirement for System 2

The following analysis steps apply for System 2:

- A catalog look-up approach can be used.
- Figures 6.6-1, 8.1-2, and 7.5-7 are applicable for this communications system scenario.
- There is no interference – the analysis will consider only the effects of noise.
- The required performance measure is a minimum output S/N of 15 dB.
- Using the Input BER vs. Output S/N curve for 48 kbit PCM (Figure 8.1-2), an output S/N = 15 requires approximately BER = 10^{-3} at the input.
- Using the BER vs. E_b/N_0 curve for the soft-decision Golay decoder (Figure 7.5-7), for PSK an output BER = 10^{-3} requires an input $E_b/N_0 = 3$ dB. Using Equation 6-8 with a 200 kHz bandwidth and a 48 kbps uncoded bit rate, the corresponding S/N is 2.8 dB.

9.1.5 Comparing the Two Implementations

System 2 requires 4 dB less E_b/N_0 than System 1 to achieve the required output. However, the bandwidth of System 2 is twice that of System 1, so it will have twice the noise (i.e., 3 dB more). Thus, System 2 has a 1-dB power advantage. It can transmit slightly less power than System 1 and achieve the same performance goal. If transmitting at the same power level, System 2 will have a slightly greater communications range, at the expense of greater receiver complexity. An additional advantage of System 2 is that it will be less susceptible to performance degradation in a noise plus interference channel due to the added protection of a FEC code.

9.2 RECEIVER PERFORMANCE ANALYSIS EXAMPLE 2

This example has wider scope than the previous example. To illustrate the context in which a receiver analysis frequently occurs, a realistic problem is presented and solved with a combination of techniques, including techniques from Sections 3 and 5 of this Handbook.

A two-way FM voice radio system is being planned to support communications between a mobile radio and a fixed base station. The operational area extends to 100 km from the base station. The

preferred operating frequency is at or near 160 MHz. The base station transmitter has 5 W of power and employs an omnidirectional antenna with 2 dBi of gain. The mobile antenna has not been specified, pending the outcome of the analysis. The system will be operated in an area with a moderate density of commercial and industrial development. In this area, it is known that there is a digital communications link operating in the same frequency band.

Focusing on the performance of the mobile receiver, an RF analysis is required to

- Validate the basic design decisions
- Determine the optimum mobile antenna
- Minimize the impact of the interfering digital communications link

9.2.1 Approach

The following approach will be taken:

- Summarize the operating environment
- Specify the equipment characteristics
- Specify or summarize the required performance goals
- Use link-budget analysis to estimate the received-signal power
- Utilize this Handbook to estimate the system performance and answer the questions about the antenna and the interference. A catalog look-up approach will form the basis of the analysis.

9.2.2 Operating Environment

- Size: Radius of mobility is 100 km, so the maximum distance for the desired link is 100,000 meters.
- Type: “Moderate density of commercial and industrial development” indicates the possibility of signal fading. It will be assumed that previous measurements at a similar site determined that a 20-dB fade margin is required.
- Interference: Digital (FSK) modulation, operating in a single 25-kHz channel in the VHF band, at 5 W.

9.2.3 Equipment Characteristics (for the Desired Signal)

It is assumed that the following information has been determined:

- Transmitter power: $5 \text{ W} = 5000 \text{ mW}$, $10 \log(5000) = 37 \text{ dBm}$
- Base station antenna: omni, gain = 2 dBi
- Mobile antenna: unspecified
- Modulation: FM voice, frequency deviation $\pm 5 \text{ kHz}$
- Receiver IF bandwidth: 16 kHz
- Receiver Noise Figure: 4 dB

- Adjacent Channel Rejection: 65 dB
- Frequency: VHF band, preferably at or near 160 MHz
- Receiver sensitivity: 0.3 μ V for output S/N = 12 dB

9.2.4 Required Performance

The required performance is specified in terms of the AI. The interpretation of AI is subjective and is generally context-dependent. For this example, the following interpretation is assumed:

$AI > 0.9$	Good
$0.9 \geq AI > 0.7$	Adequate intelligibility
$0.7 \geq AI > 0.44$	Marginal intelligibility
$AI \leq 0.44$	Unacceptably poor intelligibility

Note: The receiver sensitivity can also be used to evaluate performance, but it does not address signal intelligibility and it does not address non-noise-like interference.

9.2.5 Received Signal Power Calculation

Equation 2-1 is used to estimate the minimum received-signal power. The distance is assumed to be the maximum operating distance of 100 km. The mobile antenna is unspecified at this point, so its gain is arbitrarily set to 0 dBi.

$$\begin{aligned}
 P_R &= P_T + G_T + G_R - 20 \log(d) - 20 \log(f) + 27.6 \\
 &= 37 + 2 + 0 - 20 \log(100,000) - 20 \log(160) + 27.6 \\
 &= -77 \text{ dBm}
 \end{aligned}$$

9.2.6 Comparison of Received-Signal Power With Receiver Sensitivity

The receiver sensitivity is 0.3 μ V (3×10^{-7} V). The following equation is used to convert this quantity to power:

$$P = 10 \log\left(\frac{V_{rms}^2}{R}\right) + 30 = 10 \log\left(\frac{9 \cdot 10^{-14}}{50}\right) + 30 = -117 \text{ dBm}$$

where

P	=	signal power, in dBm
V_{rms}	=	RMS voltage of signal, in V
R	=	antenna impedance (50 ohms)

Thus a received-signal power of -117 dBm is required to produce an output S/N of 12 dB. The estimated minimum received-signal power is -77 dBm, which provides a considerable margin – more than enough to accommodate the 20-dB fade margin. This initial result is encouraging, but the Handbook will be used to develop a more complete picture that includes the noise and interference.

9.2.7 Noise Calculation

The receiver noise power referenced to the receiver input is given by:

$$\begin{aligned} N &= F_R - 144 + 10 \log(B_R) \\ &= 4 - 144 + 10 \log(16) \\ &= -128 \text{ dBm} \end{aligned}$$

where

$$\begin{aligned} F_R &= \text{receiver noise figure, in dB} \\ B_R &= \text{receiver IF bandwidth, in kHz} \end{aligned}$$

In this equation, the term -144 dBm/kHz is the thermal noise power density at standard room temperature (290 K). Depending on the frequency range of operation, it may be appropriate in some cases to include an additional factor for man-made noise contributions.

9.2.8 Interference Calculation

The worst-case assumption is that the interference is on tune; i.e., in the desired-signal channel. The interfering signal bandwidth is about the same as the desired signal bandwidth since they both occupy a 25-kHz channel. In this case, Section 3 indicates that there is no FDR.

The undesired received-signal power can be estimated just like the desired signal by means of Equation 2-1. However, both the desired and the undesired received-signal powers would have to be calculated at every point within the radius of mobility. The calculation of desired signal power that was done previously for maximum distance does not necessarily give the worst-case S/I. The S/I will vary as the mobile moves throughout the area. If the location of the interference were known, it would be possible to use propagation-modeling software to compute the area coverage in terms of S/I. Instead of performing those detailed calculations, the interference effects will simply be characterized here in general terms by using the Handbook transfer functions.

The relevant catalog look-up data is provided in Figure 5.5-3, which displays multiple AI vs. S/N curves, with FSK interference. One curve is for the baseline case with no interference. Each of the other curves is for a particular S/I value. Because the minimum received-signal power is -77 dBm and noise power is -128 dBm, the worst-case S/N is $(-77) - (-128) = 51$ dB. Including the 20-dB fade margin, the worst-case S/N is 31 dB.

It is clear from the plot that, in the absence of interference, this is more than enough S/N for proper operation. Since noise is not a problem, the operation is said to be interference-limited. The curves show that an S/I of less than about 12 dB but greater than 6 dB puts the system in the adequate range ($0.7 < AI \leq 0.9$), and an S/I of less than about 6 dB puts the system in the marginal range ($AI < 0.7$). Because the desired and interfering transmitters have the same output power and both lie in the area of interest, there will be a region of points close to the interfering transmitter antenna at which the mobile receiver performance will be unacceptable ($S/I < 2$ dB; $AI \leq 0.44$). Propagation modeling is required to determine the size and shape of the “denied” region.

9.2.9 Remediation

There are several ways to remediate the problem:

- Increase the desired transmitter power. This may not be possible for practical, economic, or regulatory reasons. For example, it may degrade the performance of other systems in the environment. If increasing the desired transmitter power is possible, the action may shrink the denied region to an acceptable size.
- Employ a directional mobile antenna. Such an antenna would have to be steerable to ensure that it always pointed toward the desired antenna. However, there will be places where the mobile antenna cannot point toward the desired antenna without including the undesired antenna in the capture area. If the undesired antenna is directional and its pattern and orientation are known, it might be possible to operate in spite of being co-channel, but it would be difficult to perform the necessary geographic analysis. This action may shrink the denied region to an acceptable size.
- Select a channel that takes the interference out of the receiver passband. This is the most practical and effective solution. Since the adjacent channel rejection is 65 dB, the Handbook transfer functions show that the mobile receiver will then operate as required in most locations. Because of nonlinear (cosite) interactions, there is usually a small denied region that cannot be eliminated. The decision regarding the mobile antenna can then be based on other considerations.

9.3 RECEIVER PERFORMANCE ANALYSIS EXAMPLE 3

An analysis of Global Broadband Service (GBS) reception in the presence of a ground-based pulsed emitter is provided in this example. The GBS downlink is based upon the DVB-S2.

9.3.1 Background

DVB-S2 is an update of DVB-S. The update inserted new communications techniques which enable higher throughput, reduced end user equipment power and size burden, and improved satellite resource utilization.

DVB-S2 defines four modulation modes: QPSK, 8PSK, 16-ary Amplitude and Phase-Shift Keying (APSK) and 32-ary APSK. Underpinning DVB-S2 is the use of LDPC codes. DVB-S2 defines a wide range of allowable code rates: $1/4$, $1/3$, $2/5$, $1/2$, $3/5$, $2/3$, $3/4$, $4/5$, $5/6$, $8/9$, and $9/10$. An outer BCH code is defined in the standard, however, overall link performance is largely driven by the inner LDPC code. Note that the standalone LDPC code BER performance curve is so steep that an outer code provides very little performance improvement. The outer BCH code is primarily included in the standard to ensure the BER floor is very low.

9.3.2 Scenario Description

A notional satellite downlinks a DVB-S2 compatible signal to a notional ground-based receive terminal. Reception may be impaired due to the presence of a nearby ground-based pulsed emitter. While the ground-based pulsed emitter is off-tune, emissions still have the potential to degrade link BER performance or reduce link margin.

The DVB-S2 downlink is configured for QPSK modulation with LDPC rate 1/2 coding. The DVB-S2 signal data rate is 7.2 Mbps and the link C/N_0 is 88.6 dB-Hz in clear sky conditions. The C/N is 18.5 dB. The rain margin is 18.2 dB. The desired BER is 10^{-6} .

The pulsed interferer has a pulse duration of 1 μ sec and a PRF of 35 kHz. The pulsed interference characteristics can be stated in terms of the victim signal data rate as $T_p = 7.2/R_b$ and $PRI = 205.7/R_b$.

The geometry of the nearby pulsed emitter and the antenna orientation scenario are such that the C/I at the input to the victim receiver is -30 dB. An overwhelming majority of the interference power is well outside of the receive band of the desired signal and the FDR for this example scenario is 30 dB. An evaluation of the DVB-S2 receive terminal reveals that the interferer does not cause LNA compression.

In this example, the objective is to determine the reduction in rain margin due to the pulsed interferer.

9.3.3 Approach

A catalog look-up approach will form the basis of the analysis.

9.3.4 Analysis

The scenario description indicates that the victim signal uses QPSK modulation and rate 1/2 LDPC coding. Section 7.5.9 of this Handbook provides performance degradation curves for LDPC coding using QPSK modulation.

The scenario description notes that the interferer is off-tune with pulse characteristics of $T_p = 1 \mu$ sec and $PRI = 1/35000 = 28.6 \mu$ sec. These pulse characteristics can be stated in terms of the victim signal data rate as $T_p = 7.2 \cdot T_b$ and $PRI = 205.7 \cdot T_b$. Figures 7.5-25 and 7.5-26 of Section 7.5.9 provide QPSK LDPC performance degradation curves for off-tune pulsed interference. Examining Figures 7.5-25 and 7.5-26, it can be seen that neither interference scenario aligns very well with the interference scenario described in this example. Note, however, that the Figure 7.5-25 and 7.5-26 interference scenarios effectively bookend the interference scenario of this example, at least in terms of T_p and PRI . In this case, both performance degradation figures will be consulted and an interpolation will be performed.

Because this example involves a non-zero FDR, the data shown on Figures 7.5-25 and 7.5-26 cannot be directly used. All plots provided in this Handbook are referenced at the input to the receiver (where the receiver is defined to begin just after the antenna RF connector). The plots can, however, be stated based upon a reference point of carrier tracking loop input through knowledge of the FDR. Note that the figures in this handbook all state the relevant FDR. This allows the reference point of the curves to be translated from the receiver input to the carrier tracking loop input. This is accomplished by adding the FDR stated on Figures 7.5-25 and 7.5-26 (17.2 dB and 12.4 dB, respectively) to the C/I levels used to annotate the curves. The curves get re-annotated with the shifted C/I levels and the plots are now based upon a reference point at the carrier tracking loop input.

For this example, the C/I level at the carrier tracking loop input is 0 dB (i.e., C/I of -30 dB + 30 dB of FDR). Consulting Figures 7.5-25 and 7.5-26 (after they have been translated to the carrier

tracking loop input reference point), it can be seen that the off-tune pulsed interferer with limited pulses per code word cannot cause significant degradation to an LDPC-coded link.

9.3.5 Conclusion

The reduction in rain margin due to an undesired nearby ground-based pulsed emitter should be limited to approximately 0.2 dB. While this 0.2 dB estimate was obtained by interpolating between the data available in this Handbook (and may, therefore, carry moderate uncertainty), it is sufficient for this DVB-S2 link example. When interpolating between the data presented in this Handbook, the reader must decide whether risk can be accepted through the use of an estimated value or whether a specific simulation should be initiated to precisely characterize the potential impact of an interferer.

9.4 RECEIVER PERFORMANCE ANALYSIS EXAMPLE 4

The federal users in 1710-1855 MHz must vacate the 1710-1755 MHz portion of the band. There have been numerous analyses²⁷ on interference issues between systems in the 1710-1755 MHz portion of the band. In this example, however, we will not focus on the interference issues in the 1710-1755 MHz band, but instead present interference analysis between fixed and mobile systems in the 1755-1855 MHz band.

9.4.1 Background

The following is a list of major federal communications systems currently operating in the 1350-1855 MHz band which will continue to be operated in 1350-1710 MHz and 1755-1855 MHz bands.

- Fixed Service (FS) Systems
- Tactical Radio Relay Systems (TRR)
- Air-to-Ground Video Links
- Precision Guided Munitions
- Mobile Digital Radio Systems (MDRS)
- Air Combat Training Systems
- Satellite Control Networks (Space Ground Link System)
- Tactical Weapon Systems
- Other Systems (e.g., close combat communications, deployable emergency communications, etc.)

In this example, we will provide an analysis of interference between radio relay systems using AN/MRC-142 radios²⁸ and MDRS in the 1755-1855 MHz band (illustrated by a dashed ellipse in Figure 9.4-1). The RF analysis will:

- Model each system with selected radio parameters.

²⁷ DoD. *Investigation of the Technical Feasibility of Accommodating (IMT) 2000 in the 1755 – 1850 MHz Band.* 27 October 2000.

²⁸ <http://www.marcorsyscom.usmc.mil/sites/cins/CNS/Tactical%20Radios/DWTS.html>

- Perform a link budget analysis to calculate the required propagation path loss.
- Calculate the required separation distance for sharing between MDRS and TRR systems

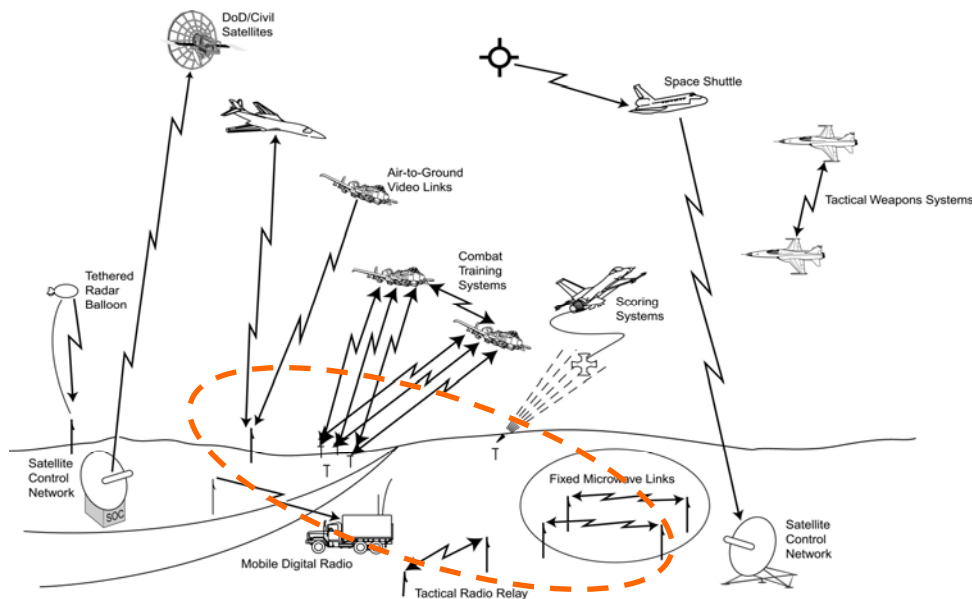

Figure 9.4-1. Pictorial Representation of Major Systems in the 1710-1850 MHz Frequency Band²⁹

9.4.2 Approach

The general technical approach is to predict undesired signal power at victim receivers by considering appropriate/applicable transmitter/receiver parameters, operational configurations and coupling between systems. The coupling between systems will depend on antenna orientations, propagation losses, and FDR. Analysis parameters that may vary include, but are not limited to, transmitter power, antenna gain, antenna pointing angles, antenna heights, data rates, receiver selectivities, and desired signal levels.

- Applicable propagation models to calculate path loss include terrain dependent models for fixed, known locations and SEMs for transportables and mobiles. Undesired received interference power levels and victim receiver interference thresholds are then used to assess the potential for interference and to calculate the required separation distance to prevent interference. The interference thresholds for the DoD tactical radio receivers are based on ITU Recommendation ITU-R F.1334, which limits the degradation due to interference in the FS receiver to 1 dB. This value corresponds to an allowed I/N of -6 dB.

9.4.3 Operating Environment

- Size: Maximum radius of desired link mobility is assumed to be 100 km
- Propagation environment: wide range of terrain based features

²⁹ U.S. Department of Commerce. National Telecommunications and Information Administration. Federal Operations in the 1755–1850 MHz Band: The Potential for Accommodating Third Generation Mobile Systems. Interim Report. 15 November 2000.

- Electromagnetic interference potential between TRR and MDRS systems in the 1350-1390 MHz and 1755-1855 MHz bands

9.4.4 Equipment Characteristics

The AN/MRC-142 can provide vehicle mounted stationary, wideband digital voice and data backbone radio relay service for a digital wideband transmission system.

The AN/MRC-142 (see Table 9.4-1) typically uses the frequency bands 1350-1390 MHz, 1432-1435 MHz, and 1710-1850 MHz, requires a 63-MHz minimum frequency separation between the site transmitter and receiver for a duplex link, has an LOS operational range of 35 miles and variants provide up to a 576 kbps LOS data path in the UHF range. The AN/MRC-142B is designed for ship to shore LOS communication and is complete with an RF amplifier and antenna.

Table 9.4-1. AN/MRC-142 Radio Parameters

Parameters	Value
Station Class	FX; Vehicle Mounted, stationary for use
TX Power	MRC-142A, 3 W; MRC-142B, 60 W; MRC-142C, 5 W
Tx Freq Band	1350-1850 MHz
Waveform; Modulation / Data Rate	610K0F7W; FSK / 576 kbps
Bandwidth	0.72 MHz
Tx/Rx Antenna Type / Pol / Height	Parabolic / Vertical Polarization / 30 m
Antenna Gain	20.3 dBi gain main beam; 6.3 dBi at 26-deg
Tx/Rx Beamwidth	11.2 deg
Rx Noise Figure	8 dB
Emission Bandwidth (MHz)	0.4 (-3 dB); 1.05 (-20 dB); 3.15 (-60 dB)
Receiver Bandwidth (MHz)	0.8 (-3 dB); 1.0 (-40 dB); 4.4 (-60 dB)
Receiver Sensitivity	-93 dBm @ BER=10 ⁻⁴
Receiver Noise Power	-107 dBm
Interfering Signal Threshold	-113 dBm

MDRS systems can provide mobile ad hoc and/or cellular based WLAN networks between mobile platforms. It is assumed notionally that the MDRS system is a component of a common user system that can support Mobile Subscriber Equipment systems that provide simultaneous voice, data, and video services.

We will assume that the notional MDRS may employ platform-based and Manpack/Handheld radios (see Table 9.4-2). The Ground Mobile Radio (GMR) Joint Tactical Radio System (JTRS) radio is assumed to employ the 4-channel Wideband Networking Waveform (WNW) whereas Manpack/Handheld JTRS radios employ the 2-channel Soldier Radio Waveform (SRW). Assumed RF parameters can be employed as part of notional interference analyses, since specific details are beyond the scope of this Handbook.

Table 9.4-2. Examples of JTRS Radios and Waveforms³⁰

JTRS Radio Examples	Waveform
Handheld, Man-pack, Small Form Fit (HMS): Support requirements for JTRS handheld and man-pack units/forms suitable for integration into platforms requiring a Small Form Fit radio	Handheld : SINGARS, EPLRS, SRW* (type-1 and type-2) Man-pack: SINGARS, EPLRS, HF, SRW* (type-1 and type-2), UHF SATCOM (DAMA)
Ground Mobile Radio (GMR): Support requirements for Army and USMC platforms	SINGARS, EPLRS, HF, UHF SATCOM (DAMA), SRW* (type-1) and SRW* (type-2)**, WNW*, ANW
Airborne, Maritime, Fixed Station (AMF): Support requirements for airborne, maritime, and fixed station platforms	WNW*, SRW*, LINK-16, UHF SATCOM, MUOS*

(*) New Waveforms; (**) For some applications

9.4.5 Link Budget Analysis

The interference analysis methodology between TRR and MDRS systems follows that of ITU-R F.1334.³¹ Interference analysis is performed to identify the required distance separation to protect the TRR receivers from the MDRS transmitters and the MDRS receivers from the TRR transmitters. This is achieved first by calculating the required propagation loss that corresponds to the interference threshold, and then using applicable propagation models to determine the required separation distance. It is assumed that there are two basic interference paths to consider:

- i. MDRS Mobiles (using assumed parameters for WNW or SRW waveform) interfere with the TRR receivers;
- ii. TRR transmitters (whose characteristics are shown in Table 9.4-1) interfere with the MDRS Base Station receivers

The above assessment can be used to evaluate the (co-channel and adjacent channel) separation distance requirements between TRR and MDRS systems. The analysis steps are as follows:

- Calculate received desired signal power
- Calculate received interference power
- Select receiver threshold based on the selected interference criteria (NTIA, ITU, etc.)
- Calculate minimum allowable path loss based on the selected interference criteria
- Select the most applicable propagation model based on terrain and mobility
- Calculate the required separation distance between TRR and MDRS systems
- Determine Interference Conflict Margin (ICM) within the separation distance

³⁰ Dr. Rich North. *Joint Tactical Radio System Connecting the GIG to the Tactical Edge Joint Program Executive Office Joint Tactical Radio System 23-25. October 2006.*

³¹ ITU-R F.1334 Recommendation. *Protection Criteria for Systems in the Fixed Service Sharing the Same Frequency Bands in the 1 to 3 GHz Range with the Land Mobile Services.*

9.4.5.1 Calculation of received desired signal power

The desired signal power S is calculated using Equation 2-1 as follows:

$$S = P_T + G_T + G_R - L_P - L_T - L_R$$

where

S	=	signal power at receiver LNA input, in dBm
P_T	=	signal power at power amplifier output, in dBm
G_T	=	transmitter antenna gain, in dBi
L_T	=	transmitter system losses (between amplifier and antenna), dB
G_R	=	receiver antenna gain, in dBi
L_P	=	propagation loss (between the transmitting antenna and receiving antenna), dB
L_R	=	receiver system losses (between antenna and LNA), dB

9.4.5.2 Calculation of received interference power

The interfering signal power level “ I ” is calculated, by including FDR into Equation 2-1, as follows:

$$I = P_{TI} + G_{TI}(\theta_T) + G_{RI}(\theta_R) - L_{PI} - L_{TI} - L_R - FDR$$

where

I	=	interfering signal power at the victim receiver (at receiver input), dBm
P_{TI}	=	transmitter power of the interfering signal source, dBm
$G_{TI}(\theta_T)$	=	antenna gain of the interfering transmitter in the direction of the victim receiving antenna (dBi);
$G_{RI}(\theta_R)$	=	antenna gain of the victim receiver in the direction of the interference source antenna (dBi);
θ_T	=	the off-axis angle between the boresight of the transmitting interfering antenna and the direction of the receiving victim station (degrees).
θ_R	=	the off-axis angle between the boresight of the victim receive antenna and the direction of the transmitting interfering station (degrees).
L_{PI}	=	propagation loss on the interfering signal path, dB
L_{TI}	=	interfering transmitter system losses, dB
L_R	=	victim receiver system losses, dB
FDR	=	frequency-dependent rejection (in dB) obtained by Equations 3-1 and 3-9.

9.4.5.3 Interference Thresholds

For each potential interference path, we calculate the desired signal level S at the input to the victim receiver, the victim receiver system noise power N referred to the receiver input, and the interfering signal power I at the same reference point (i.e., receiver input) of the victim receiver. These values are combined for comparison to interference thresholds expressed as I/N , S/I , and $S/(N+I)$ thresholds. Input data requirements for this analysis include the following parameters

- Operating frequency

- Transmit Power
- Transmit Antenna Gain
- Receive Antenna Gain
- Transmit and Receive Antenna Feedpoint Heights

9.4.5.4 Calculation of Separation Distance

An appropriate propagation model (see Table 2.4-1) based on the terrain is then used to determine the required distance separation corresponding to the required path loss for the given interference threshold level. Maintaining the required separation distance precludes interference between TRR and MDRS systems in the operational bands of interest (1350-1390 MHz or 1755-1850 MHz). The selected appropriate propagation model takes account of transmit and receive antenna heights, Fresnel zone, and terrain based effects.

9.4.5.5 Interference Conflict Margin

At any point within the separation distance, the ICM can also be calculated from

$$ICM_{I/N} = I/N - \text{Threshold}_{I/N}$$

9.4.6 Performance Analysis

There are several mitigation techniques (see Table 2.5-1) that could be explored to reduce the distance separation requirements and possibly allow band sharing. These include:

- Employ cross-polarization between DMRS base station receive antennas and the TRR transmit antennas as this can reduce the level of interference interactions.
- TRR :
 - i. Antenna relocation, shrouding, radiation fences,
 - ii. Sharing of operation scheduling,
 - iii. Limitations on geographical locations and operations.
- DMRS :
 - i. Selected antenna orientations,
 - ii. “Listen-before-transmit” capability,
 - iii. Dynamic, event-dependent frequency management.

9.5 RECEIVER PERFORMANCE ANALYSIS EXAMPLE 5

In this example, a hypothetical next generation X-band communications satellite system is being designed. The prospective system is similar to existing US Government communications satellite systems which operate in the 7250-8400 MHz band. Since other services are allocated for operation in the 7250-8400 MHz frequency band, the satellite system and its user terminals must be capable of operating in the presence of interference from other services.

Only the X-band communications satellite downlink signal structure is considered in this example. The downlink uses the 7250-7750 frequency band. Two competing signal structures are evaluated and the maximum data rate in the presence of interference is computed. One signal structure is based upon conventional concatenated coding (RS concatenated to convolutional) and the other signal structure is based upon a more modern coding approach, a TPC.

9.5.1 Background

The 7250 to 7750 MHz frequency band is used for various purposes including communications satellite downlinks and fixed point-to-point microwave links. Many of the users of this frequency band are Federal entities including the DoD.

9.5.2 Scenario Description

A hypothetical X-band satellite downlinks to a notional ground-based receive terminal. In clear sky conditions and in the presence of no interference, the X-band satellite downlink C/N_0 is 83 dB-Hz. The uplink C/N_0 does not effect the overall link C/N_0 because the hypothetical X-band satellite demodulates the data onboard and remodulates for transmission to the user terminal.

A Frequency Division Multiplexing (FDM) channelization approach is used on the downlink such that the 7250-7750 MHz frequency band is divided into many 20 MHz channels. The downlink modulation can be BPSK, QPSK, OQPSK, 8PSK and 16QAM, depending upon the loading of the X-band satellite. The ground-based user receive terminals automatically identify the modulation technique based upon ambiguity resolution techniques.

To minimize on-orbit hardware requirements, a single downlink coding technique will be supported. Two coding approaches are under consideration, a (255,223) RS code concatenated with a rate $\frac{1}{2}$ convolutional code and $(128,120)^2$ TPC coding. The primary advantage of the concatenated code is the tremendous legacy of successful use in communications systems. The primary drawback of the concatenated code is the tremendous bandwidth expansion introduced by the $(\frac{1}{2}) \times (223/255)$ code rate. The advantage of the TPC code is that it is a rate $\frac{7}{8}$ code with a coding gain better than that of a standalone rate $\frac{1}{2}$ convolutional code.

The ground-based user terminals must be capable of receiving the downlink signal in the proximity of terrestrial services authorized for operation in the same frequency band. Since the ground-based user terminals are specified to operate down to an elevation angle of 5° , there is a potential for significant interference from terrestrial systems.

The overall downlink BER must be 10^{-8} or better following decoding.

Of particular concern to the system designers is the possibility that fixed radio relay transmitters will operate within close proximity to the X-band satellite user terminals. Based upon consideration of likely interference scenarios, the user terminals must meet all performance requirements with a worst

case C/I of 10 dB. This C/I is referenced at the input to the user terminal demodulator and may be AWGN-like interference, CW-like interference or something in between.

9.5.3 Approach

A catalog look-up approach will form the basis of the analysis.

9.5.4 Analysis

The scenario description indicates the X-band downlink signal modulation may be BPSK, QPSK, OQPSK, 8PSK and 16QAM. Section 6 of the Handbook provides numerous performance degradation curves for each of these modulation techniques. While these curves are useful, they are not directly applicable to this example because this example includes coding and the performance degradation data in Section 6 are for the uncoded scenario.

The scenario description also states that concatenated coding and TPC coding are being considered. We can see that Figures 7.5-11 through 7.5-18 provide performance degradation curves for QPSK with $(64,57)^2$ TPC coding and Figures 7.9-2 through 7.9-9 provide performance degradation curves for QPSK with concatenated $(255,223)$ RS + rate $\frac{1}{2}$ convolutional coding.

Since the interferer is not a pulsed interferer, we can further downselect the applicable performance degradation data to be Figures 7.5-11, 7.5-12, 7.9-2, and 7.9-3. While Figures 7.5-11 and 7.5-12 are applicable to a $(64,57)^2$ TPC code and this example involves a $(128,120)^2$ TPC code, the overall code rates are very similar and we would expect the $(128,120)^2$ TPC code to perform similar to the $(64,57)^2$ TPC code in an interference environment.

The scenario description provides no information regarding the specifics of the radio relay interference other than the interference may be anything between CW-like and AWGN-like. The scenario description states that the minimum C/I which must be considered is 10 dB and that the 10 dB is after FDR has been considered (i.e., at the input to the demodulator).

Consulting Figures 7.5-11, 7.5-12, 7.9-2, and 7.9-3, we can see that the performance degradation curves are referenced to the input to the victim receiver. Looking closer, however, we see that the FDR applicable for the collection of the performance degradation data is 0 dB, i.e., the curves were generated by placing all of the interference power directly within the RF/IF channel passband. For this reason, the curves are applicable as-is for a reference point of the receiver input and a reference point of the demodulator input.

The scenario description states that the required BER performance is 10^{-8} or better. Unfortunately, the performance degradation data of this Handbook does not go down to a BER of 10^{-8} , therefore, we must extrapolate. Consulting Figures 7.5-11, 7.5-12, 7.9-2, and 7.9-3 and using required E_b/N_0 as our metric, we can see that the concatenated coding approach outperforms the TPC code when the interference is CW-like, however, the concatenated coding approach under performs the TPC code when the interference is AWGN-like. Similar performance trends would be expected for the other modulation techniques identified in this example.

9.5.5 Conclusions

Given that the downlink C/N_0 is 83 dB-Hz and the maximum available channel bandwidth is 20 MHz, it is clear that the satellite downlink is spectrum limited and not power-limited, i.e., the 83 dB-Hz downlink C/N_0 is more than sufficient to accommodate data rates as large as about 35

Mbps. Considering that the concatenated code dramatically expands the downlink signal bandwidth and does not significantly outperform the TPC code in an interference channel, a strong argument can be made for recommending the TPC code.

It is noteworthy that many factors need to be considered beyond the few considered in this hypothetical example. Such factors may include signal processing latency, performance improvement techniques (e.g., interleaving), risk, weight, cost, etc.

SECTION 10 - REFERENCES

- [1] Department of Commerce. *Spectrum Policy for the 21st Century – The President’s Spectrum Policy Initiative: Report 1, Report 2*. June 2004.
- [2] Department of Commerce. *White House Executive Memorandum, Subject: Improving Spectrum Management for the 21st Century*. 23 November 2004. *The latest released document for this subject is Spectrum Management for the 21st Century – Plan to Implement Recommendations of the President’s Spectrum Policy Initiative*. March 2006.
- [3] H. T. Friis. *A Note on a Simple Transmission Formula, Proc. IRE*. pp. 254-256. May 1946.
- [4] NASA JPL. *Link Analysis of a Telecommunication System on Earth, in Geostationary Orbit, and at the Moon: Atmospheric Attenuation and Noise Temperature Effects*. Interplanetary Network Progress Report 42-168. 15 February 2007.
- [5] ITU-R Recommendations: S.733-2 and P.372-8.
- [6] ITU-R Recommendation SM.337-6.
- [7] Theodore S. Rappaport. *Wireless Communications Principles and Practice*. 2nd ed., Prentice Hall. 2002.
- [8] John G. Proakis. *Digital Communications*. 3rd Ed., McGraw-Hill Series in Electrical Engineering. 1995.
- [9] American National Standards Institute. *Methods for Calculating AI, Octave Band Values, and Preferred Frequencies*. ANSI S3.5-1969 R. 1986.
- [10] Journal of the Acoustical Society of America. *Derivation of Primary Parameters and Procedures for Use in Speech Intelligibility Predictions*. Vol. 82:413-422. 1987.
- [11] Journal of the Acoustical Society of America. *Methods for the Calculation and Use of Articulation Index*. Vol. 34, 1698–1702. 1962.
- [12] Sentagi S. Utami. *An Acoustical Analysis of Domes*. Brigham Young University. August 2005.
- [13] H. Taub and D. L. Schilling. *Principals of Communication Systems*. McGraw-Hill. 1971.
- [14] V. K. Prabhu and L. H. Enloe. *Interchannel Interference Considerations in Angle Modulated Systems*. Bell System Technical Journal 48, No. 7. pp. 2333-2358. September 1969.
- [15] William C. Jakes. *Microwave Mobile Communications*. IEEE Press. 1993.
- [16] Asrar U. H. Sheikh. *Wireless Mobile Communications: Theory and Techniques*. Kluwer Academic Publishers. 2003.
- [17] H. Fine. *A Further Analysis of TASO Panel 6 Data on Signal-to-Interference Ratios and Their Application to Description of Television Service*. T.R.R. Report No. 5.1.2. Washington, DC: FCC. 1 April 1960.
- [18] Shu Lin and Daniel Costello. *Error Control Coding: Fundamentals and Applications* Prentice-Hall, Inc. 1983.
- [19] S. Lin, D. Costello. *Error Control Coding*. Prentice Hall, 2nd Ed. 2004.

- [20] C. Berrou, A. Glavieux, P. Thitimajshima. *Near-Shannon Limit Error – Correcting Coding and Decoding: Turbo Codes*. ICC, pp 1064-1070. 1993.
- [21] Charan Langton. *Turbo Decoding Using the MAP Algorithm Part 2*. Intuitive Guide to Principles of Communications. 2006.
- [22] M. Luby. *LT Codes*. Proceeding of Foundations of Computer Science. 2002.
- [23] Ashish Khisti. *Tornado Codes and Luby Transform Codes*. 22 October 2003.
- [24] L. Rabiner and R. Schaefer. *Digital Processing of Speech Signals*. Prentice-Hall, Inc., Englewood Cliffs, NJ. 1978.
- [25] N. Jayant and P. Noll. *Digital Coding of Waveforms*. Prentice-Hall, Inc., Englewood Cliffs, NJ. 1984.
- [26] E. Harras and J. Preusse. *Communication Performance of CVSD at 16/32 Kilobits/second, Communications-Electronics System Integration Office*. US Army Electronics Command, Fort Monmouth, NJ. 1974.
- [27] DoD. *Investigation of the Technical Feasibility of Accommodating (IMT) 2000 in the 1755 – 1850 MHz Band*. 27 October 2000.
- [28] <http://www.marcorsyscom.usmc.mil/sites/cins/CNS/Tactical%20Radios/DWTS.html>
- [29] U.S. Department of Commerce National Telecommunications and Information Administration. *Federal Operations in the 1755 – 1850 MHz Band: The Potential for Accommodating Third Generation Mobile Systems*. Interim Report. 15 November 2000.
- [30] Dr. Rich North. *Joint Tactical Radio System Connecting the GIG to the Tactical Edge*. Joint Program Executive Office Joint Tactical Radio System. 23-25 October 2006.
- [31] ITU-R F.1334 Recommendation. *Protection Criteria for Systems in the Fixed Service Sharing the Same Frequency Bands in the 1 to 3 GHz Range with the Land Mobile Services*.
- [32] Matti Latva-aho. *Ultra Wideband Technologies*. October 2005.
- [33] FCC. *Revision of Part 15 of the Commission's Rules Regarding Ultra-Wideband Transmission Systems*. First Report and Order, FCC-02-48. 14 February 2002.
- [34] DISA. *An Overview of MIMO Technology: Its Potential Role in a DSA-enabled Network*. DISA Technology Tracking Report. March 2008.

APPENDIX A - INTERFERENCE THRESHOLD TABLE

Radio Service (Victim Receiver)	Single-Entry Interference Criterion	Justification for Interference Criterion
Land Mobile	I/N = -6 dB	Criterion for digital systems corresponding to a 1-dB increase in the receiver noise level.
	I/N = 0 dB	Criterion for analog systems, assuming that a minimum desired signal level would be sufficiently greater than the noise level to preclude degradation from interference at the noise level.
Mobile	I/N = -6 dB	Criterion for digital systems, corresponding to a 1-dB increase in the receiver noise level.
	I/N = 0 dB	Criterion for analog systems, assuming that a minimum desired signal level would be sufficiently greater than the noise level to preclude degradation from interference at the noise level.
Aeronautical Mobile	I/N = -6 dB	Criterion for digital systems, corresponding to a 1-dB increase in the receiver noise level.
	I/N = 0 dB	Criterion for analog systems, assuming that a minimum desired signal level would be sufficiently greater than the noise level to preclude degradation from interference at the noise level.
Maritime Mobile	I/N = -6 dB	Criterion for digital systems corresponding to a 1-dB increase in the receiver noise level.
	I/N = 0 dB	Criterion for analog systems, assuming that a minimum desired signal level would be sufficiently greater than the noise level to preclude degradation from interference at the noise level.
Fixed	I/N = -9 dB	The interference power is 13% of the noise power and is used in many analyses as a first level criterion for analog (FDM/FM) systems.
	I/N = -6 dB ^a	Performance degradation criterion for digital systems is a decrease in the BER from 10^{-6} to 10^{-5} (a change in the order of magnitude) which corresponds approximately to a 1-dB increase in the receiver noise level.
	I/N = 0 dB	Interference criterion for fixed and transportable radar systems to digital radio-relay systems.
	I/N = 10 dB	Interference criterion for maritime and land mobile radar systems to digital radio-relay systems.
Radiolocation	I/N = -10 dB ^b	Criterion for basic search radar with pulsed interference (duty cycle > 10%) and noise like interference.
	I/N = -6 dB ^b	Corresponds to a 1-dB increase in the receiver noise of a search/track radar.
	I/N = -3 dB ^b	Corresponds to a 10% range reduction of a search/track radar.
	I/N = 0 dB ^b	Criterion for basic search radar with pulsed interference (duty cycle < 10%)
	I/N = 10 dB ^b	Based on a low probability of observation on display of false detection.
Radionavigation	I/N = 9 dB ^b	Criterion for radar-to-radar interactions based on a probability of detection of 0.1 and a probability of false alarm of 10^{-8} at the radar receiver.
Aeronautical Radionavigation	I/N = -6 dB	Criterion corresponds to a 1-dB increase in the receiver noise level.
Maritime Radionavigation	I/N = -6 dB	Criterion corresponds to a 1-dB increase in the receiver noise level.
Meteorological Satellite	I/N = -10 dB	The criterion for adequate protection of Geostationary Operational Environmental Satellite Command and Data Acquisition stations.
	I/N = -4.8 dB	Criterion corresponds to a 1.25 dB reduction in performance.

Radio Service (Victim Receiver)	Single-Entry Interference Criterion	Justification for Interference Criterion
Maritime Mobile Satellite	I/N = -12.2 dB	Criterion based on an effective system temperature increase of 6%
Mobile Satellite	I/N = -12.2 dB	
Aeronautical Mobile Satellite	I/N = -12.2 dB	
Land Mobile Satellite	I/N = -12.2 dB	
Fixed Satellite	I/N = -12.2 dB	
Radionavigation Satellite	I/N = -12.2 dB	
Earth Exploration Satellite	I/N = -4.8 dB	Criterion corresponds to a 1.25 dB reduction in performance.
Meteorological Aids	I/N = 5 dB	This value is based on a maximum permissible interference level necessary to protect radiosonde receivers in the 400.15-406 MHz frequency band.
	I/N = 8 dB	This value is based on a maximum permissible interference level necessary to protect radiosonde receivers in the 1668.4-1700 MHz frequency band.
Meteorological Aids (Radar)	I/N = -10 dB	Criterion is based on high duty cycle (>10%) pulsed or FM-CW interference to the wind profiler radar.
	I/N = 50 dB	Criterion is based on low duty cycle (< 1%) pulsed interference to the wind profiler radar.
Broadcasting	I/N = -10 dB	Conservative criterion for a first level interference analysis.
Space Research	I/N = -6 dB	Criterion developed for near earth space research.
	I/N = 2.3 dB	Criterion for deep space earth stations, based on a 10° increase in the static phase error.
Radio Astronomy (Passive)	I/N = -60 dB ^c	Criterion developed for radio astronomy continuum observations.
	I/N = -48 dB ^c	Criterion developed for radio astronomy spectral line observations.
Space Operation	I/N = -2 dB	Criterion developed from the Communications/Electronics Receiver Degradation Handbook ESD-TR-75-013.
<p>NOTES:</p> <p>^a Does not include the effects of error correction coding.</p> <p>^b The interference criterion will be significantly different, depending on whether the interference is pulsed or CW.</p> <p>^c The interference criterion is based on a maximum value of interference computed, assuming a 0-dBi sidelobe antenna gain.</p>		

APPENDIX B - WIRELESS SYSTEMS SUPPLEMENT

B.1. STANDARDS BASED WIRELESS NETWORKS

The emergence of new wireless technologies is motivated by the ever-increasing demand for capacity and higher data rates. Increasingly, broadband wireless access to the Internet and wireless data connectivity to mobile users are becoming the driving force behind future growth in the telecommunications industry. Supported by timely updates in the 802.11/WiFi standards and by affordable prices, WLAN equipment has rapidly penetrated the marketplace. Metropolitan area networks supported by the newly established 802.16/WiMax standards are being deployed increasingly for both military and commercial applications. Hybrid approaches utilizing WiMax, mesh networks, and WLAN are also being designed and deployed.

B.2. MOBILE WIRELESS SYSTEMS

Mobile wireless systems have evolved from analog voice into 2G/3G and 4G voice and high speed data systems. International Mobile Telecommunications-2000 (IMT-2000) is the global standard for the 3G mobile wireless systems. The two most widely deployed 3G networks are based on either Wideband Code Division Multiple Access (W-CDMA) or CDMA2000 standards as defined by the ITU. Mobile systems require that the antennas not be constrained to favor one fixed direction over another. This can be accomplished very simply by utilizing omnidirectional antennas. Alternatively, smart antennas can be used to adapt to changes in the direction of propagation.

B.3. P25 LMR PUBLIC SAFETY WIRELESS SYSTEMS

Project 25 (P25) was first established in 1989 to address the need for common digital public safety radio communications standards for First Responders and Homeland Security/Emergency Response professionals. P25 standards apply to Land Mobile Radio (LMR) equipment authorized or licensed, in the US. However, it has been deployed globally. Member organizations include:

- Association of Public Safety Communications Officials
- The National Association of State Telecommunications Directors
- NTIA
- National Communications Systems
- DoD

Key P25 technology benefits are summarized as follows:

- Interoperability: Different agencies can communicate directly with each other.
- Multiple Vendors: Competing interoperable products from multiple vendors
- Backwards Compatibility: Radios can communicate in analog mode with analog radios, and either digital or analog mode with P25 radios.
- Encryption Capability: Protects digital communications (voice and data)
- Spectrum Efficiency: Maximizes spectrum efficiency by narrowing bandwidths.
- Improved QoS: 2.8 kbps of 9.6 kbps channel capacity is allocated for FEC.
- Enhanced Functionality: 2.4 kbps of 9.6 kbps channel capacity is used for signaling and control.

The frequency bands utilized for P25 are VHF/UHF, 700/800 MHz and 4.9 GHz. The P25 narrowband mandate for spectrum efficiency issued by NTIA requires that federal LMR systems operating at VHF and UHF be narrow-banded (12.5 kHz channel bandwidth).

- **VHF and UHF:** Primarily voice and low speed data. 150-512 MHz channel are required to reduce from 25 kHz to 12.5 kHz bandwidth by January 2013
 - VHF-Low: 25 MHz to 50 MHz
 - VHF-High: 138 MHz to 174 MHz
 - UHF: 408 MHz to 512 MHz
- **700/800 MHz:** Shared voice and data; mostly in metro areas
 - **700 Band:** 24 MHz of dedicated bandwidth; supports mobile broadband data
 - **800 Band:** Still 25 kHz (wideband)
- **4.9 GHz:** Broadband (multimedia) applications, used for short range.

P25 Key Technical Characteristics and Phased Implementations:

Phase 1:

- Operates in Frequency Division Multiple Access (FDMA) mode, using 2.5 kHz analog, digital, or mixed mode channels.
- Employs constant amplitude Continuous 4 level FM (C4FM) modulator, which is comprised of a Nyquist Raised Cosine Filter, a shaping filter, and an FM modulator (see Figure B3-1). C4FM modulation is similar to differential QPSK where each symbol is shifted in phase by 45 degrees from the previous symbol.
- Receivers designed per the C4FM standard can also demodulate the "Compatible Quadrature Phase Shift Keying" (CQPSK) standard, where deviation at symbol time is the same as C4FM while using only 6.25 kHz of bandwidth.
- Vocoding employed is Improved Multi-Band Excitation for digital representation of speech using a bandwidth of only 4.4 kHz.

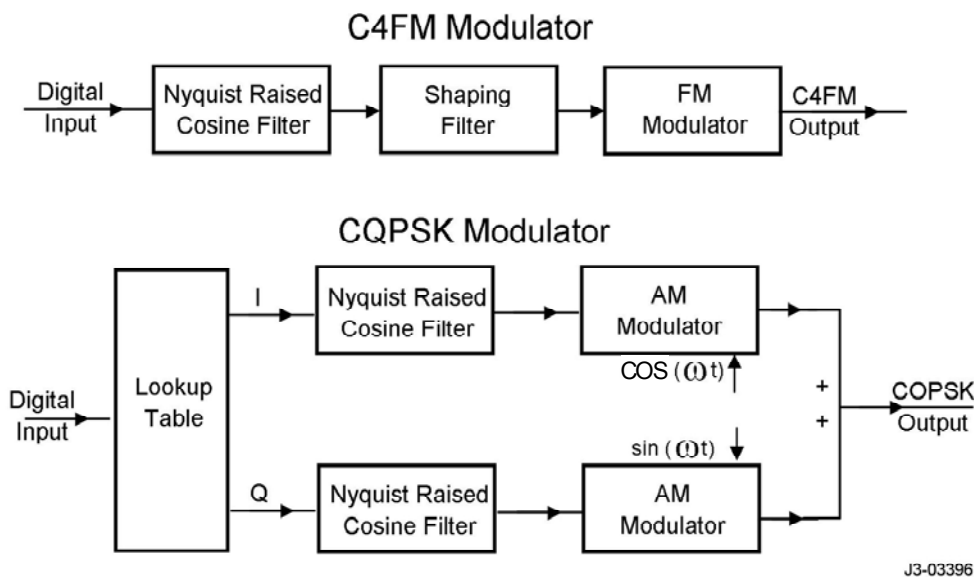

J3-03396

Figure B.3-1. P25 C4FM and CQPSK Modulators

Phase 2:

- In the FDMA solution, digital information is transmitted over a 6.25 kHz channel using the CQPSK modulation format.
- CQPSK modulates the phase and simultaneously modulates the carrier amplitude to minimize the width of the emitted spectrum which generates an amplitude modulated waveform. The modulation sends 4800 symbols/sec (as also shown in Table B.3-1, each symbol conveys 2 bits of information)
- In addition to FDMA, Phase 2 P25 systems also operate in TDMA over a 6.25 kHz channel, two slots in a 12.5 kHz channel, resulting in one voice channel or a minimum 4800 bps data channel per 6.25 kHz bandwidth.
- Vocoding employed is Advanced Multi-Band Excitation for digital representation of speech using a bandwidth of only 4.8 kbps

Table B.3-1. Mapping Between Symbols and Bits in P25 C4FM and CQPSK

Information Bits	Symbol	C4FM Deviation (Phase 1)	CQPSK Phase Change (Phase 2)
01	+3	+1.8 kHz	+135 degrees
00	+1	+0.6 kHz	+45 degrees
10	-1	-0.6 kHz	-45 degrees
11	-3	-1.8 kHz	-135 degrees

As illustrated in Figure B.3-1, The CQPSK modulator is comprised of In Phase (I) and Quadrature Phase (Q) amplitude modulators that modulate two carriers, where Q phase is delayed from the I phase by 90 degrees. The QPSK demodulator receives a signal from either the C4FM modulator or the CQPSK modulator. Using an FM detector in the first stage of the demodulator, the common receiver is allowed to receive analog FM as well as C4FM and CQPSK.

Phase 3:

In this phase, P25 systems address the need for high-speed data in wide area, multiple-agency networks. The European Telecommunications Standards Institute and Telecommunications Industry Association are working collaboratively on the Mobility for Emergency and Safety project.

The Handbook performance curves related to FM and QPSK, can be applied for P25 systems analysis, and the propagation models applicable to VHF/UHF, 700/800 MHz, and 4.9 GHz can be used to calculate the coverage range for the system under study.

B.4. ULTRA-WIDEBAND SYSTEMS

In February 14, 2002 the FCC adopted the First Report and Order that permits the marketing and operation of certain types of Ultra-Wideband (UWB) products. The Full report was released April 22, 2002. However, regulatory efforts by the ITU are being conducted by ITU-R TG 1/8 for global UWB recommendations. ITU-R SM.1757 presents a guidance summary of studies related to the impact of devices using UWB technology on radio communication services. The FCC revised definition³² for UWB is any device where the fractional bandwidth (measured at the -10 dB points)

³² Matti Latva-aho. *Ultra Wideband Technologies*. October 2005.

is greater than 0.25 or (for systems with a center frequency > 6 GHz) occupies 1.5 GHz or more of spectrum.

The fractional bandwidth is based on the frequency limits of the emission bandwidth using the formula: $(f_H - f_L)/f_c$, as shown in Figure B.4-1 below. Narrowband (NB) is commonly defined as $(f_H - f_L)/f_c < 1\%$.

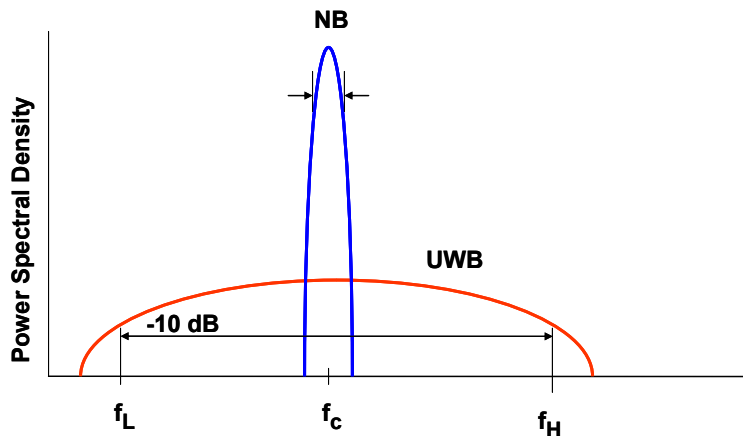

Figure B.4-1. Illustration of UWB Fractional Bandwidth

UWB technology is based on the generation of very short pulses of RF energy, similar to a radar pulse, giving rise to spectral components covering a very wide bandwidth in the frequency domain. UWB communications coexist with other NB wireless networks. Since UWB signals occupy such a large bandwidth, they operate as an overlay system with existing NB radio systems such as GPS, Cellular/Personal Communications Service Networks, Internet Service Manager and Unlicensed National Information Infrastructure band WLAN, etc.

UWB technology offers some key advantages when applied to communications. First, UWB technology enables co-existence with existing NB and wideband radio services. It also enables communications at high data rates with low S/N. In addition, UWB operates with a high bandwidth which helps achieve more resolvable multipath performance and greater frequency diversity. Communications utilizing UWB are jam-resistant with a low probability of intercept/detection. Finally, UWB technology is able to achieve this level of performance while maintaining a relatively low power spectral density and can be developed using simple chip hardware architecture.

Historically, UWB has been used for applications such as ground-penetrating radar, vehicle proximity detection, radar, and device tracking. However, UWB technology can also be effectively applied to data communications. In fact, UWB technology operating in the frequency band between 3.1-10.6 GHz, has been endorsed³³ by the FCC for communications applications. Key UWB transmission technologies are summarized as follows:

1. Impulsive Radio (IR)-UWB
2. Direct Sequence (DS)-UWB

³³ FCC. *Revision of Part 15 of the Commission's Rules Regarding Ultra-Wideband Transmission Systems. First Report and Order, FCC-02-48. 14 February 2002.*

3. Multiband Orthogonal Frequency Division Multiplexing (MB-OFDM) UWB

4. Fast Frequency Chirps (Chirp-UWB)

IR-UWB is based on transmitting extremely short pulses (0.2 ns ~ 1.5 ns) on a very low duty cycle (on the order 1/100, 1/1000, or less) using low power pulses that have a very wide spectrum. In this single-band implementation, one pulse instantaneously occupies the UWB bandwidth. Modulations employed include OOK, Pulse Amplitude Modulation, PPM, PSK and BPSK modulation.

DS-UWB is similar to conventional DS Spread Spectrum/W-CDMA carrier based radios. A PN sequence is multiplied by an impulse sequence at a duty cycles approaching a sinusoidal carrier. The chipping rate is some fraction, $1/N$, of the center frequency. The DS-UWB uses shaped non-sinusoidal wavelets to occupy the desired spectrum in an efficient manner and Multi-level Bi-Orthogonal Keying modulation in combination with QPSK depending on the required data rate.

For **MB-OFDM UWB** the UWB frequency band is divided into several smaller bands. Each of these bands has a bandwidth greater than 500 MHz, to comply with the FCC definition of UWB. It has been proposed that the 3.1 to 10.6 GHz spectrum is divided up into 14 contiguous 528 MHz bands. MB-OFDM "hops" a 528 MHz wide OFDM signal (128 carriers spaced 4.125 MHz apart using QPSK modulation) between several bands. For co-existence with other radio systems and interference mitigation, it is proposed that transmissions in bands and tones (i.e., OFDM carriers) could be independently controlled (e.g., occurrence, power level).

Sweeping a carrier across a wide RF range can be achieved by simple RF components and a single matched filter can cope with a wide range of Doppler shifts. However, the cost factor for implementing Chirp UWB is not low for the very wide bands employed by UWB.

B.5. COGNITIVE NETWORKS

Modern radio communications networks often operate in environments where resources, application data, and user behaviors vary in time. User behaviors are linked to user mobility and user request patterns. All these parameters vary as a function of time. Cognitive Networks (CNs) are capable of perceiving current network conditions and then planning, learning, and acting according to end-to-end goals. CRs are the component nodes of CNs and provide the necessary end-user intelligence. CRs help enable Dynamic Spectrum Access for better spectrum efficiency. A CN is able to establish links between its CR nodes to provide connectivity and adapts to changes in environment, topology, operating conditions and user requirements.

CNs exhibit several key features. CNs have automated network management characteristics. Another key feature of CNs is the capability to allow cognition to be performed collectively within the network by leveraging the sensory information gathered by each of the CRs within the network. CNs are also able to perform collective reasoning to achieve end-to-end network goals. This reasoning could include functions such as reconfiguration of CRs based on collective decisions. A key feature that enables this reasoning process is the CRs ability to learn from past actions. This learned behavior is another factor that differentiates cognitive networks from other types of radio networks.

B.6. MULTI-INPUT MULTI-OUTPUT

MIMO is a subset of smart antenna (SA) technology experiencing increasing interest. As an extension of SA technology, MIMO leverages spatial diversity as a means to improve the overall reliability and performance of band-limited systems.³⁴ This is accomplished through the use of multiple antennas at both the transmitter and receiver providing an overall improvement in communication performance. MIMO schemes can be categorized into single-user MIMO (SU-MIMO) schemes and multi-user MIMO (MU-MIMO) schemes. SU-MIMO is a point-to-point communication and a single transmitter and receiver are assumed. MU-MIMO can be considered for point-to-multi-point and multi-point-to-point channel environments.

MIMO technology offers significant increases in data throughput and link range without additional bandwidth or transmit power. These independent spatial signatures can be used in several ways. The spatial signatures can be exploited to provide redundancy of the transmitted data thus improving the reliability of transmission. These spatial signatures can also be exploited to increase the number of data streams thereby increasing the data rate of the system. The multiple spatial signatures can also be used for combating interference in the system.

Multiple antennas at both ends of a wireless and digital beamforming/signal processing system provide significant improvements in terms of system spectral efficiency and link reliability. This efficiency is achieved through the use of multiple antennas on the receiver to provide improved S/N and increased coverage/range. In addition, spatial diversity helps mitigate fading which results in improved link QoS. Finally, spectral efficiency is improved by using spatial multiplexing and beamforming which mitigate interference resulting in improved link capacity and performance.

Receiver design becomes very complex when implementing spatial multiplexing techniques. MIMO systems using spatial multiplexing are typically combined with OFDM or with Orthogonal Frequency Division Multiple Access modulation. Both techniques efficiently handle the problems created by a multi-path channel. Commercial wireless applications with OFDM and MIMO together were shown to significantly increase channel capacity compared to those with OFDM alone. The use of MIMO in various types of wireless networks, including commercial and military applications of WLAN / 802.11, WiMax / 802.16e provides a significant increase in data rate.

³⁴ DISA. *An Overview of MIMO Technology: Its Potential Role in a DSA-enabled Network. DISA Technology Tracking Report. March 2008*

DISTRIBUTION LIST

External	No. of Copies (.pdf)
National Telecommunications and Information Administration Chief, Spectrum Engineering and Analysis Division 1401 Constitution Avenue N.W., Room 6725 Washington, DC 20230	1
Office of the Assistant Secretary of Defense (NII)..... Director, Spectrum Programs and Policy Office 6000 Defense Pentagon Washington, DC 20301-6000	1
Navy and Marine Corps Spectrum Center Suite 1202 2461 Eisenhower Avenue Alexandria, VA 22331	1
Air Force Frequency Management Agency Suite 1203 2461 Eisenhower Avenue Alexandria, VA 22331	1
Army Spectrum Management Office..... Suite 1204 2461 Eisenhower Avenue Alexandria, VA 22331	1
 Internal	
DSO / R. DeSalvo.....	1
DSO/SPO / S. Molina.....	1
DSO/SPO / D. O'Neill.....	1
DSO/JSC / M. Williams.....	1
DSO/JSC / R. Schneider.....	1
DSO/JSC / A. Fitch.....	1
DSO/JSC / P. Mager.....	1
DSO/JSC / T. Grove.....	1
DSO/JSC / R. Lynch.....	1
DSO/JSC/ H. McDonald.....	1
ITT/AES / J. Wesdock.....	1
ITT/AES / T. Trusner.....	1
ITT/AES / F. Koziuk.....	1
ITT/AES / R. LaFontaine.....	1
ITT/AES / C. Patel.....	1
ITT/AES / E. Bustamante.....	1
ITT/AES / G. Michel.....	1
ITT/AES / Y. Zhang.....	1
ITT/AES / D. McLemore.....	1

This page intentionally left blank.